

J. BACHELDER.
Machine for Cutting Bungs.

No. 164,251.

Patented June 8, 1875.

Fig. 1.

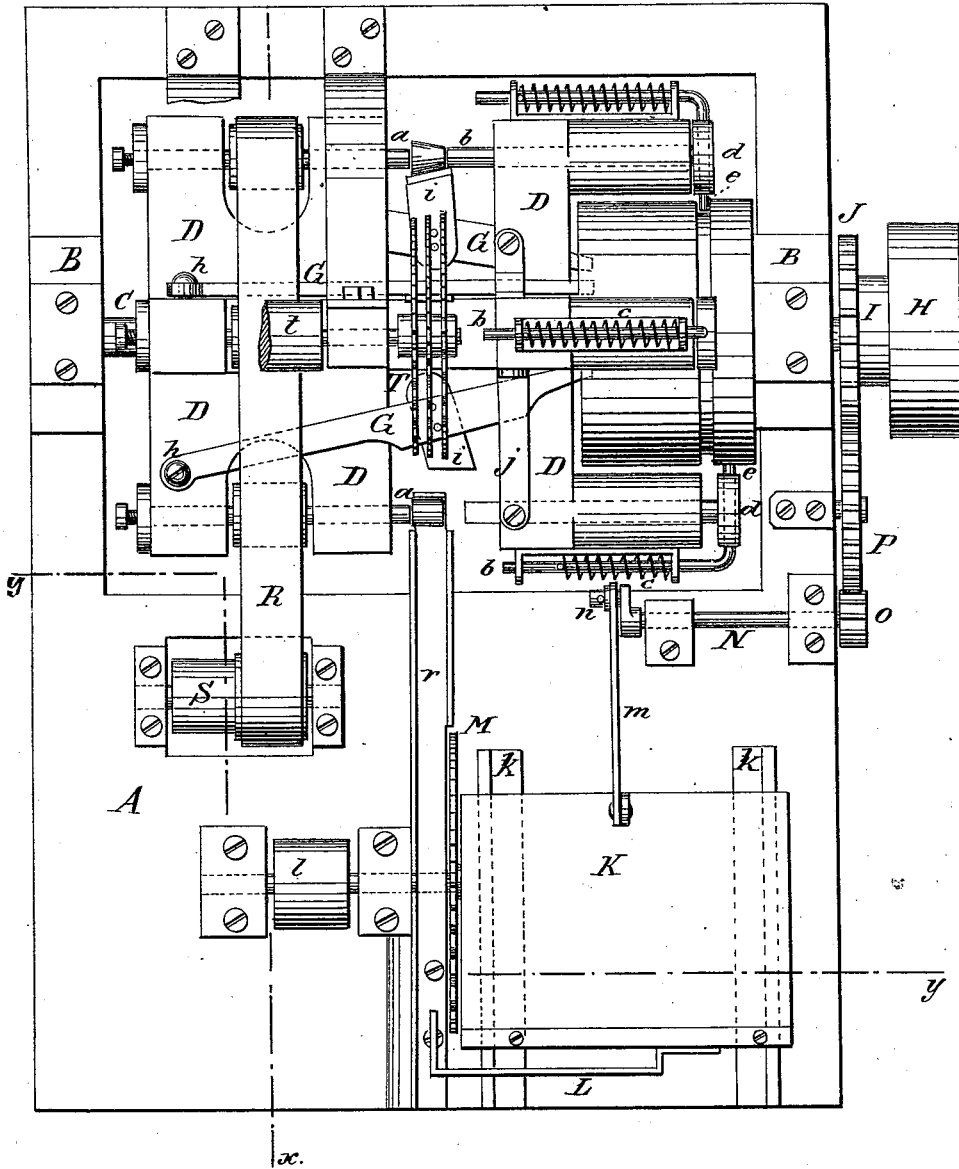

Witnesses:
W. J. Lovell
H. K. Mattenber

Inventor:
 John Bachelder
 per
[Signature]
att

J. BACHELDER.
Machine for Cutting Bungs.

No. 164,251.

Patented June 8, 1875.

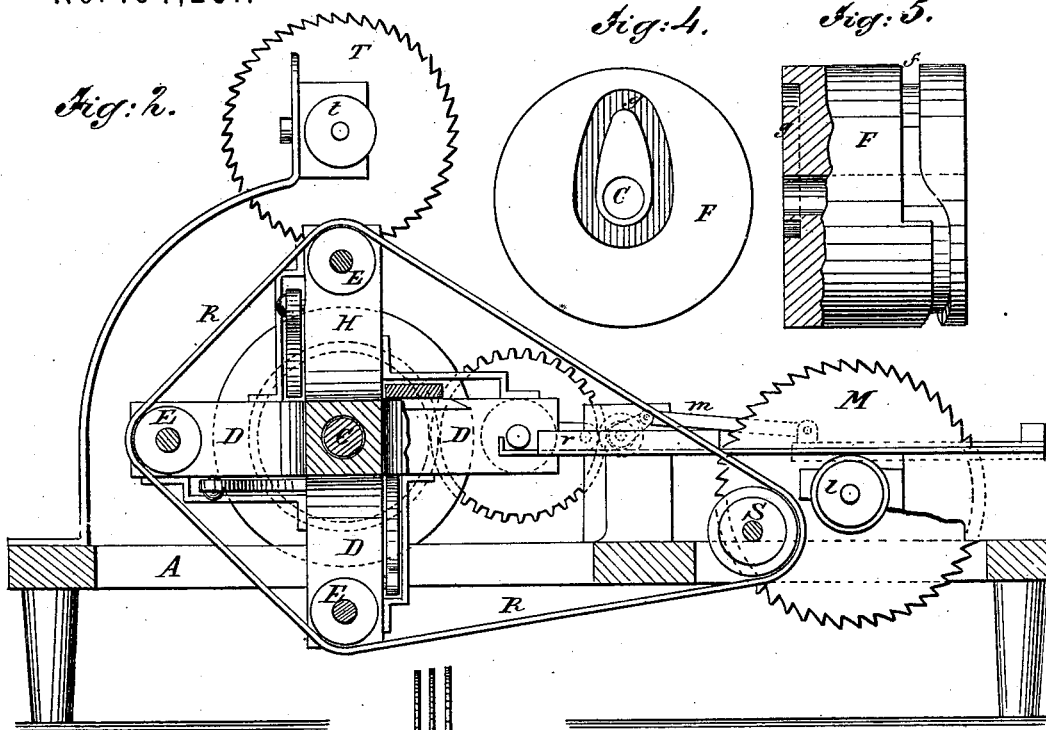

Fig: 4.

Fig: 5.

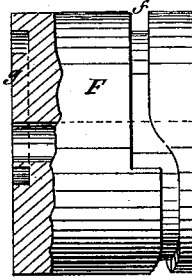
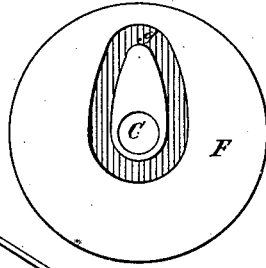

Fig: 1.

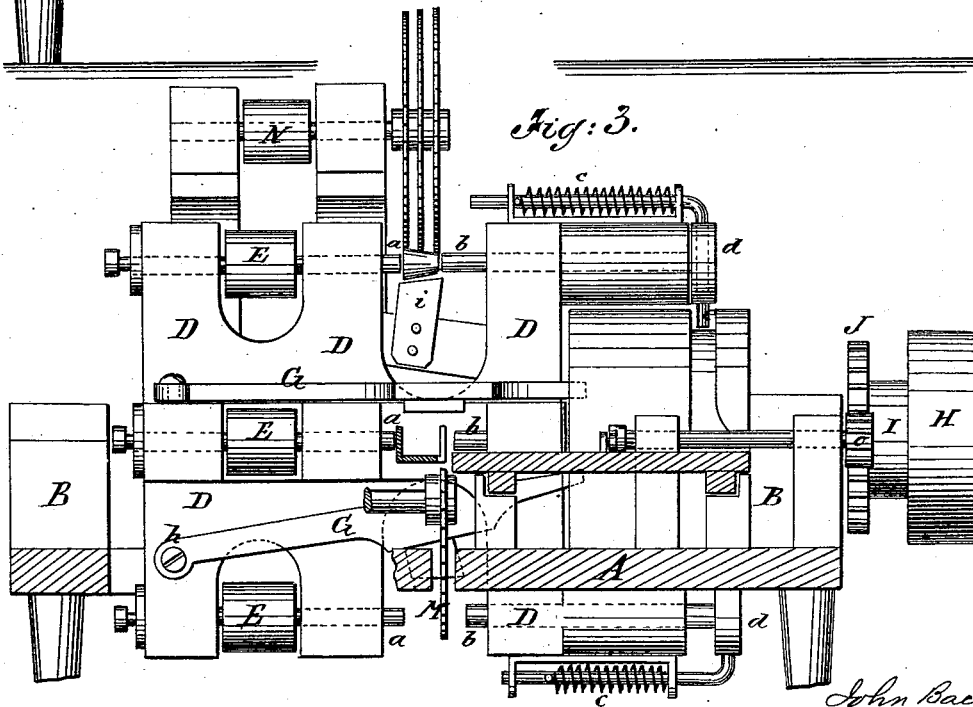

Fig: 3.

Witnesses:

W. Wood.
H. O. Mattenberg

John Bachelder
Inventor:

per
[Signature]
[Signature]

UNITED STATES PATENT OFFICE.

JOHN BACHELDER, OF GARDINER, MAINE.

IMPROVEMENT IN MACHINES FOR CUTTING BUNGS.

Specification forming part of Letters Patent No. 164,251, dated June 8, 1875; application filed March 9, 1875.

To all whom it may concern:

Be it known that I, JOHN BACHELDER, of Gardiner, in the county of Kennebec and State of Maine, have invented a new and useful Improvement in Machines for Cutting Bungs; and that the following is a full, clear, and exact description of the same, reference being had to the accompanying drawings, and to the letters of reference marked thereon, making a part of this specification.

This invention is in the nature of an improvement in bung machinery; and the invention consists in a bung-machine having head and tail spindles that may be independently rotated, and also revolved in stocks, combined with saws, finishing-knives, a fixed operating-cam, and a reciprocated feed-table, substantially as hereinafter specified.

In the accompanying sheets of drawings, Figure 1 is a plan or top view of my invention; Fig. 2, a side elevation, partly in section; Fig. 3, a front-end view; Fig. 4, an end view of cam, and Fig. 5 an edge view of same.

Similar letters of reference indicate like parts in the several figures.

A represents the bed-plate of my bung-machine, to which are secured, in any desirable manner, bearing-blocks B. Passing across the frame or bed-plate A, and resting in suitable bearings in the blocks B, is a shaft, C. Onto this shaft is keyed or otherwise secured one or more head and tail stocks, D. These stocks have fitted to them head and tail spindles *a* and *b*. The shafts of the head-spindles *a* have fitted to them pulleys E, and the tail-spindles *b* are constructed with a spring, *c*, in such manner as to force out from its bearing the tail-spindle when it shall have been retracted. The tail-spindle is also provided with a head, *d*, to the upper side of which is secured a guide for the spring *c*, and to the lower side of which is secured a pin, *e*. Fixed to the bed-plate A is a cam, F, through which the shaft C passes. Into the edge of this cam is an irregular groove, *f*, which passes entirely around its edge, and into its inner face is a groove, *g*. Into the groove *f* passes the pin *e* from the head *d* of the tail-spindle. On the stocks D of the head and tail spindles is fitted a lever, G. One end of this lever is pivoted, as at *h*, and the other end thereof passes

into the groove *g* in the face of the cam F. Secured to this lever, midway between the stocks of the head and tail spindles, as shown in Figs. 1 and 3, is a finishing-knife, *i*, and retaining the lever in position close to the stock of the tail-spindle is a guide, *j*. One end of the shaft C, which projects beyond its bearing, has fitted to it pulley-wheels H and I and a gear-wheel, J. Onto the frame or bed-plate A are fitted guides *k k*, onto which is placed, in such manner as to slide freely thereon, a saw-table, K, to the rear side of which is affixed a spring, L; and resting in suitable bearings, which are also fixed to the frame or bed-plate A, is a circular saw, M. This saw works through a slot in the bed-plate or frame, and close beside the edge of the table K, the shaft of the saw being provided with the ordinary pulley *l*, by which it is driven.

Secured to the face of the table K is a connecting-rod, *m*, one end of said rod extending to a crank-pin, *n*, which is fitted to a crank on a shaft, N, one end of the shaft N having a gear-wheel, *o*, affixed to it, which meshes into the gears of an intermediate wheel, P, to which motion is imparted by the gear-wheel J. Passing around the pulleys E of the head-spindles is an endless belt, R. This belt also passes around a pulley resting in suitable bearings on the bed-plate, and to which motion is imparted by the driving-pulley S. Immediately above the head-spindles, and secured in any suitable manner, is placed one or more circular saws, T, which are caused to revolve by a driving-pulley, *t*. Affixed to the bed-plate or frame A, close beside the saw M, is a trough, *r*.

My bung-machine being constructed substantially as above described, its operation is as follows: Motion being imparted to the shaft C, by means of a belt or otherwise, around the wheel H, the head and tail stocks D of the head and tail spindles are caused to revolve slowly with the shaft, and as they revolve the belt R is caused to revolve by means of a belt around the driving-pulley S, the motion thus imparted causing the head-spindles *a* to rapidly revolve, so that, as the stocks of the head and tail spindles revolve, so do also the head-spindles revolve, but by an independent motion; and as the shaft C revolves

the gear-wheel J, revolving with it, imparts motion to the shaft N through the intermediate gear-wheel P and gear-wheel o, and a reciprocating motion is imparted to the saw-table K through the action of the crank-pin m and connecting-rod n. The circular saw M being also caused to revolve by a belt around its pulley-wheel l, and the circular saw or saws T by a belt around its pulley-wheel t, the whole mechanism is in motion, and a strip of wood, from which the bungs are to be formed, is placed onto and across the table K until its end is brought in contact with the teeth of the saw M, which is effected by the motion of the saw-table K, the reciprocating action of which alternately brings the wood to and from contact with the edge of the saw.

The wood being thus placed, a block is instantly severed from its end, which is deposited in the upper end of the trough r, and as block succeeds block this trough becomes filled throughout its entire length with blocks, when the spring L, which presses against the block next adjacent to it, and thence exerts its force against all of the blocks in the trough, forces the block from the lower end of the trough r, and at the instant this block is so forced out the head-spindle a is brought in a direct line with its center, and the tail-spindle in like position is forced into the block by the action of the spring c, which at that instant is released by reason of the shape of the cam F, which, by means of the pin e working therein, enables the spring, which had theretofore been retracted by the action of the cam, to exert its full force and drive the tail-spindle into the center of the bung-block, and also force the block against the sharpened end of the head-spindle, in this way confining the bung-block between the head and tail spindles, as in an ordinary lathe. The bung-block, being thus confined, is rapidly revolved, and as the stocks D of the head and tail spindles likewise revolve it is carried upward, and brought in contact with the teeth of the revolving saw or saws T, which instantly reduce the block to the required shape. If but one saw is used

for this purpose it may have an inclined vibratory motion imparted to it in any desirable way as it revolves, which will then accomplish this result; or, if a gang or several saws are used for this purpose, they may be of graduated diameters, as shown in Fig. 3, when the same result will be produced. After the bung has thus been shaped, it is carried by the revolving head and tail stocks D in contact with the finishing-knives i, which, by reason of the shape of the groove g in the face of the cam F, are moved and held in contact with the surface of the bung, and rapidly take off a shaving from its surface, leaving the bung smooth and finished, and as it is still carried around and out of contact with the finishing-knives i, the cam F, acting upon the pin e, retracts the tail-spindle b, and withdraws it from the finished bung, allowing it to drop completed in a barrel or other receptacle, and so on, as long as the wood from which the bung is formed is fed to the machine.

Having thus described my invention, what I claim as new, and desire to secure by Letters Patent, is—

1. In a bung-machine, the combination of the revolving head and tail spindles, fixed cam, trimming-knives, and saws, constructed and operating substantially as specified.

2. In a bung-machine, in combination with revolving head and tail stocks, finishing-knives, arranged, constructed, and operated substantially in the manner and for the purpose described.

3. In a bung-machine, the combination of revolving head and tail stocks, finishing-knives, and their supporting-levers with a cam, substantially as and for the purpose described.

4. In a bung-machine, the reciprocating saw-table, provided with the spring L, in combination with the trough r, and the revolving head and tail stocks, substantially as shown and described.

JOHN BACHELDER.

Witnesses:

JOSEPH PERRY,
H. LATHAM.