

J. E. DONOVAN.
Fluting-Machine.

No. 164,272.

Patented June 8, 1875.

Fig. 1

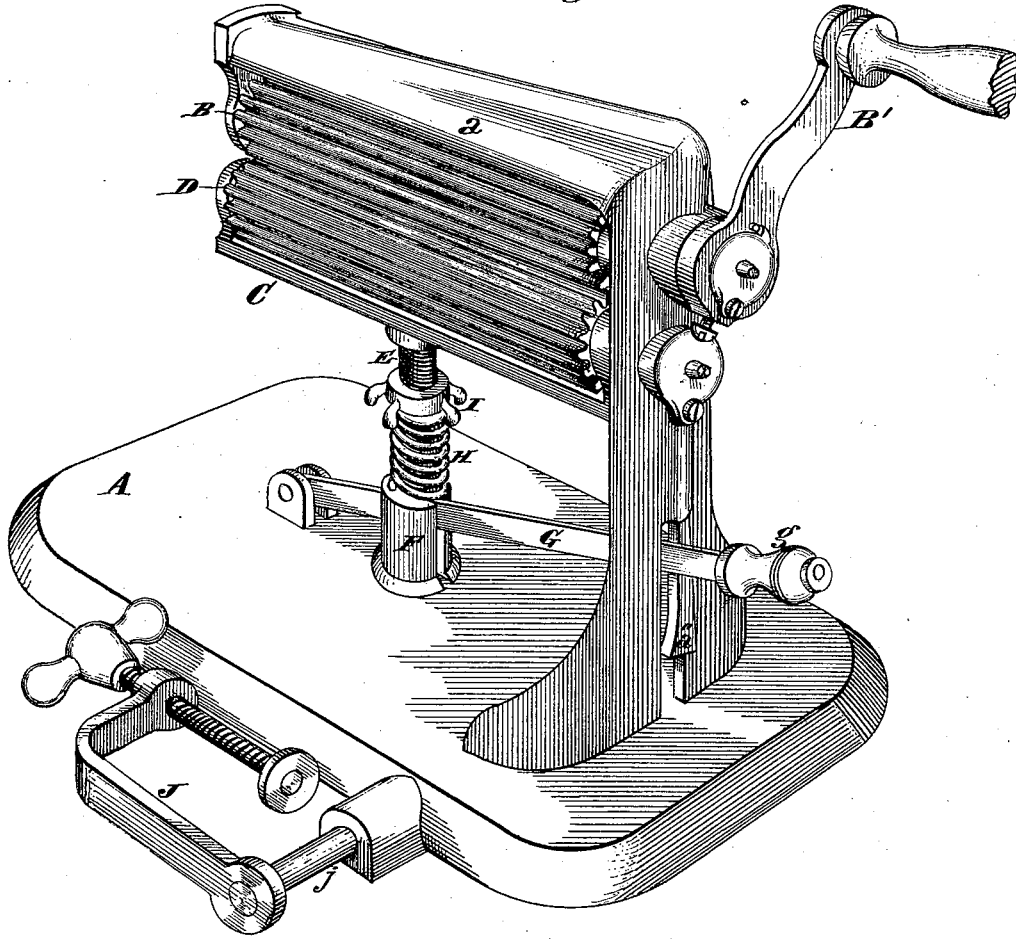

Attest

Edgar J. Cross
John E. Jones

Inventor

John E. Donovan
By F. Millward
Attorney

J. E. DONOVAN.
Fluting-Machine.

No. 164,272.

Patented June 8, 1875.

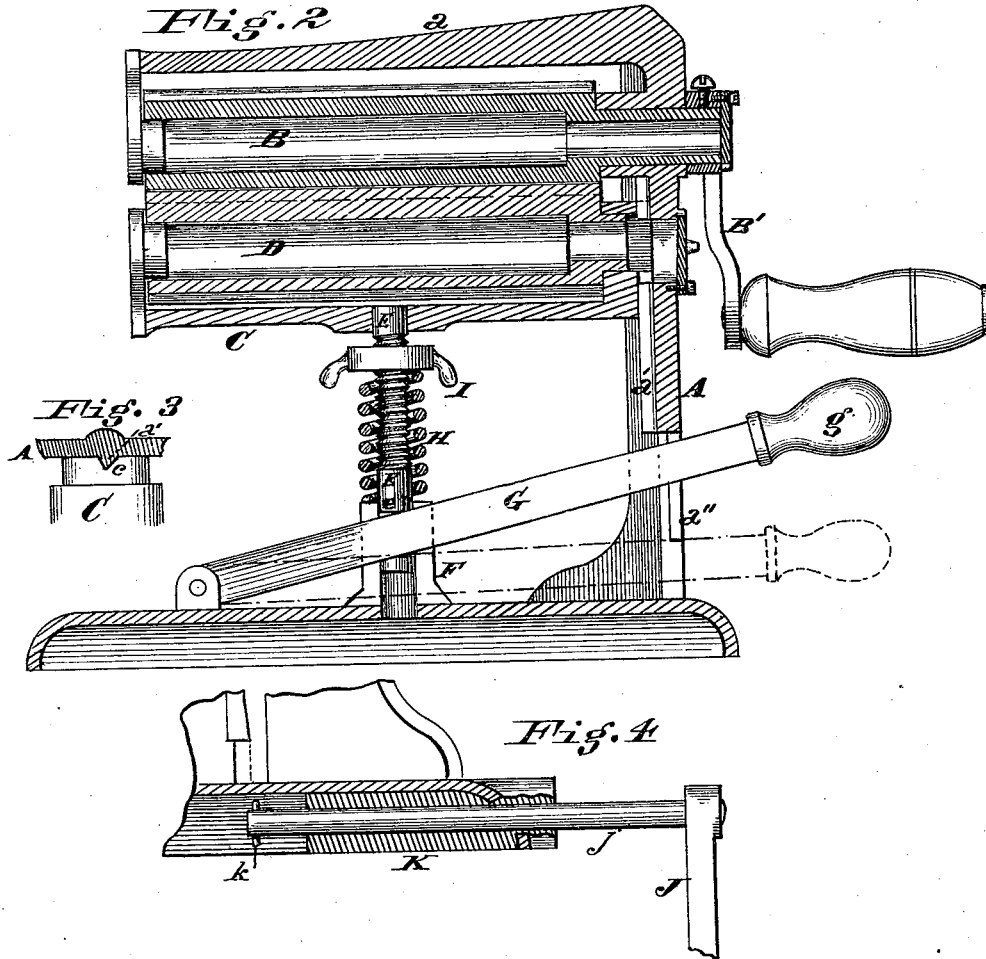

Attest
Edgar Gross
John C. Jones.

Inventor
John E. Donovan
By Y. Millward
Attorney

UNITED STATES PATENT OFFICE.

JOHN E. DONOVAN, OF CINCINNATI, OHIO.

IMPROVEMENT IN FLUTING-MACHINES.

Specification forming part of Letters Patent No. 164,272, dated June 8, 1875; application filed February 18, 1875.

To all whom it may concern:

Be it known that I, JOHN E. DONOVAN, of Cincinnati, Hamilton county, State of Ohio, have invented an Improvement in Crimping-Machines, of which the following is a specification:

My invention consists, in the first part, of a certain peculiar device for depressing the lower roller-frame and returning it into mesh with the upper one, the device being so constructed as to fully support the frame during adjustment. My invention consists, in the second part, in peculiar devices for regulating the power of the spring; and in the third part, in a device for securing the lower roll at the lowest point of its adjustment, to prevent the return by the spring, when necessary.

Figure 1 is a perspective view of a crimping-machine embodying my invention. Fig. 2 is a vertical section of the same. Fig. 3 exhibits the form of sliding connection between the adjustable roller-frame and the main frame of the machine. Fig. 4 illustrates the peculiar construction of my clamp.

A is the main frame of the machine, having the projecting arm *a* to support the outer end of the upper roll B, which is journaled in the frame, as shown, and operated by crank B'. C is the frame, in which the lower roll D is journaled. It has a notched end, *c*, to fit the V-shaped projection *a'* of the frame A, this notch or groove and projection serving as a guide for the vertical movement of the roller-frame C, and as a retaining device to prevent the displacement of the lower roll. To this frame C is secured permanently, as shown, a post, E, which is fitted to slide snugly within a socket, F, cast to the frame A. This post preserves the horizontality of the lower roll, and assists the guide *c a'* in preventing displacement. This socket F is cut across the middle down to the face of the frame A, to receive a lever, G, which passes through a slot, *e*, in the post E. The lever is pivoted to the frame, as shown, and passes through a slot in the frame A, outside of which it is provided with a handle, *g*, by which it may be operated.

By the depression of the lever G the lower frame C is lowered to permit the convenient

introduction of goods between the rollers, the post and socket serving to preserve the proper horizontality of the roll D during and after its adjustment. A coiled spring, H, introduced, as shown, around the post E and between the top of the socket F and frame C, serves to forcibly return the lower roll to its position after depression by the lever. The post E is preferably screw-threaded, as shown, and fitted with an adjusting-nut, I, by which the retractile power of the spring may be regulated, so as to vary the pressure upon the goods between the rolls. A notched projection, *a''*, is secured to the frame A, under which, as shown in dotted lines in Fig. 2, the lever may engage to preserve the rollers wide apart without retaining the hand upon the lever, the lever being slightly flexible to enable its disengagement when necessary. The clamp J, by which the machine is secured to the table, has a long pin, *j*, connected therewith, which is adapted to slide and turn within a socket, K, on the bottom of the frame A, so as to permit the clamp to swing and slide to and from the frame A, a stop-pin, *k*, being introduced to prevent the clamp from being disengaged from the frame A. This construction permits the clamp to swing up and lie compactly over the frame A, for shipment or otherwise.

I claim—

1. The combination of adjustable lower roller-frame C D, slotted post E, socket F, lever G, and spring H, arranged to operate substantially as and for the purpose specified.
2. The combination of adjustable lower roller-frame C D, slotted and screw-threaded post E *e*, socket F, lever G, spring H, and adjustable nut I, substantially as and for the purpose specified.
3. The combination of adjustable lower roller-frame C D, slotted post E, socket F, lever G, spring H, and catch *a''*, substantially as for the purpose specified.

In testimony of which invention I hereunto set my hand.

JOHN E. DONOVAN.

Witnesses:

EDGAR J. GROSS,
J. L. WARTMANN.