

H. K. FORBIS.
Thill-Coupling.

No. 164,286.

Patented June 8, 1875.

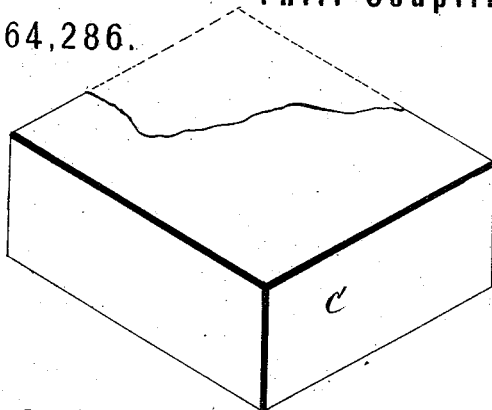

Fig 2

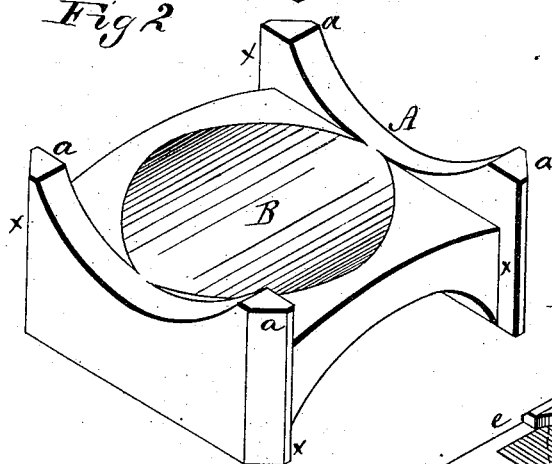

Fig 1

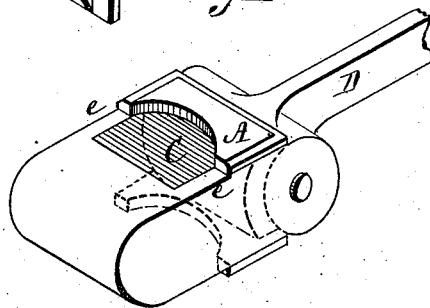
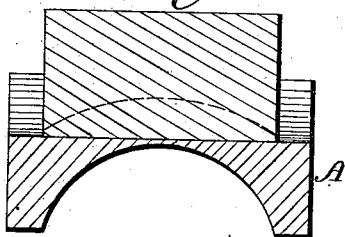

Fig 3



WITNESSES

Franck L. Ourand
C. L. Ewert

INVENTOR

H. K. Forbis
per
Alexander M. Mason

Attorneys

UNITED STATES PATENT OFFICE.

HARBERT K. FORBIS, OF DANVILLE, KENTUCKY, ASSIGNOR OF ONE-HALF HIS RIGHT TO A. H. PEACOCK, OF SAME PLACE.

IMPROVEMENT IN THILL-COUPINGS.

Specification forming part of Letters Patent No. **164,286**, dated June 8, 1875; application filed December 16, 1874.

To all whom it may concern:

Be it known that I, HARBERT K. FORBIS, of Danville, in the county of Boyle and in the State of Kentucky, have invented certain new and useful Improvements in Device for Preventing Shafts from Rattling; and do hereby declare that the following is a full, clear, and exact description thereof, reference being had to the accompanying drawings and to the letters of reference marked thereon, making a part of this specification.

The nature of my invention consists in the construction and use of a metal block which rests upon and between the arms or rings of an ordinary clip having rubber at its back, and the shaft-iron resting against its face, as will be hereinafter set forth.

In the accompanying drawings, Figure 1 is a perspective of a portion of a clip, the rubber, the metal block, and the end of the shaft-iron. Fig. 2 shows the block and also the rubber in perspective. Fig. 3 is a cross-section of the block and the rubber.

In the annexed figures, A represents a metallic block, which is usually made of soft metal. This block is concave upon one side, so that it will fit snugly against the rounded end of the shaft-iron. It has also four projecting corners, *a a a a*, which serve to keep the rubber in place. It also has flanges *x x*, two of which rest upon the wings or arms of the clip, and two stand immediately under it. Between the back of the clip and the back of the block is placed a piece of india-rubber about half an inch in thickness and

large enough otherwise to fit snugly between the corners *a a a a*. The back of the block A is slightly hollowed out, as seen at B, to assist in holding and giving elasticity to the rubber. The shaft-iron presses against the block A, and when the rubber is sufficiently compressed the bolt, in ordinary use, passes through the wings *e e* of the clip, and through the end of the shaft-iron, thus confining the two together.

Any square piece of rubber, C, will answer for this anti-rattler, and it will readily be perceived that oil may be inserted between the block and the end of the shaft-iron D to prevent wear.

I am aware that a thill-coupling having a movable flanged piece with a recess, into which is inserted a rubber block, and against which the thill-iron bears, is not new, being shown in patent of J. H. Jennings, September 27, 1870.

Having thus fully described my invention, what I claim as new, and desire to secure by Letters Patent, is—

The combination of the block A, concave on its front side, provided with recess B in its rear, and having corner projections *a a* and flanges *x x*, with the clip shaft-iron and the rubber block C, all substantially as set forth.

In testimony that I claim the foregoing I have hereunto set my hand this 17th day of October, 1874.

H. K. FORBIS.

Witnesses:

J. M. WALLACE,
J. W. PROCTOR.