

P. HINKLE.  
Hydraulic-Elevator.

No. 164,300.

Patented June 8, 1875.

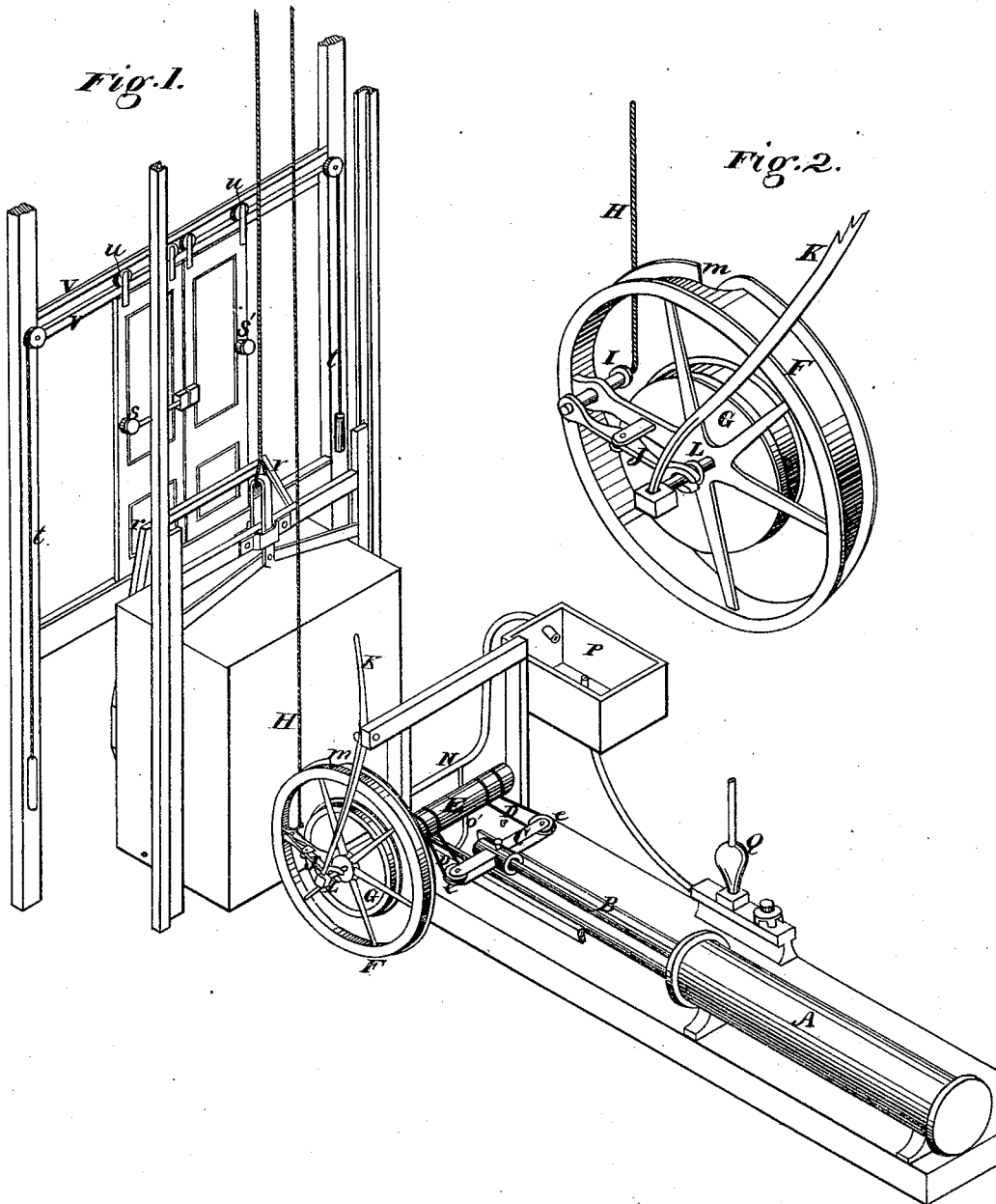

Witnesses  
*Geo. H. Strong*  
*Jno. L. Boone*

Inventor  
*Philip Hinkle*  
by *Dewey & Co.*  
*Attys.*

**P. HINKLE.**  
**Hydraulic-Elevator.**

No. 164,300.

Patented June 8, 1875.

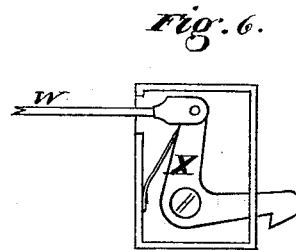
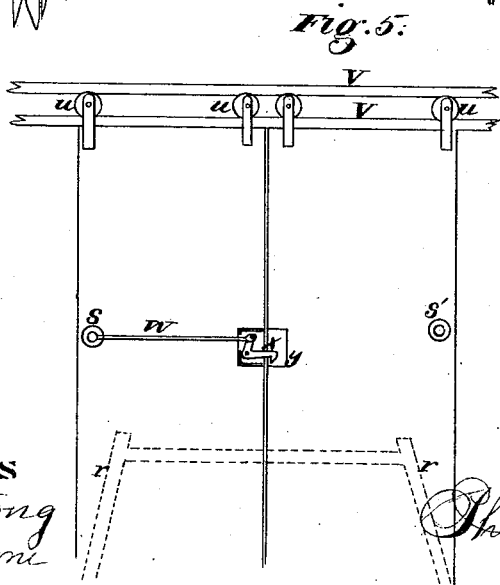
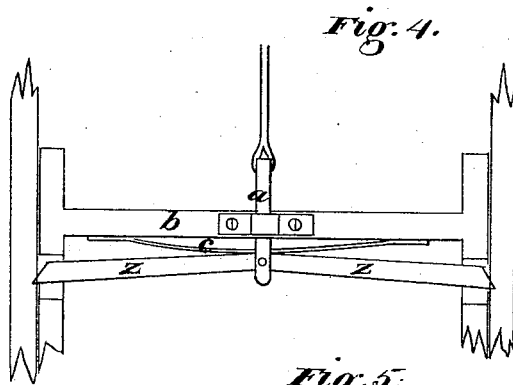
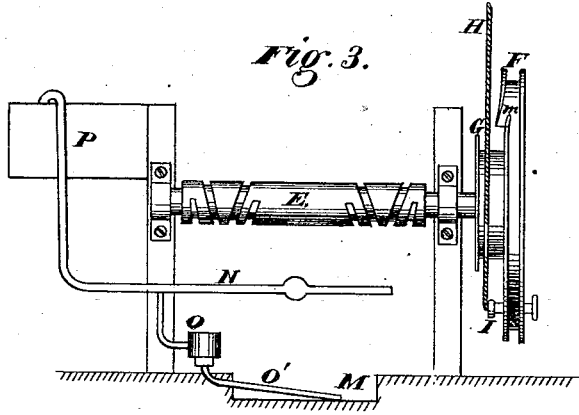

**Witnesses**  
*Geo. H. Strong*  
*John L. Burns*

**Inventor**  
*Philip Hinkle*  
 by *Devey Co*  
*Attys*

# UNITED STATES PATENT OFFICE.

PHILIP HINKLE, OF SAN FRANCISCO, CALIFORNIA.

## IMPROVEMENT IN HYDRAULIC ELEVATORS.

Specification forming part of Letters Patent No. **164,300**, dated June 8, 1875; application filed March 1, 1875.

*To all whom it may concern:*

Be it known that I, PHILIP HINKLE, of San Francisco city and county, State of California, have invented an Improvement in Hydraulic Elevators; and I do hereby declare the following description and accompanying drawings are sufficient to enable any person skilled in the art or science to which it most nearly appertains to make and use my said invention or improvement without further invention or experiment.

My invention relates to certain improvements in the hydraulic elevators, and the working parts connected therewith, by which I am enabled, first, to make the cage open and close the doors at the different landings automatically by its rise and fall.

My invention also consists of a novel device for changing the power and adapting it to heavy or light loads.

Referring to the accompanying drawing for a more complete explanation of my invention, Figure 1, Sheet 1, is a perspective view of my invention. Fig. 2 is an enlarged view of the double hoisting-pulley. Fig. 3, Sheet 2, is a view of the pulley, drum, and water-exhaust. Fig. 4 is a view of the safety-catch. Fig. 5 shows the door and lock. Fig. 6 shows the lock.

A is a horizontal cylinder, having within it a piston moved by the pressure of water which is admitted by suitable valves. B is the piston-rod, having a cross-head, C; and to this cross-head the pairs of ropes or chains D are attached, passing around pulleys *e* in the ends of the cross-head, so as to equalize the strain upon them. The cross-head is also loosely secured to the piston-rod, and assists to equalize the strain upon the ropes in the same manner as described in my patent granted July 1, 1873. The opposite ends of the ropes D pass around the drum E, winding in the spiral grooves, as shown.

In some cases I employ a swiveling bar at each end of the cross-head or yoke C, and a pulley at each end of these bars, making four pulleys and eight parallel ropes. By this combination of my swiveling yoke or yokes with the pulleys I am enabled to employ any number of ropes, which can be made correspondingly smaller, and the strain upon all of

the ropes will be equal. If either of the ropes breaks the others will hold until this can be repaired.

The spiral grooves in the drum are made in pairs, so that the pairs of ropes from each pulley will lie close together when the yoke is farthest from the drum, and will coil outward from each other, so as to lie nearly parallel when the yoke is close to the drum.

The elevator-pulley is secured to this drum-shaft, and consists of two different-sized wheels, F and G, provided with a device for shifting the rope H which hoists the cage, so that for light loads the rope may be coiled upon the larger pulley F; and thus the cage may be hoisted to its highest point with a movement of the piston through only a small part of the length of the cylinder, and a consequent saving of water.

When a heavy load is to be raised the rope may be allowed to coil upon the smaller pulley G, and the piston will then traverse the full length of the cylinder.

In order to shift the rope H readily from one pulley to the other, it is secured to a strong pin, I, which slides through a boss upon one of the arms of the pulley F. A lever, J, has its fulcrum upon the outside of this arm, and one end is secured to the pin I, while the other clasps a collar upon a pin, L, which loosely enters the center of the wheel-hub, so that the lever J can turn around with the wheel, and still be operated by means of the hand-lever K, which is attached to the pin L, and extends up to the frame within easy reach, or it may enter the corner of the cage. The flange of the pulley F which is nearest to the pulley G is bent down and grooved, as shown at *m*, so that when the pin I is drawn outward, so that the rope H lies close to the pulley F, it will be caught by this projecting lip and caused to coil upon the large pulley; but when the pin is forced inward the rope will coil upon the small pulley without touching the lip.

The pipe N, by which the water escapes from the cylinder, is provided, at O, with my relief-valve, (for which application for a patent is now pending,) and the pipe of the valve has an extension, O', which draws up any water which leaks into the tank or depression M, in the manner of an injector. The water escapes

into the tank P, which is situated just high enough to allow the water to run a hydraulic ram, Q, as shown. This ram forces a certain proportion of the water up into an elevated tank, so that it may be used sometimes to run the hoisting-cylinder, and save some expense of water.

In order to operate the doors at the different landings automatically and prevent the danger of their being opened at improper times, while they are always opened when the cage arrives, I fix two pairs of arms, *r r*, to the front of the cage. These arms approach each other both upward and downward from the center, which is the widest part, and as the cage arrives at any door these arms engage rollers *s s'*, which project from the back of the doors, and, after unlocking the doors by the first contact, they press them apart so that they are wide open when the cage has arrived at the level of the landing, and they will be closed after the cage passes by ropes *t*, properly attached and extending to springs or weights at the side, as shown. The doors are mounted upon rollers *u* at the top, and these rollers move between parallel tracks *v*, so that there will be no jar or catch.

The unlocking device is constructed as follows: The roller *s* is mounted upon a shaft which is pivoted within the thickness of the door, so that the roller may have a little motion from side to side, and, as the arm *r* strikes this roller an instant before the opposite roller is touched, it will be thrown back a short distance. An arm, W, extends from the roller-shaft to the inner edge of the door and connects with one arm of a bell-crank lever, *x*. The other arm of the lever is formed into a catch, and it is held down by a spring, so as to engage with the holder *y* upon the opposite door at all times until the roller is forced back by the contact of the arms *r*. This frees the catch, and the doors will then be opened by the further action of the arm *r* upon the rollers *s s'*.

The safety-stop employed consists of two arms, *z z*, which extend across the top of the cage and have their outer ends beveled off sharply, so that they will press into the guides when they are in a straight line, and thus hold the cage in its place if the rope H breaks.

The inner ends of these arms are attached to the bottom of the link *a*, the rope being secured to the top, and as the weight of the cage comes upon it the link will slide up until the

inner ends of the arms *z* touch the cross-beam *b*.

This effectually prevents any contact between the ends of the arms and the guides as long as the rope holds.

In order to insure the locking of this catch in case of accident, I fix a spring, *c*, beneath the beam *b*, and this spring presses constantly upon the center where the arms *z* meet, so that any relaxation of the rope will allow the spring to force the arms downward till their outer ends are fixed in the guides.

By this construction the whole weight of the cage may be supported upon these arms without any outward pressure, which would have a tendency to force the guide-timber apart.

Having thus described my invention, what I claim, and desire to secure by Letters Patent, is—

1. The pulleys F and G, of different sizes, secured side by side upon the same shaft, the pulley F, having a lip, *m*, in combination with the shipping mechanism, by which the rope can be run upon either one of the pulleys, substantially as and for the purpose set forth.

2. The lever J, having its fulcrum upon an arm of the pulley F and attached to the pin I, together with the lever K and central pin L for operating the lever J and shifting the rope H from one pulley to the other, substantially as herein described.

3. In combination with one or more swiveling cross heads or yokes, C, the pulleys *e*, with the ropes D in pairs and winding upon the drum E spirally, substantially as and for the purpose herein described.

4. The escape-pipe N, with the branch-pipe extension O' to draw away waste water from the tank M and discharge it into the tank P, substantially as herein described.

5. The device consisting of the inclined planes or arms *r r*, secured to the cage, and the pulleys or rollers *s s'* upon the sliding doors, together with the cords *t* and the weight or springs for opening and closing the doors as the cage arrives opposite to them and departs, substantially as herein described.

6. The roller *s*, mounted upon a vibrating shaft, and the arm *w* and bell-crank lever *x*, so constructed as to operate as a latch, which is operated by the arm *r*, substantially as herein described.

PHILIP HINKLE.

Witnesses:

GEO. H. STRONG,  
JNO. L. BOONE.