

F. H. BETTYS.

Device for Operating Curtain-Rollers.

No. 164,361.

Patented June 15, 1875.

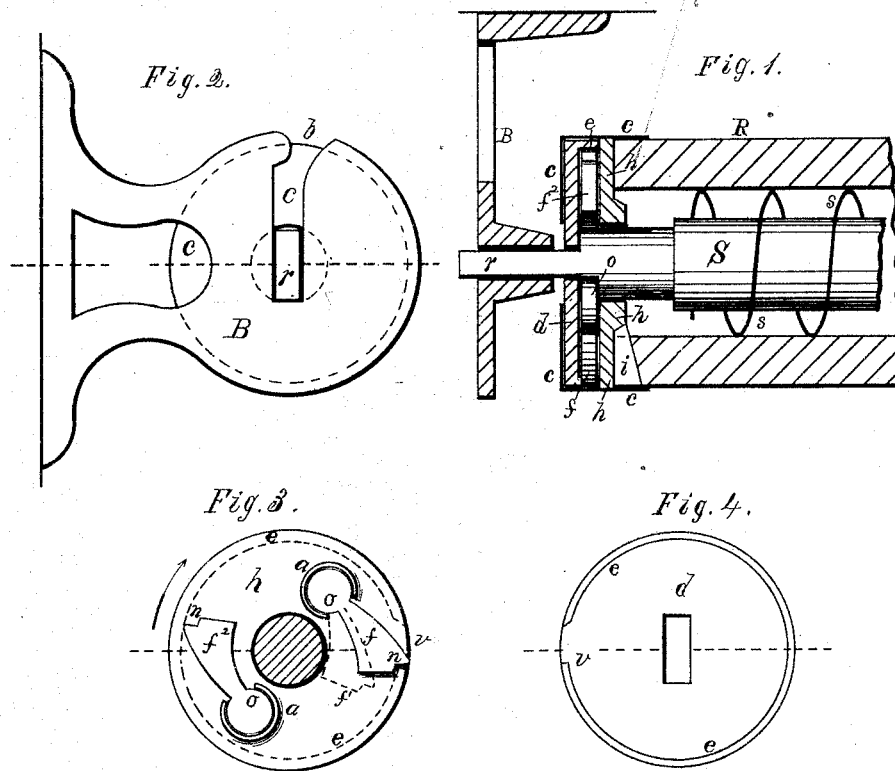

Witnesses:

E. B. Whitmore
Jra Loughborough

Inventor:

F. H. Bettys
By Jra Loughborough
Atty

UNITED STATES PATENT OFFICE.

FREEMAN H. BETTYS, OF ROCHESTER, NEW YORK, ASSIGNOR TO S. B. ROWE, JR., OF SAME PLACE.

IMPROVEMENT IN DEVICES FOR OPERATING CURTAIN-ROLLERS.

Specification forming part of Letters Patent No. **164,361**, dated June 15, 1875; application filed May 15, 1875.

To all whom it may concern:

Be it known that I, FREEMAN H. BETTYS, of Rochester, in the county of Monroe and State of New York, have invented certain new and useful Improvements in Spring Curtain-Rollers; and I do hereby declare that the following is a full, clear, and exact description thereof, reference being had to the accompanying drawings making part of this specification, in which—

Figure 1 is a top sectional view of one end of a roller having my invention attached. Fig. 2 is an end view of the roller as hung in the bracket. Fig. 3 is an elevation of the head *h*, with the pawls *f* and *f*² in place, the two caps *c* and *d* being removed.

This invention consists, mainly, in the employment of a sort of primary cap inclosing the pawls, and fixed to the spindle, so as not to rotate, whereby it is made to act as a stop to lock the pawls and hold the curtain at the desired elevation.

I use an ordinary bracket, B, having a vertical slot, *b*, to receive the flattened section *r* of the spindle S. The roller R, spindle S, and spring *s* are the same as those in common use in this class of curtain-fixtures. The head *h* is formed with two or more thin radial webs, *i*, upon the inner face, which are forced into the end of the roller-shell, and thereby cause them both to remain at rest or revolve together. The head is provided on the opposite side or outer face with two circular sockets, *a*, Fig. 3, arranged on opposite sides of the center. The pawls *f* and *f*² are formed with heads *o*, to fit into these axial sockets. The pawls are also each formed with a notch, *n*, to catch upon the edge of the rim *e* of the head *d* in the notch *v*, Fig. 4. In this figure the inner face of the head or cap *d*—that is, the face of the cap or head shown in the figure—is placed contiguous to that of the head *h*, as shown in Fig. 2, and its rim *e*, indicated by the dotted circle in Fig. 3. As before stated, the head *h* revolves with the roller, while the cap *d* remains in a fixed position. The spindle S, head *h*, and cap *d* are secured to the roller by means of a secondary or outer cap, *c*, of thin metal, the rim of which may be made to project, so

as to reach onto the end of the roller as far as desired, where it may be secured by one or more small pins, or otherwise.

The pawls may be attached to the head *h* by rivets, if desired.

The cap *c* would be just as efficient in securing the parts in their proper relations if it was formed with a flange of only one-eighth of an inch or so, instead of extending nearly to the center.

The cap *d* should be placed upon the spindle with the notch *v* outward or from the casing of the window when the spindle is adjusted in the bracket B. This would place the notch, as indicated by the space at *v*, in the dotted circle in Fig. 3. Therefore, as will be seen, when the roller is caused to revolve slowly in the direction of the arrow, the pawls, by their gravity, will drop to the position indicated by the dotted lines *f* without catching in the notch *v*; but when the roller is permitted to revolve rapidly a pawl, by its centrifugal force, is driven into the notch *v*, and made to lock the roller and prevent any further revolution until again released, and the roller allowed to turn slowly.

Thus it will be seen that the spring can never, by any possibility, "run away" with the roller and curtain, which so frequently occurs with the spring-fixtures of ordinary construction.

What I claim as my invention is—

1. In combination with the roller R, spring *s*, spindle S, revolving head *h*, and pawls *f* and *f*², the fixed primary head or cap *d*, provided with a notched rim, *e*, substantially in the manner and for the purposes set forth.

2. In combination with the revolving head *h*, pawls *f* and *f*², and fixed primary cap *d*, the secondary cap *c*, substantially as and for the purposes set forth.

3. In combination with the notched rim *e* of the cap *d*, the pivoted or swinging pawls, provided with the stop-notch *n*, as and for the purposes set forth.

F. H. BETTYS.

Witnesses:

WM. S. LOUGHBOROUGH,
E. B. WHITMORE.