

E. MILL.
Paper-Bags.

No. 164,389.

Patented June 15, 1875.

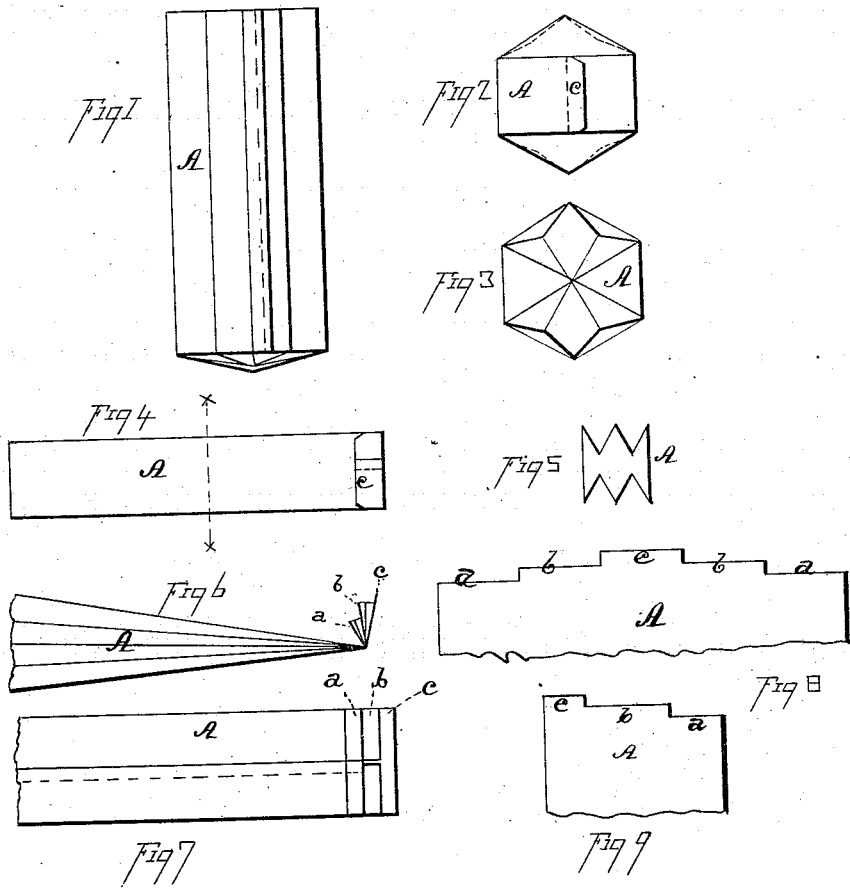

WITNESSES
 Walter Miller
 Wm Ewart

INVENTOR
 Edward Mill
 By Leggett & Leggett
 Attorneys

UNITED STATES PATENT OFFICE.

EDWARD MILL, OF CLEVELAND, OHIO.

IMPROVEMENT IN PAPER BAGS.

Specification forming part of Letters Patent No. **164,389**, dated June 15, 1875; application filed May 18, 1875.

To all whom it may concern:

Be it known that I, EDWARD MILL, of Cleveland, in the county of Cuyahoga and State of Ohio, have invented certain new and useful Improvements in Paper Bags; and I do hereby declare the following to be a full, clear, and exact description of the invention, such as will enable others skilled in the art to which it pertains to make and use it, reference being had to the accompanying drawings, which form part of this specification.

My invention relates to an improvement in paper bags; and consists, first, in forming the said bag with a hexagonal bottom; second, in forming the bag with double folds along the edge, substantially as hereinafter set forth and claimed.

In the drawings, Figure 1 represents a paper bag embodying my improvements. Fig. 2 is a bottom view of same; Fig. 3, a top view of same. Fig. 4 represents the bag as it appears before using it—that is, the form in which it is presented to the trade. Fig. 5 is a cross-section on the line *x x*. Fig. 6 is a side view; Fig. 7, a plan view, showing the condition of the paper and its folds prior to the pasting down of the ends. Fig. 8 represents a piece of paper cut to the proper pattern for forming the paper bag. Fig. 9 represents the same when folded to the form of a tube, or shows the pattern to which the paper tubing should be cut.

It is frequently desirable to employ a paper bag that shall make a cylindrical or nearly cylindrical package when filled, and yet the paper bag be of such a nature that it can be readily folded and pasted upon a flat surface, and present, when completed, the flat form of an ordinary paper bag.

I accomplish this by forming the paper bag with a hexagonal bottom—that is, so that when filled the paper will dispose itself so as to leave the bottom of the bag hexagonal in form; and this is accomplished by a very simple process of folding and pasting which I will now proceed to explain.

If made from plain paper sheets, the first operation is to paste its edges so as to form a tube; but if made from paper tubing, this operation in the construction of separate bags is, of course, dispensed with.

I take a suitable length of paper tubing, as shown in Fig. 9, and it is cut into the pattern there shown.

A is the paper tubing. *a b c* are the portions which will in the final construction of the bags form the lapels, to which the paste is applied. The paper is then folded to the shape shown in cross-section in Fig. 5, when it will present the appearance shown in Figs. 6 and 7. Paste is then applied to the lapels *a, b, and c*, and they are folded over, as indicated by the dotted lines in Fig. 6, which completes the bag, and it will then have the appearance shown in Fig. 4.

It will be seen that this manner of folding the paper tube makes two folds or plications upon each side. Each of these folds or plications correspond to one of the sides of the hexagonal bottom, and the top and bottom of the flat portions form the remaining two sides of the hexagonal bottom.

When this bag is opened out and filled, the paper at the bottom of the bag will naturally dispose itself so as to leave a hexagonal-shaped bottom to the package, and the package itself will be cylindrical or nearly so.

It is evident that this paper bag can either be made by hand or by machinery, and that ordinary machinery for making paper bags of the ordinary kind, wherein the lapel is pasted over upon the side of the bag, can be employed for folding down and pasting the lapels upon this bag.

What I claim as new, and desire to secure by Letters Patent, is—

1. A paper bag folded into a flat shape, substantially as described, with two plications upon each of its edges, whereby the paper composing the bag is, in the operation of filling, distended into a cylindrical package with a hexagonal-shaped bottom, substantially as and for the purpose described.

2. The process of forming a cylindrical paper bag with a hexagonal-shaped bottom, consisting of first forming upon a sheet or tube of paper the lapels *a, b, and c*, then folding the said tube with two longitudinal plications upon each edge, and finally simultaneously pasting down the lapels, in the manner and for the purpose substantially as set forth.

In testimony whereof I have signed my name to this specification in the presence of two subscribing witnesses.

EDWARD MILL.

Witnesses:

H. T. HOWER,
FRANCIS TOUMEY.