

C. T. GRILLEY.

Mechanism for Forming Leather Washers.

No. 164,445

Patented June 15, 1875.

Fig. 1.

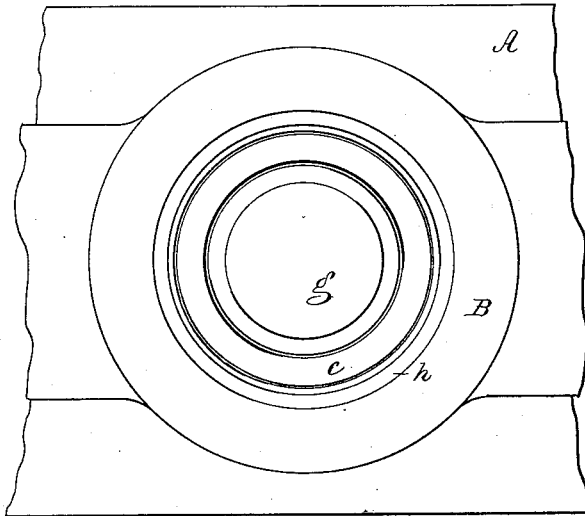

Fig. 2.

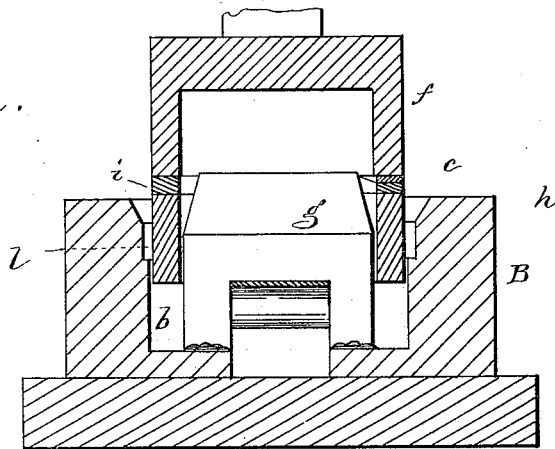
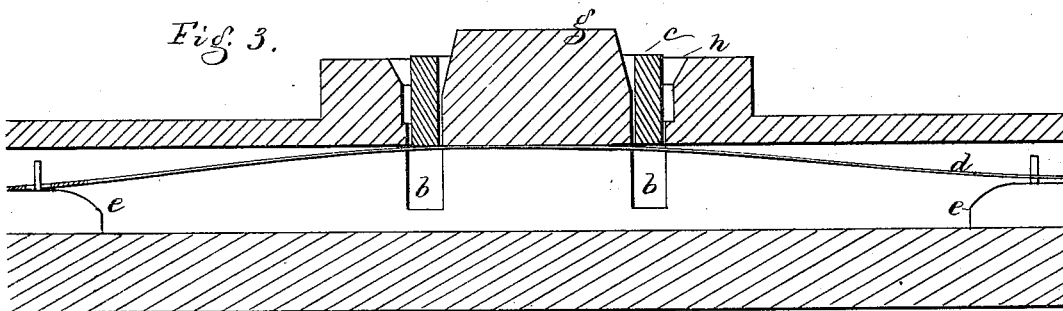

Fig. 3.



WITNESSES
L. H. Lattimer.
Wm. Pratt.

INVENTOR.
Charles T. Grilley
Per Lewis J. Angory

UNITED STATES PATENT OFFICE.

CHARLES T. GRILLEY, OF BOSTON, MASSACHUSETTS.

IMPROVEMENT IN MECHANISMS FOR FORMING LEATHER WASHERS.

Specification forming part of Letters Patent No. **164,445**, dated June 15, 1875; application filed April 14, 1875.

To all whom it may concern:

Be it known that I, CHARLES T. GRILLEY, of Boston, Suffolk county, Massachusetts, have invented an Improved Mechanism for Forming Leather Washers, of which the following is a specification:

This invention relates to a mechanism for forming leather washers from strips of waste, scrap, or other leather, such as are fully described in another application heretofore made and filed by me at the United States Patent Office, and to which reference may be had.

Washers as heretofore made for packing purposes have been made of india-rubber and of leather. Those of india-rubber are very expensive, and when they are to come in contact with oil are objectionable, because the oil soon destroys the rubber. Those of leather, as heretofore made, have been cut as flat rings from sides of leather, washers of the largest size being first cut, and then from the interiors of such large washers are cut smaller washers down to the smallest washer used. In this process of cutting washers there is no actual waste of leather, except the pieces from between the peripheries of the large washers and the small pieces punched or cut from the smallest washer. In the manufacture of washers, however, in this way good leather is used in sides, and worth from forty to forty-five cents per pound, and there are always made as many small as large washers. It is not, therefore, possible to cut and supply an order for washers of a given size without at the same time making as many washers of other sizes, and in this way the stock of a washer-manufacturer is rendered unnecessarily large, making it necessary to hold sizes for which there is not much demand, and for large washers made to order it is necessary to charge a price not according to the quantity of leather in the washer, but according to the quantity of leather rendered then unproductive in small washers.

Figure 1 is a top view of the die in which this washer is pressed into shape. Fig. 2 is a cross-section through the die, and Fig. 3 a longitudinal section.

A represents the plate to which the female die B is attached. This die B has an annular

passage, *b*, for the reception of the annular follower *c*, resting on a spring, *d*, supported at its outer ends on projections *e e*, the tendency of the spring being to elevate the follower, as shown in Fig. 3, when not held down by the male die or plunger *f*. Within the annular chamber *b* rises a central core, *g*, preferably beveled at top, so that the washer can be easily passed over the core and down onto the follower and into the annular chamber *l*, in which the washer is formed. The taper of the core extends below the beveled portion *h* of the female die, so that the washer may always have a support about its outer edge before it is at all expanded or stretched, as must be the case to a small extent when a washer is being formed.

In the manufacture of this washer, I first take pieces of leather—such as are commonly thrown away as the waste in the manufacture of boots and shoes—and pass them through a machine adapted to skive and leave them of substantially even thickness. Then I prefer to place said pieces, one edge having been straightened by cutting, against a straight-edge or guide, and under the action of a knife, which descends and cuts the leather into strips of the desired width and length, and with ends beveled to allow the end of the strip, when bent into circular form, to meet evenly. The strip of leather, bent into circular shape, is then placed in a female die, B, and about a core, *g*, and a male die, *f*, then forces the leather *i* into the female die, causing it, by pressure, to assume and retain a circular form, the edges *b b* meeting and lapping, if desired.

Instead of the ends being cut I may shoulder the ends, the shoulders lapping and fitting, as shown in my application heretofore filed; or I may cut the end on a bevel of greater or less length, and lap the ends, as shown at the left of Fig. 2.

The washers may be made to present as wearing-surfaces the outer and inner sides of the leather; but it is evident that I may stand the washer-forming strip on edge, and bend it then into a circle, preparing its ends in any of the ways indicated, and a leather washer so bent and made will present the

end of the grain of the leather as the wearing surface. Washers made in both these ways work well.

If it is desired to attach the ends of the washers together it may be done in the following way: Before the strips of leather are bent into circular form they may be coated with india-rubber cement, or other leather-holding cement which will not be affected by water or oil, and the edges, when lapped and united under pressure, will be set and fastened. The leather back from the ends may be moistened a little, if desired, to facilitate its molding to shape. Instead of cutting the leather into strips, as described, it may be formed into strips in any other suitable way.

I prefer to make my washers of strips of waste leather, as described; but it is evident that I might purchase good leather and cut it into strips of the desired width, and thereby materially cheapen the manufacture of washers, for I could manufacture any desired number of washers of even thickness and density, and of any given size or thickness, and need not produce, as in the old way, as many—perhaps then unsalable washers—as I produce of washers of the desired size, and I need charge only for the actual amount of leather used; so I do not desire to limit myself to the production of my washers from waste leather alone, but when I produce them entirely of waste leather I am enabled to reduce the cost to the very lowest degree.

It will be noticed that my washer is composed, as usual, of a single layer of leather, except where the ends of the strip are lapped; and at that point the ends of the strip are notched or reduced, and are lapped but for a short distance.

In the manufacture of this improved washer I have alluded to the fact that small washers are cut from larger ones; and it is well understood that large washers are usually required to be thicker than small washers, and therefore when a large washer is cut from a side or piece of leather of the proper thickness the smaller washers made from the interior are too thick, and when used by the consumer have to be cut or made thinner by hand, resulting in a waste of time and stock. Furthermore, the washers, as usually cut from sides of leather, are not of even thickness, because the thickness and compactness of the leather varies at different portions of the side; and this want of uniformity must exist in the washer, as it is not practical to skive the side before cutting the washers, and were this skiving practical it is apparent that great loss would result in bringing a full hide to uniform thickness, or to the thickness of the thinnest part, and a most valuable portion of the hide would be lost.

In a washer of not uniform density it will be apparent that when met by metallic or other surfaces which it is to pack that por-

tion of the washer the most dense will regulate the distance between the metallic surfaces, and the other portion, less dense, will permit the passage of air or liquid, provided the washer is used to pack a liquid or air joint.

My improved washer of waste strips, it will be seen, can be practically made of uniform and of any desired thickness by skiving and pressure; whereas with other washers they are reduced in thickness by hand when being applied, which is a tedious operation, and by such hand-cutting the washer is not kept of even thickness.

I have also alluded to the fact that this my improved washer may be made from strips of leather cut from the side or hide; but such a washer would be much more expensive, for the strips, besides costing so much more than waste leather, would not be of uniform thickness; and if such strips were skived to uniform thickness there would result a waste too serious to warrant the profitable manufacture of washers, as compared with their manufacture from waste strips.

In the use of a washer of not uniform thickness and density in a carriage-wheel, or where it is subjected to friction between surfaces, if one portion of the washer is hard and holds the surfaces apart, while another part is soft and does not touch the parts as firmly, the hard part receives the greatest wear, and has a tendency to throw an unequal strain on the axle at the end; and in this use of a washer, if the washer is of even thickness, and not of uniform hardness, the softer portion will wear out before the harder, and cause the wheel to run irregularly and with a jar.

The washer *i*, first bent into substantially annular form, is placed over the core *g* on the follower *c*. The male die *f* then descends and forces the follower and washer into the chamber *b*, compressing the washer into shape and compacting it, and, if the ends have been cemented, uniting such ends firmly. The male die then rises, and the spring *d* elevates the follower and lifts the washer, so that it can be easily removed and a new one applied.

Instead of the flat spring *d*, any other well-known class of spring may be used, and other means than the follower *c* might be used to remove the washer from the chamber *b*, and in such case the follower and spring might be dispensed with.

The male die or the female die may be connected with and operated by slide-rods, or in any other well-known way suitable to give them motion toward and from each other at the proper intervals of time.

The two members of the die form a press for consolidating the washers.

Having described my invention, I claim—

1. The mechanism for forming leather washers, consisting of the die *B*, core, and plunger,

constructed and operating substantially as described.

2. The combination, with the dies and core, of the follower and spring, substantially as described.

3. The process of forming leather washers composed of a single layer or thickness of leather, consisting in cutting the strip into the desired length and thickness, then bending the strip into annular form, and complet-

ing it in dies under pressure, substantially as described.

In testimony whereof I have signed my name to this specification in the presence of two subscribing witnesses.

CHARLES T. GRILLEY.

Witnesses:

G. W. GREGORY,
S. B. KIDDER.