

W. HANKIN.
Saw-Frame.

No. 164,449.

Patented June 15, 1875.

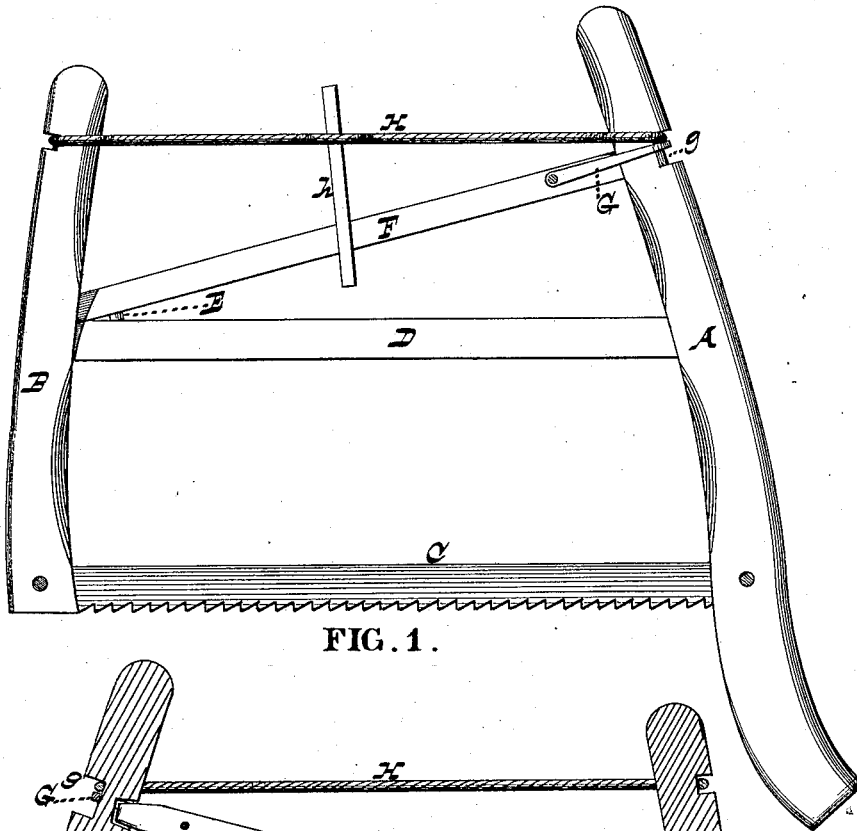

FIG. 1.

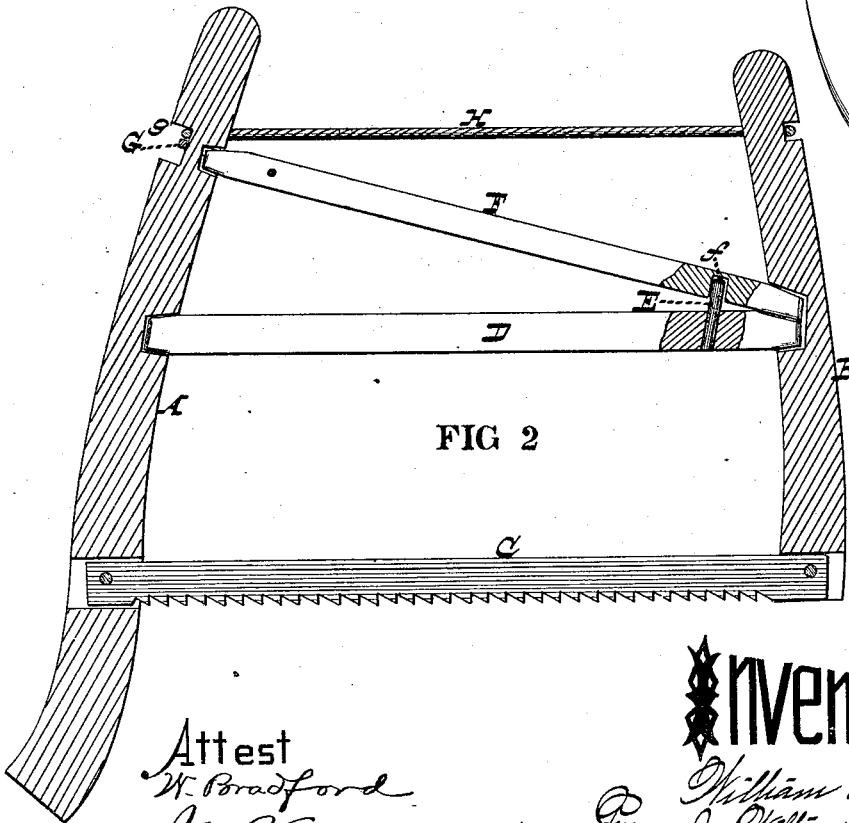

FIG 2

Attest
W. Bradford
J. R. Colburn

Inventor
William Hankin
J. William Hankin

UNITED STATES PATENT OFFICE.

WILLIAM HANKIN, OF SEELYVILLE, PENNSYLVANIA.

IMPROVEMENT IN SAW-FRAMES.

Specification forming part of Letters Patent No. **164,449**, dated June 15, 1875; application filed May 21, 1875.

To all whom it may concern:

Be it known that I, WILLIAM HANKIN, of Seelyville, in the county of Wayne and State of Pennsylvania, have invented a certain new and useful Improvement in Saw-Frames, of which the following is a full, clear, and exact description, reference being had to the annexed drawing and the letters of reference marked thereon, in which—

Figure 1 is a side elevation of my improved buck-saw, and Fig. 2 is a view thereof, partly in section and elevation.

Corresponding parts in the two figures are denoted by like letters.

This invention relates to a certain improvement upon my Letters Patent No. 129,731, granted July 23, 1872; and it consists in the detachability of the diagonal brace from the saw-frame, and the locking of the same to the horizontal or middle bar of said frame, substantially as hereinafter more fully set forth.

To enable others skilled in the art to which my invention appertains to make and use the same, I will proceed to describe it.

In the annexed drawing, A refers to the saw-handle, and B to a similar but shorter piece, the two constituting the side pieces of the saw-frame, within which the saw-blade C is suitably secured. D is a horizontal bar connecting the parts A and B together about midway of their lengths. Firmly secured within and projecting above the said bar D obliquely to its longitudinal axis, as seen in Fig. 2, is a stud or stout pin, E, the function of which will appear hereinafter. F is a diagonal brace reduced or tapered at its ends, as are also those of the horizontal bar D and entering mortises in the side pieces A and B. The rear end of the brace F is provided in its

lower side with a socket, *f*, as shown in Fig. 2, to receive the projecting portion of the stud or pin E, by which it is locked to the bar D, the opposite ends of said brace and bar being secured, as shown in the drawing, to give them a firm joint-bearing in the side piece B. The forward or opposite end of the brace F is provided with a pivoted clip or bow, G, which receives and fits down over the handle or side piece A into a socket or recess, *g*, therein to detachably secure the said brace in place thereon.

By means of this combination and construction of parts the use of nuts, which, when rusted by the weather, become difficult to remove, &c., is dispensed with, the separation of the parts of the saw-frame facilitated, simplicity and lightness of construction obtained, and convenience in handling the saw promoted. The upper ends of the pieces A B may be united by a rope, H, twisted in the old way with an inserted piece or stay, *h*, or otherwise, as desired.

Having thus described my invention, what I claim, and desire to secure by Letters Patent, is—

The combination of the brace F, having the pivoted bow or clip G, side pieces A B, socket *f*, horizontal bar D, having the stud or pin E, and twisted rope H and lever *h*, or their equivalents, when constructed to operate as and for the purpose set forth.

In testimony whereof I have hereunto signed my name in presence of two subscribing witnesses.

WM. HANKIN.

Witnesses:

GUSTAV SMITH,
EMANUEL HOLLAND.