

W. H. PENNISTON. Hay-Press.

No. 164,476.

Patented June 15, 1875.

Fig: 1.

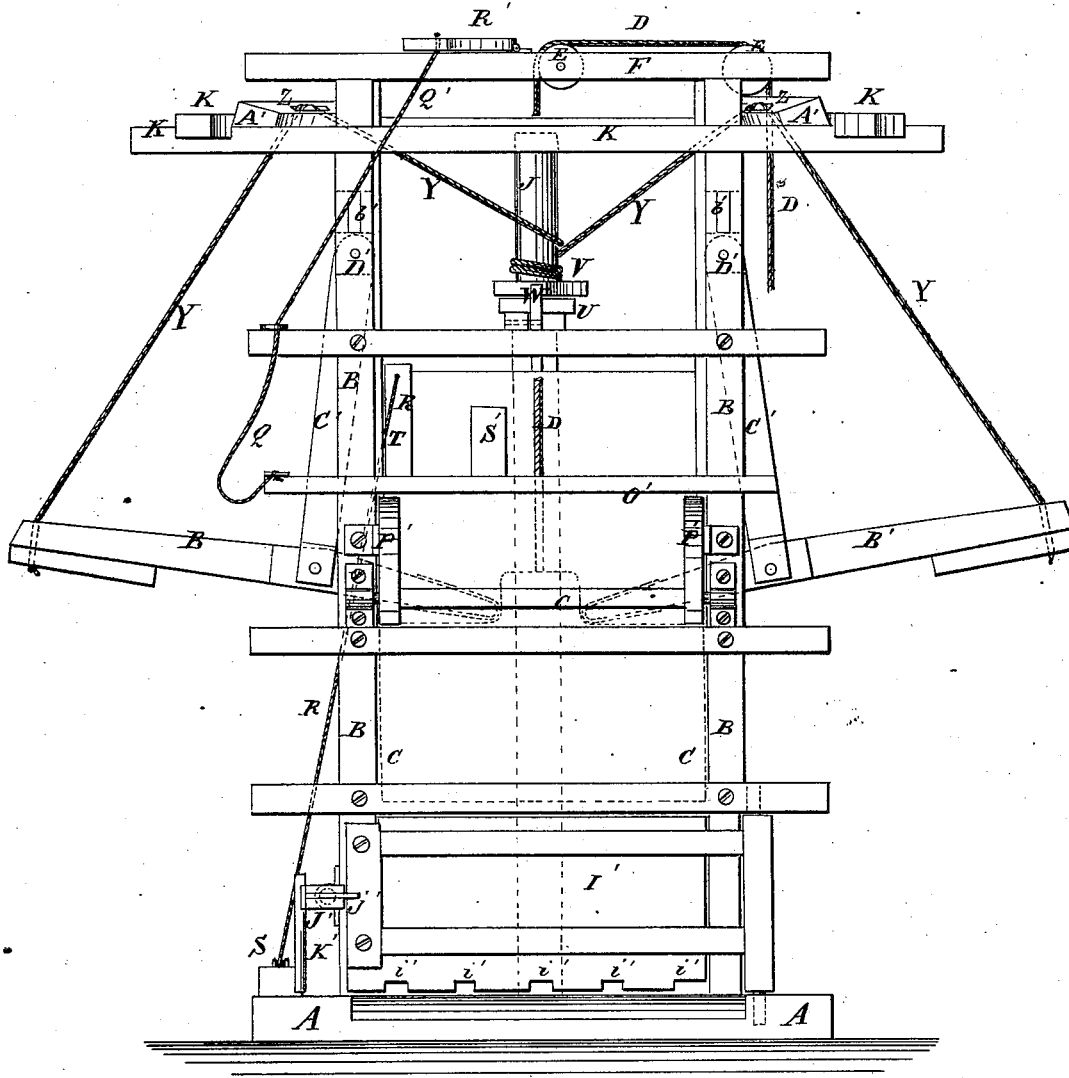
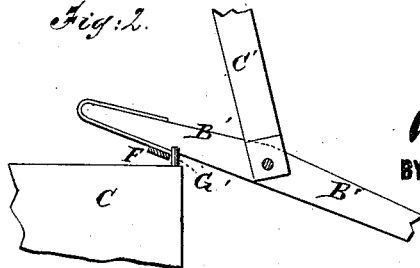

Fig: 2.



WITNESSES:

Chas. Nida
A. H. Terry

INVENTOR:

Wm H. Penniston

BY

[Signature]
ATTORNEYS.

W. H. PENNISTON. Hay-Press.

No. 164,476

Patented June 15, 1875.
Fig. 3.

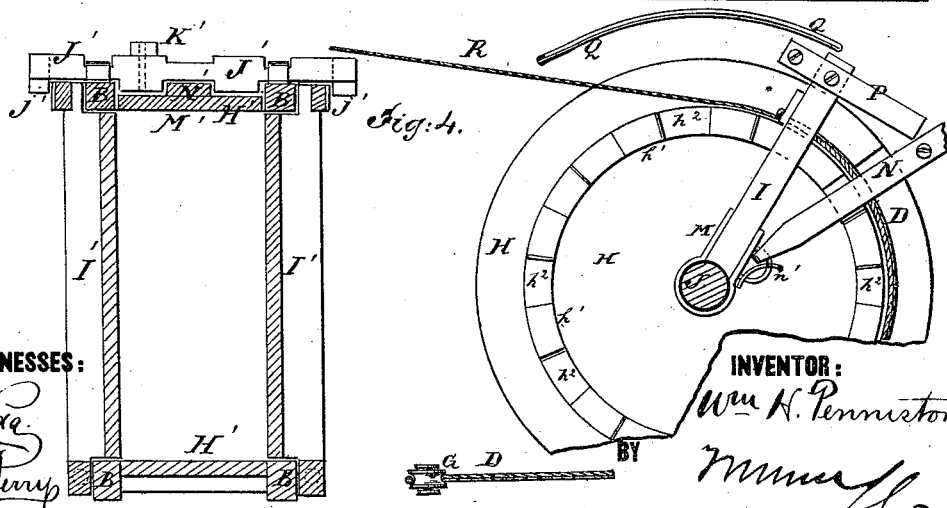
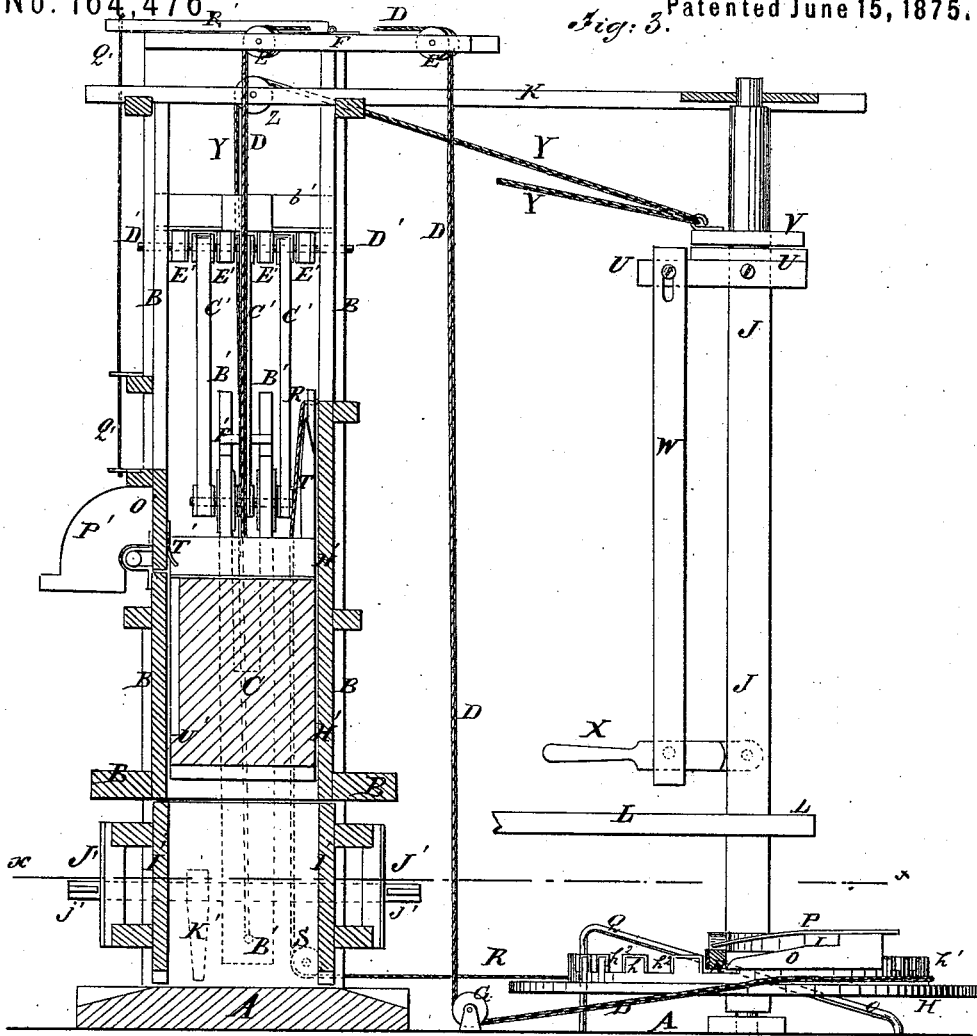

WITNESSES:
Chas. Nida
A. J. Perry

INVENTOR:
Wm. H. Penniston
 BY *[Signature]*
 ATTORNEYS.

UNITED STATES PATENT OFFICE.

WILLIAM HENRY PENNISTON, OF FOX, MISSOURI.

IMPROVEMENT IN HAY-PRESSES.

Specification forming part of Letters Patent No. **164,476**, dated June 15, 1875; application filed March 20, 1875.

To all whom it may concern:

Be it known that I, WILLIAM HENRY PENNISTON, of Fox, in the county of Ray and State of Missouri, have invented a new and useful Improvement in Hay-Presses, of which the following is a specification:

Figure 1, Sheet 1, is a front view of my improved press. Fig. 2, Sheet 1, is a detail view, showing the device for connecting the levers and follower. Fig. 3, Sheet 2, is a vertical section of the same. Fig. 4, Sheet 2, is a horizontal section of the same, taken through the line *x x*, Fig. 2.

Similar letters of reference indicate corresponding parts.

The invention will first be fully described, and then pointed out in the claims.

A represents the base-frame or platform of the press. B is the press-frame. C is the beater, which moves up and down upon ways in the frame B. The beater C is raised by the rope D, one end of which is attached to said beater. The rope D passes over guide-pulleys E, pivoted to a beam, F, attached to the top of the frame, or to some other convenient support, descends near one corner of the frame B, passes around a guide-pulley, G, pivoted to the base-frame A, passes around the rim of the wheel or drum H, and is secured to the outer part of the arm I. The wheel H is rigidly attached to the sweep-shaft or capstan J, the lower end of which revolves in a step attached to the base-frame A, and its upper end revolves in bearings in a frame, K, attached to the upper part of the frame B, or other convenient support. L is the sweep, to which the horse is attached, and which is rigidly attached to the shaft J. The inner end of the arm I is connected to the shaft J by a strap or collar, M, so that the said shaft and arm may move independent of each other. To the rear side of the inner part of the arm I is pivoted a second arm, N, which is provided with a stop, *n'*, to prevent it from being thrown too far from the arm I. The wheel H is provided with an upwardly-projecting ring-flange, *h'*, in which are formed a number of notches, *h''*, into which the arm N may drop, so that the wheel H may carry the arm N with it in its revolution. The arm N, when in one of the notches *h''*, rests against the end of the projection or arm O,

rigidly attached to the arm I, and the upper side of the outer end of which is beveled off, so that the arm N, when in a notch, *h''*, may carry the arm I with it, and when raised out of said notch may slide forward upon the projection O, and be carried by and with said arm I. The arm N is kept from rising upward when upon the projection O by a stop, P, attached to the arm I or projection O. The arm N is raised out of the notch *h''* in the flange *h'* of the wheel H by an incline, Q, attached to the base-frame A, in proper position to raise the arm N out of its notch when the beater C has been raised to the proper height. The arm I is provided with a projection or friction-roller, which rests upon the upper side of the wheel H, and prevents the arm I from catching in the notches *h''*. To the outer part of the arm I is attached the end of the cord R, which passes around the rim of the wheel H, around a guide-pulley, S, pivoted to the base-frame A, and its other end is attached to the end of an upwardly-projecting arm, T, attached to the beater C.

By this construction, as the arms I N are tripped by the incline Q the beater C drops, and the rope D draws the arms I N back. As the beater C reaches the end of its descent, the cord R stops the rearward movement of the arm I, so that the horse will not have to travel uselessly to wind up the slack of the rope D before the beater C begins to rise. As the arm I is stopped, the momentum of the arm N carries it off the projection O until stopped by the stop *n'*, the arm N being left resting upon the flange *h'* of the wheel H, ready to drop into the next notch *h''* that reaches it.

As thus far described, the construction is the same as that described in Letters Patent No. 155,671.

Upon the upper part of the shaft J is formed, or to it is attached, a shoulder or stationary collar, U, upon which rests a collar, V, which turns freely upon the said shaft J. The movable collar V is made square, or of such other shape that it may be caught and held by the upper end of the bar W, which is placed parallel with the shaft J, and slides up and down upon a guide attached to or formed upon the stationary collar U. The lower end of the bar

W is pivoted to the lever X, the inner end of which is pivoted to the shaft J. The lever X is placed above and parallel with the sweep L, so that it may be out of the way, and so that it may be conveniently reached by the driver, and operated to clutch and release the movable collar V. To the movable collar V are attached the ends of two ropes, Y. The ropes Y pass around guide-pulleys Z, pivoted to bars A', attached to the frame K at the edges of the upper part of the press-frame B. The other ends of the ropes Y are attached to the outer ends of the long levers B B'. The levers B' are made double, or are slotted longitudinally from their inner ends, and are pivoted near their inner ends to and between the lower ends of three bars, C'. The upper ends of the bars C' are pivoted to and between the posts of the frame B by a long pin or bolt, D'. The upper ends of the pivoted bars C' are rounded off, and rest against the lower side of a cross-bar, b', of the frame B, so that the pins or bolts D' may be relieved from having to support the whole strain when applying pressure to the beater C. The lower side of the cross-bar b' is faced with metal, to prevent wear and diminish friction. The upper ends of the bars C' are kept at the proper distance from each other and from the posts of the frame B by blocks E', interposed between them, as shown in Fig. 2, and through which the pins or bolts D' pass. To the lower side of the levers B', near their inner ends, are attached small cross-bars F, to catch upon pins G', attached to the end parts of the upper side of the beater C, so that the levers B' may begin to act upon the beater C while the said beater C is above the level of the pivoting-points of the said levers B'. The lower part of the frame B is encased, to form a baling-box, H', the lower parts of the sides of which are formed by the doors I'. The doors I' are hinged at one end, and their other ends are secured, when closed, by projections or shoulders j formed upon the end parts of the shaft J', which works in bearings attached to the posts of the frame B, and which is provided with a lever, K', attached to its middle part for convenience in operating it. The lower part M' of one end of the baling-box H' is left loose, and is held in place by the beveled middle part of the locking-shaft J, which presses against an inclined bar, N', attached to the said movable part M'.

By this construction, when the doors I' are

unfastened to remove the bale, the same operation releases the part M' of the baling-box H', so that the bale, being released from both side and end pressure, may be easily removed.

The upper forward part of the baling-box H' may be provided with a door, O', hinged at its lower edge, so that it may be turned down outward to facilitate the insertion of the material.

To the frame B, at the ends of the door O', are attached guard-boards P', to prevent the material from scattering while being inserted in the baling-box. To the outer edge of the door O' is attached the lower end of the cord Q', the upper end of which is attached to the forward end of the bar R', which rests upon the upper front cross-bar of the frame B, and the rear end of which is hinged to the upper rear cross-bar of said frame B. To the beater C is attached an upwardly-projecting arm, S', which, as the said beater completes its upward movement, strikes the hinged bar R' and raises it, closing the door O'. To the inner side of the lower part of the door O' is attached a spring, T', the end of which projects sufficiently to be struck by a stop, U', placed in a vertical groove in the forward side of the beater C, so that the said door O' may be opened by the descent of the said beater. The spring T' may be adjusted, if desired, to open the door O' as the beater C ascends. In the lower edges of the doors I' are formed notches w', to receive the bale hoops or bands, so that the said hoops or bands may be inserted before the material is put into the baling-box. By this means, when the material is pressed, the hoops or bands will be embedded in the lower side of the bale, so that they will not require to be wedged only upon one side. This saves an inch or two in the thickness of each bale, and enables them to be packed more compactly.

Having thus described my invention, I claim as new and desire to secure by Letters Patent—

A hay-press provided with loose baling-box H', supported by shaft J' and inclined bar N', as shown and described, for the purpose specified.

WILLIAM HENRY PENNISTON.

Witnesses:

JAMES H. BELT,
WM. PENNISTON.