

W. H. HOFFMAN.

Mechanism for Adjusting Lathe-Beds to Different Heights.

No. 164,560.

Patented June 15, 1875.

Fig. 1.

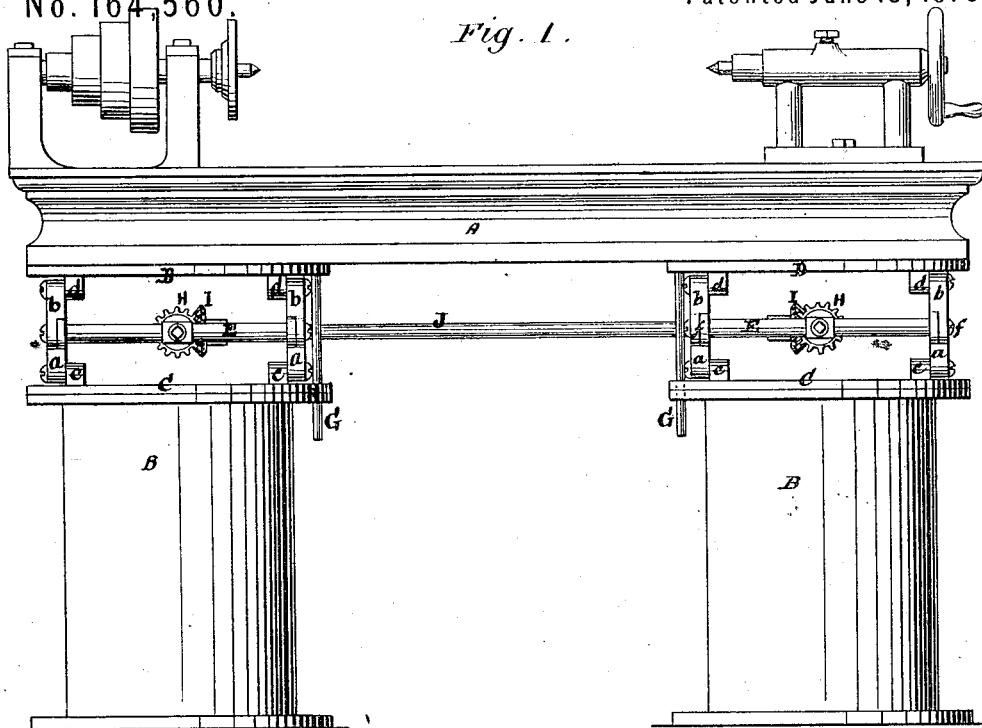
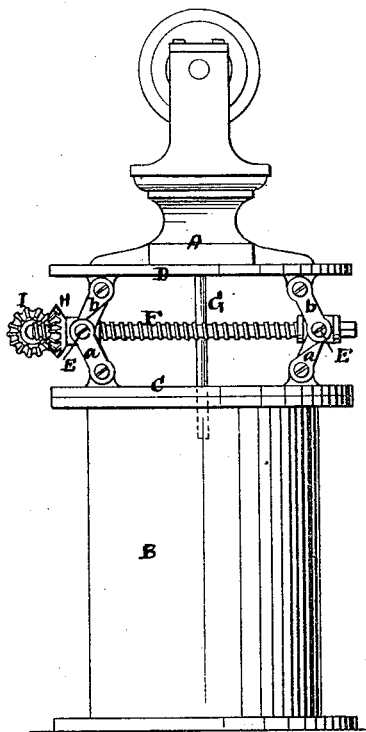

Fig. 2.



Witnesses:

Ewell A. Sick,  
Richard W. Hartnett

Inventor:

Wm. H. Hoffman  
by atty. Pillsbury & Bailey

# UNITED STATES PATENT OFFICE.

WILLIAM H. HOFFMAN, OF PASSAIC, NEW JERSEY, ASSIGNOR TO NEW YORK STEAM-ENGINE COMPANY, OF NEW YORK, N. Y.

## IMPROVEMENT IN MECHANISMS FOR ADJUSTING LATHE-BEDS TO DIFFERENT HEIGHTS.

Specification forming part of Letters Patent No. **164,560**, dated June 15, 1875; application filed March 4, 1875.

*To all whom it may concern:*

Be it known that I, WILLIAM H. HOFFMAN, of Passaic, New Jersey, have invented certain new and useful Improvements in Mechanism for the Vertical Adjustment to Different Heights of the Beds of Engine Lathes and other Machinery, of which the following is a specification:

The object of my invention is to provide a means for vertical adjustment of the beds or tables of engine-lathes and other machinery. This adjustment is advantageous, admitting of bringing the table or bed to different heights, as required by the nature of the work, or for the convenience of the workman. By it, also, any slack in the driving-belts may be compensated for or taken up without the trouble of cutting and relacing said belts. Another advantage is, that it provides for the lowering of the bed or table in preparing it for shipment, so that the machine will occupy much less space than the ordinary lathe or machine, thus economizing room in transportation.

The nature of my invention and the manner in which the same is or may be carried into effect will be understood by reference to the accompanying drawing, in which—

Figure 1 is a side elevation of an engine-lathe made in accordance with my invention. Fig. 2 is an end elevation of the same, only so much of the lathe being shown as is needed to illustrate my invention.

A is the bed of the lathe. B are the supporting-standards. Between each standard or base and the bed are two sets or pairs of knuckle-jointed levers. Each lower arm *a* is pivoted to a lug, *c*, on the top of the standard, or on a plate, C, thereon, and each upper arm *b* is pivoted to a lug, *d*, on a plate, D, fixed to the under side of the lathe-bed. The two arms *a b* of each lever are jointed together at *f*. The two levers on each side of the machine are connected by a rod or bar, E, which is in line with their axes *f*, and, in fact, constitutes the axis upon which the contiguous ends of the arms of each lever move. Through the two bars or rods E of the op-

posite pairs of the levers passes a screw-shaft, F. One end of the screw-shaft is without a screw-thread, and is mounted in a cylindrical bearing in one of the connecting-rods, E, where it is prevented from end play by collars fixed to it on each side of the box or bearing. The other end of said screw-shaft F screws through a screw-threaded bearing in the other connecting bar or rod E. By rotating, therefore, the screw-shaft, the knuckle-jointed levers will be brought nearer together or farther apart, according to the direction in which the shaft is revolved, thus effecting a corresponding elevation or depression of the engine-bed.

One or more perpendicular guide-rods, G, depending from the under side of the bed, or the plate D, and passing through guide-holes in the standard or lower plate C, serve to assure the bed at all times in proper position with respect to the adjusting mechanism. The adjusting mechanism carried by each standard and support B is the same as the other.

For convenience' sake, and in order to operate both sets of adjusting devices simultaneously, I mount on the outer ends of the screw-threaded bearings of the adjusting screw-shafts on one side of the machine, beveled pinions H, encircling and rotated by the said screw-shafts, and meshing with like pinions, I, on the longitudinal shaft J, which is supported and turns in bearings attached to bars E, and will, consequently, rise and fall with said bars.

The rotation of either screw-shaft will, through the medium of the shaft J and gearing H I, cause the simultaneous movement of the other.

It will be understood that the levers rest below on any suitable support, whether that support be standards, as in the present case, or the floor, in case no standards are used.

Having described my invention, and the manner in which the same is or may be carried into effect, what I claim, and desire to secure by Letters Patent, is—

The combination, with the bed or table of an

engine-lathe or other machinery, of knuckle-jointed levers, interposed between the bed and the support upon which it rests, connected together in pairs or sets by screw adjusting-shafts, by which the said levers are operated to effect the lifting or lowering of the machine-bed, as the case may be, substantially as set forth.

In testimony whereof I have hereunto signed my name this 1st day of March, A. D. 1875.

WM. H. HOFFMAN.

Witnesses:

JOHN DUFFUS,  
ALFRED A. ECKERSON.