

W. W. LAING.

Machine for Making Eaves-Troughs.

No. 164,567.

Patented June 15, 1875.

Fig. 1.

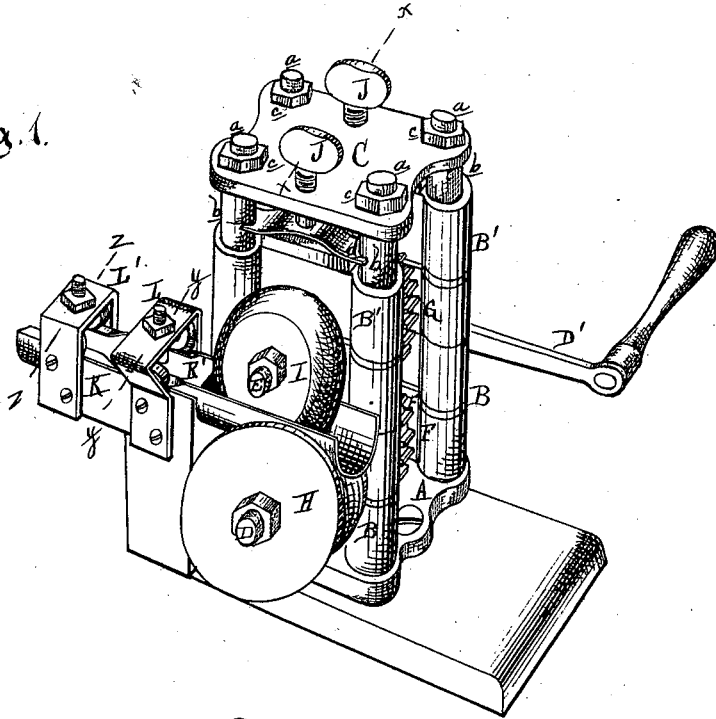

Fig. 2.

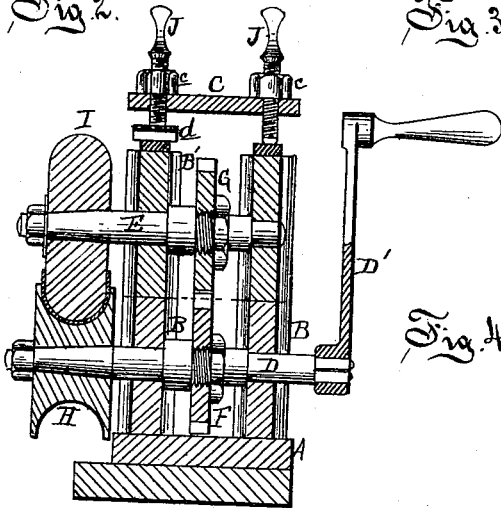

Fig. 3.

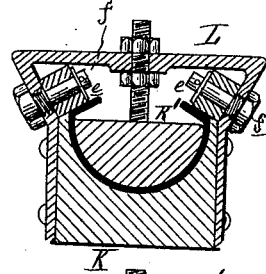
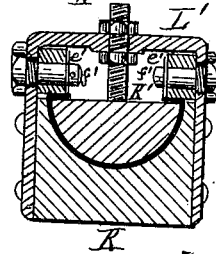

Fig. 4.



Attest:  
Edward Parke.  
James Ormer

Inventor:  
W. W. Laing  
By Attest  
H. S. Sprague.

# UNITED STATES PATENT OFFICE.

WALTER W. LAING, OF HOLLY, MICHIGAN.

## IMPROVEMENT IN MACHINES FOR MAKING EAVES-TROUGHS.

Specification forming part of Letters Patent No. **164,567**, dated June 15, 1875; application filed April 27, 1875.

*To all whom it may concern:*

Be it known that I, WALTER W. LAING, of Holly, in the county of Oakland and State of Michigan, have invented an Improved Machine for Forming Eaves-Trough, of which the following is a specification:

My invention has for its object to furnish a machine for tinner's use, by means of which sheet-metal eaves-troughs can be quickly formed of any length or shape, either from long strips in a single piece, or from strips made by soldering sheets together.

The invention consists in the combination, with a pair of shaping-rolls geared together, of one or more pairs of rolls for turning the edges, and a block and channel-guide for keeping the trough in shape while passing through the machine.

Figure 1 is a perspective view. Fig. 2 is a vertical transverse section at *x x*. Fig. 3 is a cross-section at *y y*. Fig. 4 is a cross-section at *z z*.

In the drawing, A represents the bed-plate of the machine, which can be bolted to a bench, or to a base-board, as shown. B B' are two pairs of superposed boxes, up through whose hollow ends, and the corners of a cap-plate, C, bolts *a*, rising from the corners of the bed-plate, pass. A collar or sleeve, *b*, is interposed between the caps of the top boxes B' and the cap-plate. A nut, *c*, at the top of each bolt, binds the whole together. Through the lower boxes a shaft, D, is journaled, with a crank, D', on one end. Through the upper pair of boxes a shaft, E, is journaled. These shafts are geared together by spur-gears F G. On the end of the shaft D a concave roll, H, is secured by a nut. On the end of the shaft E a round-edged roll, I, is in like manner secured. These rolls, of the section shown, are intended to form half-round gutter or eaves troughs, by passing sheet-metal strips into them while they are rotated by the crank and gearing.

It is evident, however, that rolls of any other section may be substituted therefor which will shape the strip to any form desired.

The caps of the upper boxes are arranged to slide upon the sleeves *b*, and they may be adjusted to lift for any thickness of metal passing between the rolls by temper-screws J J

tapped through the cap-plate. The cap nearest the top-roll has a strong leaf-spring, *d*, interposed between it and the temper-screw, which spring will yield to an increase of pressure, as when a seam is passing between the rolls. K is a concave trough erected on the bed-plate in line with and on the plane of the top of the lower roll, and to its sides two transverse yokes, L L', are bolted. K' is a semi-cylindrical forming-block supported in the trough K by two bolts tapped through the tops of the yokes. By means of the screws it may be adjusted so as to permit the eaves-trough to pass between it and the forming-trough below, while it will also keep the eaves-trough from buckling out of shape. The edges of the concaved strip project vertically above those of the block until the yoke L is reached, when they pass under a roller, *e*, mounted on an inclined stud, *f*, projecting from the side of said yoke, which rollers turn the edges inwardly, as seen in Fig. 3. *e'* are similar rollers, in like manner journaled on studs *f'* projecting horizontally inward from the sides of the yoke L', which rollers turn the flanges flat down upon the block as they pass under said yoke.

The block and its trough must necessarily be of the same section as the rolls, and the rollers *e e'* may be adjusted to turn the flanges inwardly or outwardly, as desired.

As sheet-tin is procurable in strips or rolls of any length desired, up to two hundred feet in length, it is practicable with this machine to make a seamless eaves-trough of any length required as fast as it can be run through the machine. Such a trough will cost much less than a seamed trough, and will be much more durable.

What I claim as my invention is—

In a machine for forming eaves-trough, substantially as herein described, the combination of the forming-rolls geared together, the guide-trough and block, and one or more pairs of rollers for flanging the edges of the eaves-trough, substantially as described.

WALTER W. LAING.

Witnesses:

M. M. BURNHAM,  
DELOS K. BURNHAM.