

J. H. SWASEY.
 Recumbent Chair.

No. 164,607.

Patented June 15, 1875.

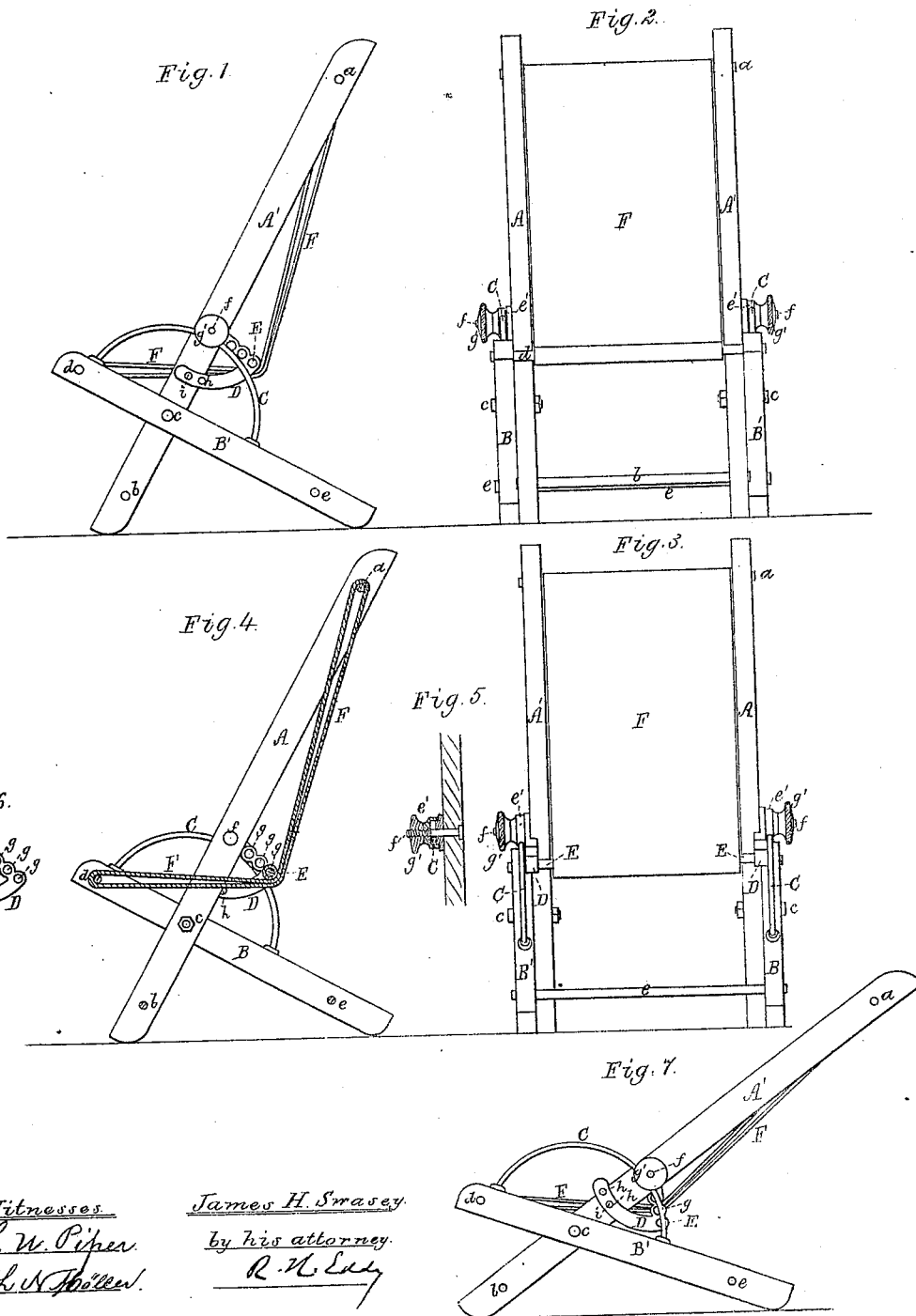

Witnesses
 S. W. Piper.
 L. N. Bowen.

James H. Swasey
 by his attorney
 R. M. Ledy

UNITED STATES PATENT OFFICE.

JAMES H. SWASEY, OF WALTHAM, MASSACHUSETTS.

IMPROVEMENT IN RECUMBENT CHAIRS.

Specification forming part of Letters Patent No. 164,607, dated June 15, 1875; application filed April 29, 1875.

To all whom it may concern:

Be it known that I, JAMES H. SWASEY, of Waltham, of the county of Middlesex and State of Massachusetts, have invented a new and useful or Improved Recumbent Chair; and do hereby declare the same to be fully described in the following specification and represented in the accompanying drawings, of which—

Figure 1 is a side elevation, Fig. 2 a front view, Fig. 3 a rear elevation, and Fig. 4 a vertical section, of a chair of my new or improved construction, consisting of a flexible seat and back piece, two sets of bars, a rod, two perforated sectoral arms, two arched rods, and clamping devices, all arranged, constructed, and combined substantially as hereinafter described.

In such drawings, A A' are two long bars arranged parallel to each other, and connected near their upper and lower ends by two rungs, *a b*. To each of the said bars on its outer side one of a pair of shorter bars, B B', is pivoted, all such bars being arranged as represented, and their pivots being shown at *c c*. The lesser bars B B' parallel to each other are connected by other rungs *d e*. Furthermore, there is fixed to each of the bars B B', at its ends, a rod, C, bent in the form of a semicircular arc, and going through a bell-shaped clamping-washer, *e'*, arranged upon a clamp-screw, *f*, projecting from the next adjacent of the two bars A A', and provided with a screw-nut, *g'*.

Fig. 5 is a section of the clamping devices, taken through and in line with the axis of the screw.

Furthermore, there is arranged to turn upon the shank of each clamp-screw a sectoral arm, D, shaped as shown in side view in Fig. 6, it being provided with a series of holes, *g g*, through its radial or straight part, and another, *h h*, through its curved arc, all as represented. These latter holes are to receive a stud, *i*, projecting from the next adjacent bar A A'. The holes *g* of the sectoral arms D are

to serve as supports for a rod, E, which may be covered with plush or other proper material, which extends from one sectoral arm to the other, such rod being adjusted in the holes nearer to or farther from the centers of the sectoral arms, as occasion may require. An endless apron or flexible back and seat piece, F, is extended around or fastened to the upper rungs of the two sets of bars A A' B B' and underneath the rod or roller E, all as represented. The arcs of the sectoral arms serve as braces to the radial portions of said arms.

By means of the perforated sectoral arms the supporting roller or rod E may be adjusted to different distances from the bars A A', as may be required to vary the positions of the back relatively to the seat of the chair, such back and seat being formed by the endless apron or back piece. As the rod E may be set nearer to the bars A A', they may be moved farther down, so as to bring the back to a greater obtuse angle with the seat; and the back and seat may be tightened by setting backward the bars A A', and be loosened by raising them forward, they being afterward fixed in the necessary positions by the arched rods, and the clamping washers, screws, and nuts.

In Fig. 1 the chair is shown with its back at, or about at, its highest inclination for a setter, while Fig. 7 shows it as depressed to its lowest inclination or to a recumbent position.

I claim—

The recumbent chair, substantially as described, composed of the flexible apron or seat and back-piece F, two sets of bars, A A' B B', rod E, perforated sectoral arms D D, arched rods C C, and their clamping screws or devices *e' f g'*, all arranged, connected, and combined essentially as explained and represented.

JAMES H. SWASEY.

Witnesses:

R. H. EDDY,
J. R. SNOW.