

T. B. ATTERBURY. Glass Annealing Oven.

No. 164,632.

Patented June 22, 1875.

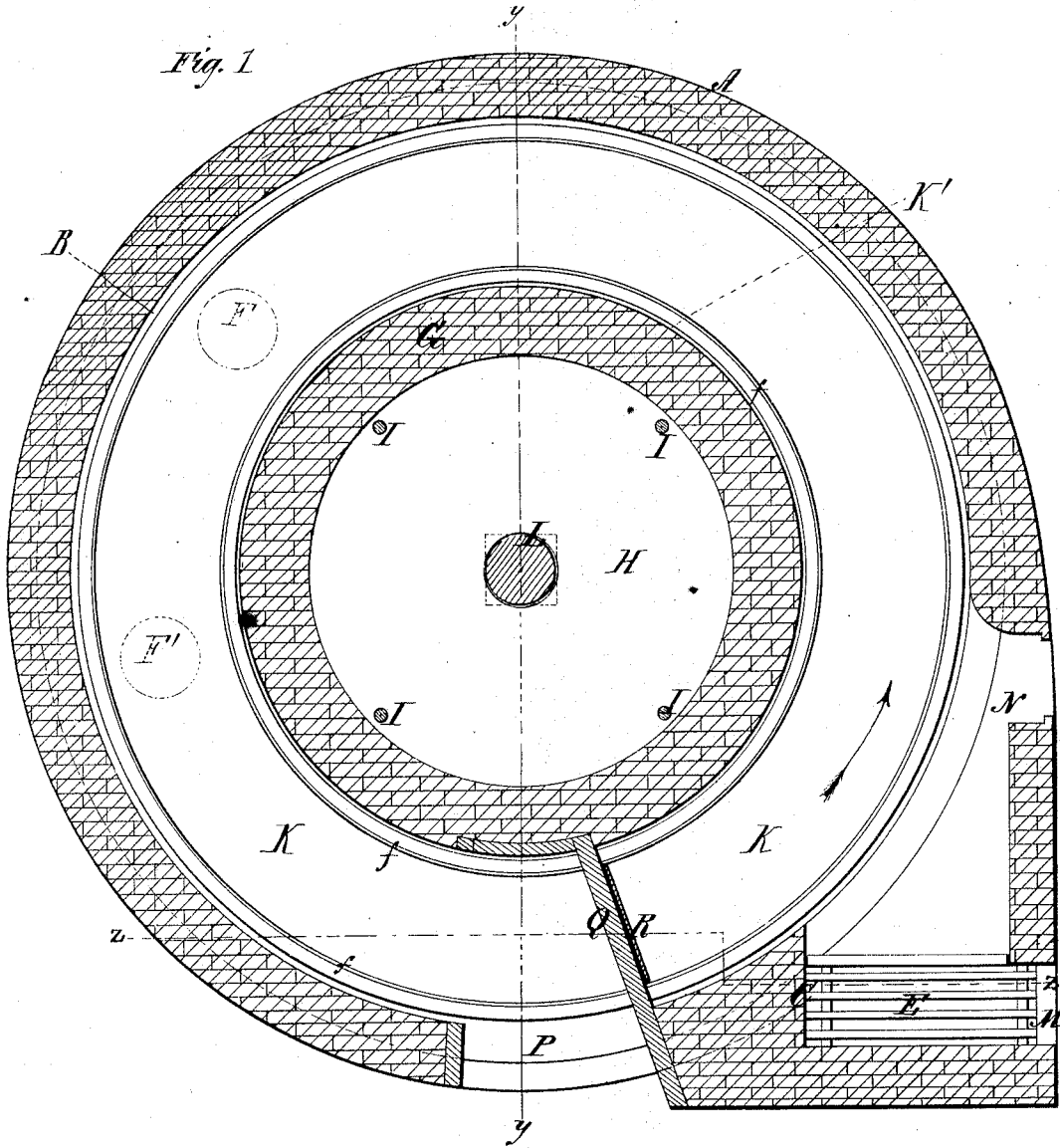

Fig. 1

Witnesses:
James Martin
J. V. Campbell

Inventor:
Thomas B. Atterbury
by:
Messrs. Fenwick & Lawrence

T. B. ATTERBURY. Glass Annealing Oven.

No. 164,632.

Patented June 22, 1875.

Fig. 2.

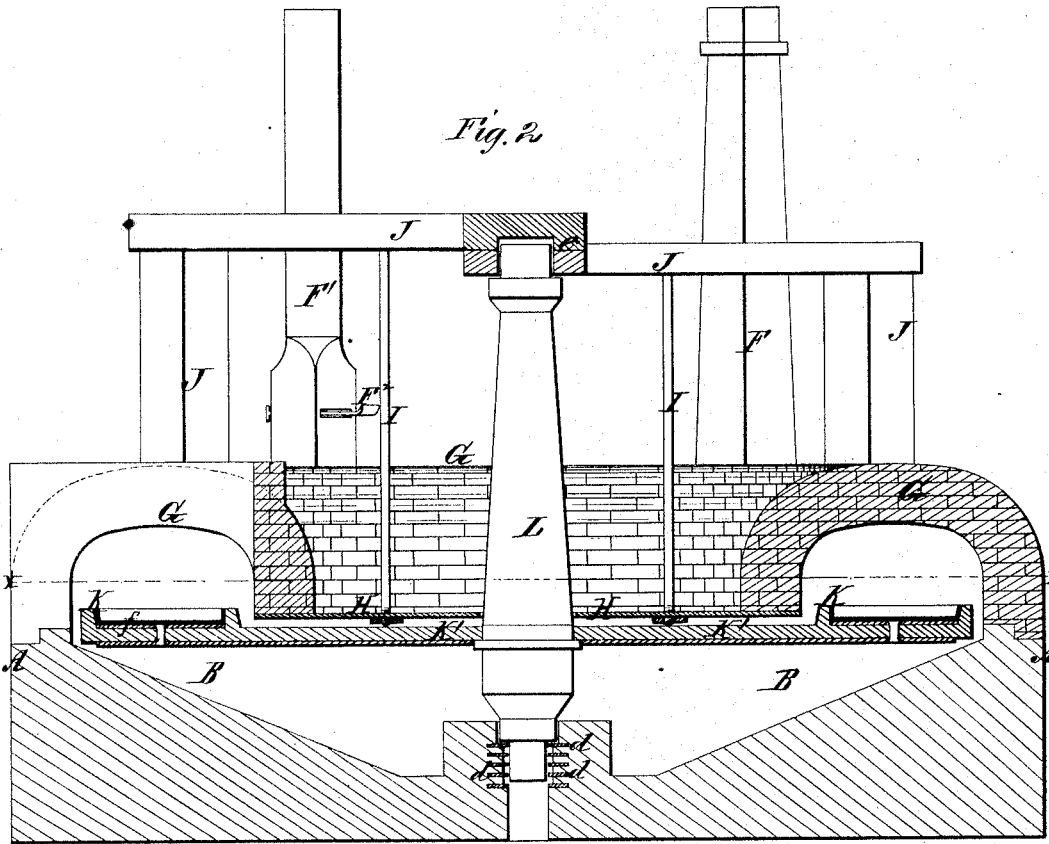
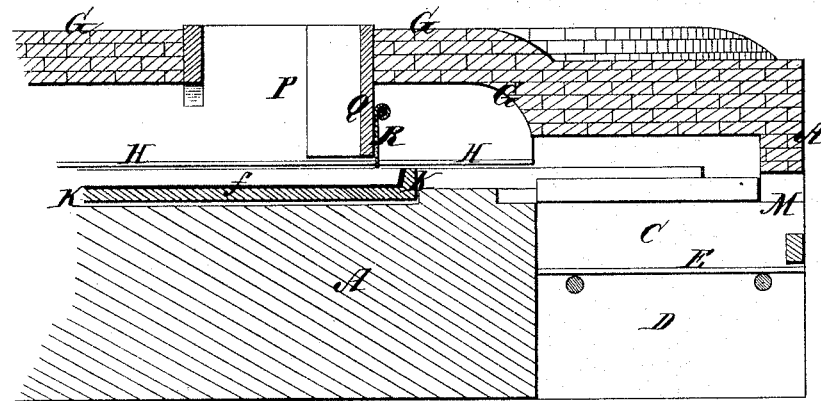

Fig. 3.



Witnesses.
James Martin Jr.
E. N. Campbell

Inventor.
Thomas B. Atterbury.
 by
Mason, Fenwick & Lawrence.

UNITED STATES PATENT OFFICE.

THOMAS B. ATTERBURY, OF PITTSBURG, PENNSYLVANIA, ASSIGNOR OF ONE-HALF HIS RIGHT TO JAMES S. ATTERBURY, OF SAME PLACE.

IMPROVEMENT IN GLASS-ANNEALING OVENS.

Specification forming part of Letters Patent No. **164,632**, dated June 22, 1875; application filed May 24, 1875.

To all whom it may concern:

Be it known that I, THOMAS B. ATTERBURY, of Pittsburg, county of Allegheny and State of Pennsylvania, have invented an Improved Glass-Annealing Oven; and I do hereby declare that the following is a full, clear, and exact description thereof, reference being had to the accompanying drawings making part of this specification, in which—

Figure 1 is a horizontal section in the line $x x$ of Fig. 2. Fig. 2 is a vertical section in the line $y y$ of Fig. 1. Fig. 3 is a vertical section in the line $z z$ of Fig. 1.

Similar letters of reference indicate corresponding parts in the several figures.

The nature of my invention consists in certain constructions and combinations of parts, as hereinafter described and specifically claimed, whereby the labor of operating the glass-carrying pan or table is greatly facilitated, the danger of the parts of the oven warping by intense heat avoided, and the loss of heat and imperfections in the annealing process are prevented.

A is a brick wall, surrounding a chamber, B. At one corner of this wall a fire-chamber, C, an ash-pit, D, and a grate, E, are constructed. The chamber B is in communication with two draft-chimneys, F and F¹. The draft-chimney F¹ is provided with a damper, F², which is opened and closed, as occasion may require. When the damper F² is closed the chimney F alone serves for the draft, and carries off all the waste gases and heat; and when the damper is opened the chimney F and F¹ perform this office together. By this arrangement the surplus heat which passes the chimney F escapes through the chimney F¹, and should it be desired to retain this heat the damper is closed, and the said heat compelled to pass off through the chimney F. The dotted circles in Fig. 1 are intended to indicate the relative positions of these chimneys where they enter the arch in which the glass is annealed. G is an arch, which, in cross-section, is a segment of a circle or ellipse. This arch extends entirely around the wall A, and one side of its base rests upon the edge of said wall, and the other upon a horizontal ring-plate of metal, H. The

metal plate H is suspended by rods I upon a strong frame, J. By this construction a circular arched tunnel, having a funnel-shaped bottom, is formed within the outer wall, and in this tunnel the glass to be annealed is placed. For supporting the glass a circular flanged pan or table, K, is arranged within the circular arched tunnel. This pan has a central hub or web, K', through which a central revolving shaft, L, is passed. The shaft and pan are connected fast to one another so as to revolve together. The lower end of the shaft is shouldered, and extended into a box provided with narrow steel rings $d d$, which serve as bearing and wearing surfaces, and offer but very little friction to the rotation of the shaft; and its upper end is also shouldered and confined in a central box, e , of the frame J, as shown. The pan or table proper K is thickly lined with clay, as at f , in order to husband in this lining portion of the pan a great supply of heat about the bottom portion of glass articles placed therein to be annealed. If the pan were not thus lined the upper portion of tall glass articles—like lamps, bowls, and jars—would become in the process of annealing much hotter at their top than at their bottom, whereas the heat should be uniform throughout. Around the sides of the oven a passage, M, to the fire-chamber, a passage, N, for the introduction of the glass into the pan, and a passage, P, for the withdrawal of the annealed glass, are provided, as shown in the drawings.

In order to direct and diffuse the flame of the fire over the glass upon the pan, a partition-wall, Q, is made across the arched tunnel, between the back of the fire-chamber and the withdrawal-passage P, and at the lower end of this wall a hinged flap gate, R, is suspended, so as to rest down upon the flanged pan proper. The gate rises as the pan passes around under it, and thus, while it does not interfere with the movement of the pan, prevents the entrance of a large volume of cold air upon the glass in the direction of the rotation of the pan. The entrance of cold air would chill and destroy the glass.

The passage for introducing the glass upon the pan is about eight feet from the fire-chamber, in order that a large preparatory heating-

chamber shall be formed, in which the clay-pan is throughly heated before the glass is placed therein.

The pan may be revolved by a cog-wheel on the shaft, L, below the pan, this wheel being geared with a pinion on a shaft located at the point where the glassware is taken from the pan.

In operating with the "lier" or tempering-oven, the pan is turned gradually in the direction indicated by the arrow, and glass is placed upon it, through the passage N, as fast as the placed glass passes beyond this passage. A boy is capable of moving the pan, as the friction is so slight. While the pan is moving, the flame passes in a diffused state in the direction of the arrow, and escapes through the first chimney F, if the damper of the second, F¹, is closed, or through both chimneys, if the damper is open.

My present plan of construction is very simple, and the labor and expense of operating are far less than is experienced with the lier which was patented by us June 28, 1864, No. 43,298; and besides this, we do not have to contend with the warping and twisting of the pans and rails, which caused the parts to work untrue; nor with the friction of so many wheels working on rails.

What I claim is—

1. The circular oven, provided with a fire-chamber and passages for introducing and withdrawing the glassware, and a tunnel within its inner wall, one side of the top of the tunnel resting on a suspended plate, in combina-

tion with a pan fastened to a central revolving shaft, substantially as and for the purposes described.

2. The oven, with the openings for introducing and withdrawing the glass-ware, in combination with the transverse partition Q and the fire-chamber C, substantially as described.

3. The partition, with a space below its edge and a gate hung at its bottom, in combination with the oven, having the form of a circular tunnel, whereby the fire is diffused over the glass, substantially as described.

4. The revolving pan K, having a lining of clay to husband the heat at the bottom of the pan, in the process of annealing glass, substantially as described.

5. The fire-chamber, located in the specified relation to the receiving-passage N', for the purpose of heating the clay-pan preparatory to placing the glass upon the pan, substantially as described.

6. The hinged gate R, for preventing the air passing upon the heated glass in the direction of the motion of the pan, substantially as described.

7. The chimney F¹, in combination with the chimney F and the oven and fire-chamber, substantially as described.

8. The revolving shaft with its pan, substantially as and for the purpose described.

THOS. B. ATTERBURY.

Witnesses:

JNO. P. SCOTT,

WM. J. PATTERSON.