

C. R. TOMPKINS.
Planing-Machine.

No. 164,666.

Patented June 22, 1875.

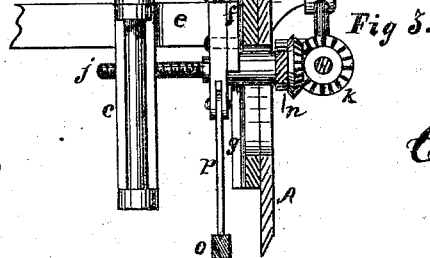
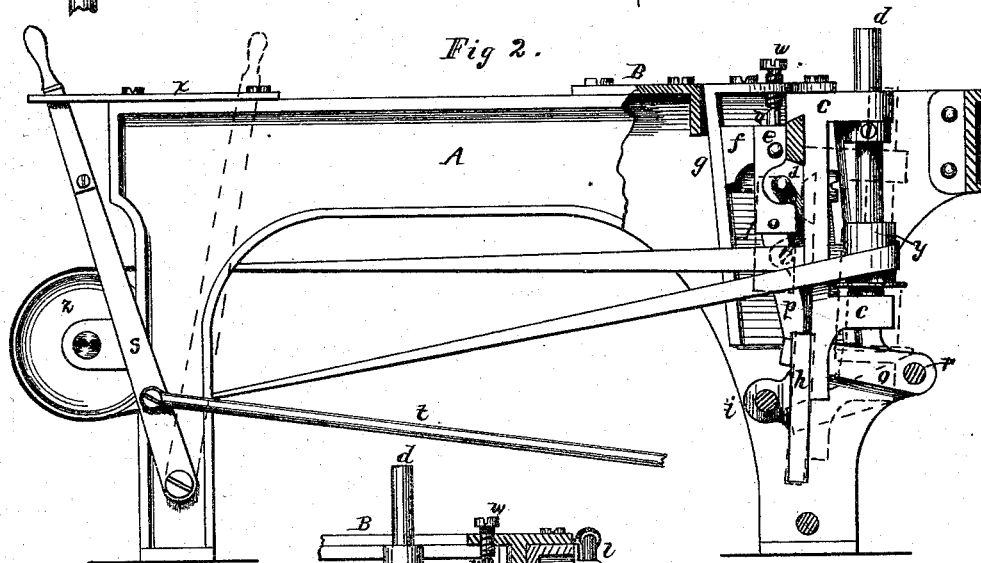
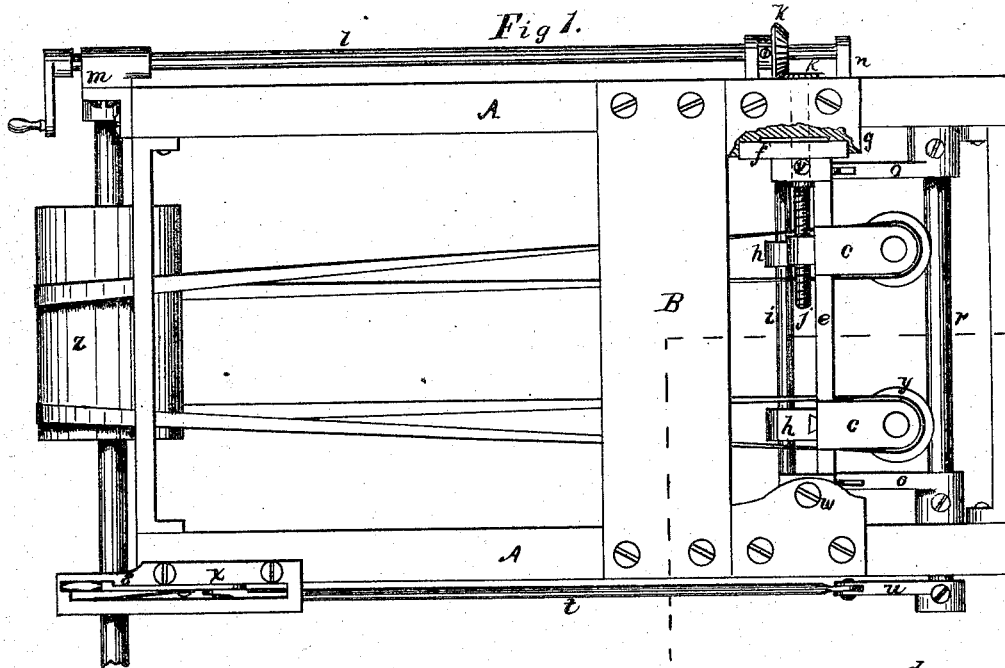

Witnesses:
Henry P. Smith
Thos. Smith

Inventor:
Charles R. Tompkins

UNITED STATES PATENT OFFICE.

CHARLES R. TOMPKINS, OF ROCHESTER, NEW YORK.

IMPROVEMENT IN PLANING-MACHINES.

Specification forming part of Letters Patent No. **164,666**, dated June 22, 1875; application filed April 13, 1875.

To all whom it may concern:

Be it known that I, CHARLES R. TOMPKINS, of the city of Rochester, county of Monroe and State of New York, have invented certain new and useful Improvements in Planing-Machines; and I do declare that the following is a true and accurate description of the same, reference being had to the accompanying drawings and to the letters of reference marked thereon, being a part of this specification.

The object of my invention is to facilitate the changing from a matching-machine to a surfacing-machine, and back again, in that class of machines known as the combined planer and matcher. It is well known to all parties familiar with that class of machines that in order to surface-plane a board the whole width of the planing-cylinder the side cutters or matcher-heads must be got out of the way, and various devices have been invented to accomplish this object, all of which so far have been subject to certain objections, such as delay in stopping the machine, taking off belts, and removing gum and dust at the place of contact, in order to bring the matching-works back again to the exact position that they were in before the change was made. The object of my invention is to remedy these objections and to facilitate these changes.

In the accompanying drawings, Figure 1 is a top view of the machine. Fig. 2 is a side elevation, with the frame broken away to show my improvement. Fig. 3 is a detached vertical section of the same.

Similar letters of reference indicate corresponding parts.

The cylinder, rolls, gearing, &c., being common to all machines of this class, they are omitted in the drawings, and nothing is shown but what is necessary to illustrate and explain my invention.

A is the main frame of an ordinary planing-machine, to which all the working parts are attached. B is the bed-plate, over which the stuff to be worked passes when being planed, before it reaches the matchers *d*, which are of the ordinary kind common to all such machines, and not shown in the drawings. The casting *c*, connecting the upper and lower boxes for the matcher-spindles *d*, is mounted upon a movable bar, *e*, having a

suitable projection on the front side to receive it, and the same is firmly secured to it by means of a dovetailed slide, as seen at C, Fig. 2. At each end of this bar *e*, Fig. 1, is a block or die, *f*, working into the angular slides *g*, and are pivoted to each end of bar *e*, so as to work easily thereon. The lower ends of castings *c* are attached to oscillating boxes *h*, and slide up and down freely upon the face of the same, and are kept firmly attached by means of the dovetailed slides, one of which may be seen in Fig. 1. This box *h* is free to turn upon shaft *i*, or slide along the same lengthwise, whenever necessary to change the width of the matching-spindles *d*, or the distance between them for wide or narrow stuff. Usually one of the matcher-spindles remains stationary at one side of the machine, while the other is varied to suit the different widths of stuff, by means of the screw *j*, gears *k k*, and crank-shaft *l*, shown in Figs. 1 and 3. The crank-shaft *l* passes through the box *m* at the front of the machine, and said box is pivoted to the frame in such a manner as to allow the opposite end that carries the yoke *n* to move up or down with the matching-works without detaching the bevel-gears *k k*. The yoke *n* passes through the main frame, and is attached to the bar *e* by means of a suitable hub, through which the screw passes, thus confining the gears *k k* in their proper position, and keeping them always in gear. This prevents the matching-heads from being changed, or getting out of place when the same are let down for surfacing. Each end of the bar *e* is supported upon the arms *o o* by means of the connections *p*. These arms are firmly attached to the shaft *r*, the ends of which work in suitable bearings attached to the main frame, and connected to the lever *s* by means of the rod *t* and arm *u* outside of the frame, as shown in Fig. 1.

To insure accuracy in its work, and to prevent shavings, dust, and gum from obstructing the bar *e*, so as to prevent its returning to the exact position again after being let down for surfacing, I put at or near each end of said bar a suitable projection, *v*. (Shown in Figs. 2 and 3.) This may be cast on the bar, or a suitable pin inserted therein, and may be either square or pointed; I usually make it

pointed. To receive this point, and make a more perfect contact, I insert another point from above, and this is usually made in the form of a bolt or set-screw, *w*, to facilitate the adjustment of bar *e*, the lower end of which I countersink to receive point *v*, as shown in Fig. 3 at *w* and *v*. These being the only points of contact, there will not be a sufficient quantity of gum or dust adhering to the same to make any perceptible difference when brought again to its proper place.

Another object in pointing *v* and countersinking *w* is, that it not only forms a reliable stop or gage for bar *e*, but it also helps to prevent any tremble or vibration that might occur by wear in the slides *g* or die *f*.

The lever *s* is held in position by the slotted guard *x*, which is fastened to frame A, and can be so set as to always insure perfect contact with *v* and *w*.

The sliding boxes *h*, at the lower end of *e*, have an inclination forward as well as the upper slides *g*, so that when the spindles *d* travel from one point to the other they travel substantially in the arc of a circle, the center of which is the shaft that carries the driving-pulleys *z*, thus keeping the belts in the same relative position, and rendering it unnecessary to take them off when the spindles *d* are let down for surface planing, which is a great saving of time, as such changes require to be frequently made.

The operation is as follows: The lever *s* being drawn back to its proper position, as indicated in Fig. 2, the bar *e*, with its projections *v* and *w*, being firmly in contact, the machine is now in the proper condition for matching. If it is required to surface lumber of any width without altering the position of the matcher-heads with reference to width, the operator takes hold of the lever *s*, and carries it forward to the position indicated by the dotted lines shown in Fig. 2. This acts upon the arm

u by means of the rod *t* and rock-shaft *r*, levers *o o*, and connections *p*. The bar *e* and the whole matching-works slide down to a point far enough below the bed-plate B to allow the lumber that is being planed to pass over the matching-heads, which are attached to the spindles at *d*, the belts retaining the same position upon the pulleys *y*, and the matcher-heads running at the same time. When the surface planing is finished, the operator again takes hold of the lever *s*, draws it back to its former position, when the points of contact *v* and *w* come together, and the machine is now in the exact position for matching that it was before the change was made. The whole time consumed in making both changes need not occupy more than one-half of a minute.

Having described my invention, what I desire to secure by Letters Patent is—

1. The bar *e*, provided with the projecting points *v*, in combination with the adjusting-screws *w*, for regulating the vertical movement of the matcher-heads, substantially as and for the purpose shown and described.

2. The oblique slides *g* and pivoted blocks *f*, in combination with the bar *e*, oscillating slides *h*, and spindle-carriers *c*, substantially as shown and described.

3. The combination and arrangement of the yoke *n*, screw *j*, gears *k k*, shaft *l*, and pivotal box *m*, as and for the purpose specified.

4. The combination, with the bar *e*, carrying the matching cutter-heads of a planing and matching machine, of the rock-shaft *r*, provided with arms *o o*, the arm *u*, rod *t*, and lever *s*, substantially as shown and described, for the purpose set forth.

CHARLES R. TOMPKINS.

Witnesses:

HENRY F. SMITH,
THOS. SMITH.