

F. X. BYERLEY.

Apparatus for Purifying Paraffine, &c.

No. 164,672.

Patented June 22, 1875.

Fig. 1.

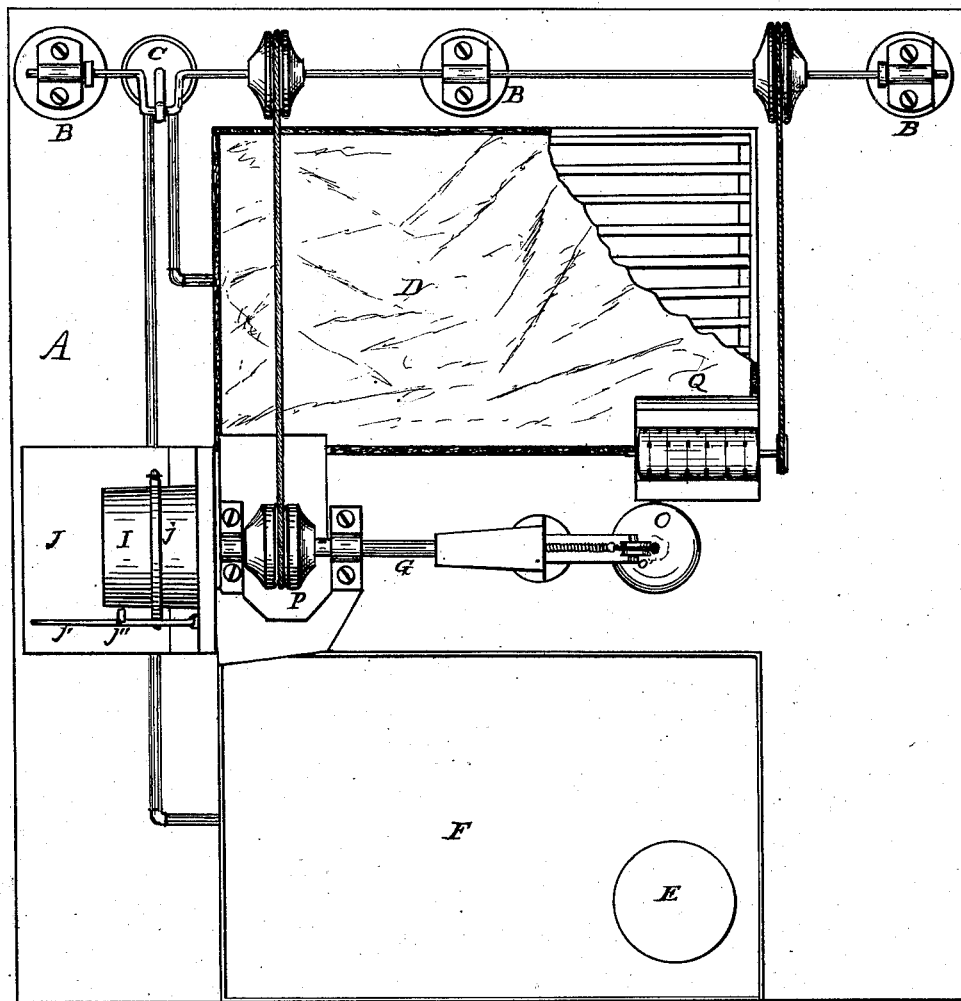

Witnesses:

Geo. H. Tibbitts

W. B. Johnson

Inventor:

F. X. Byerley

F. X. BYERLEY.

Apparatus for Purifying Paraffine, &c.

No. 164,672.

Patented June 22, 1875.

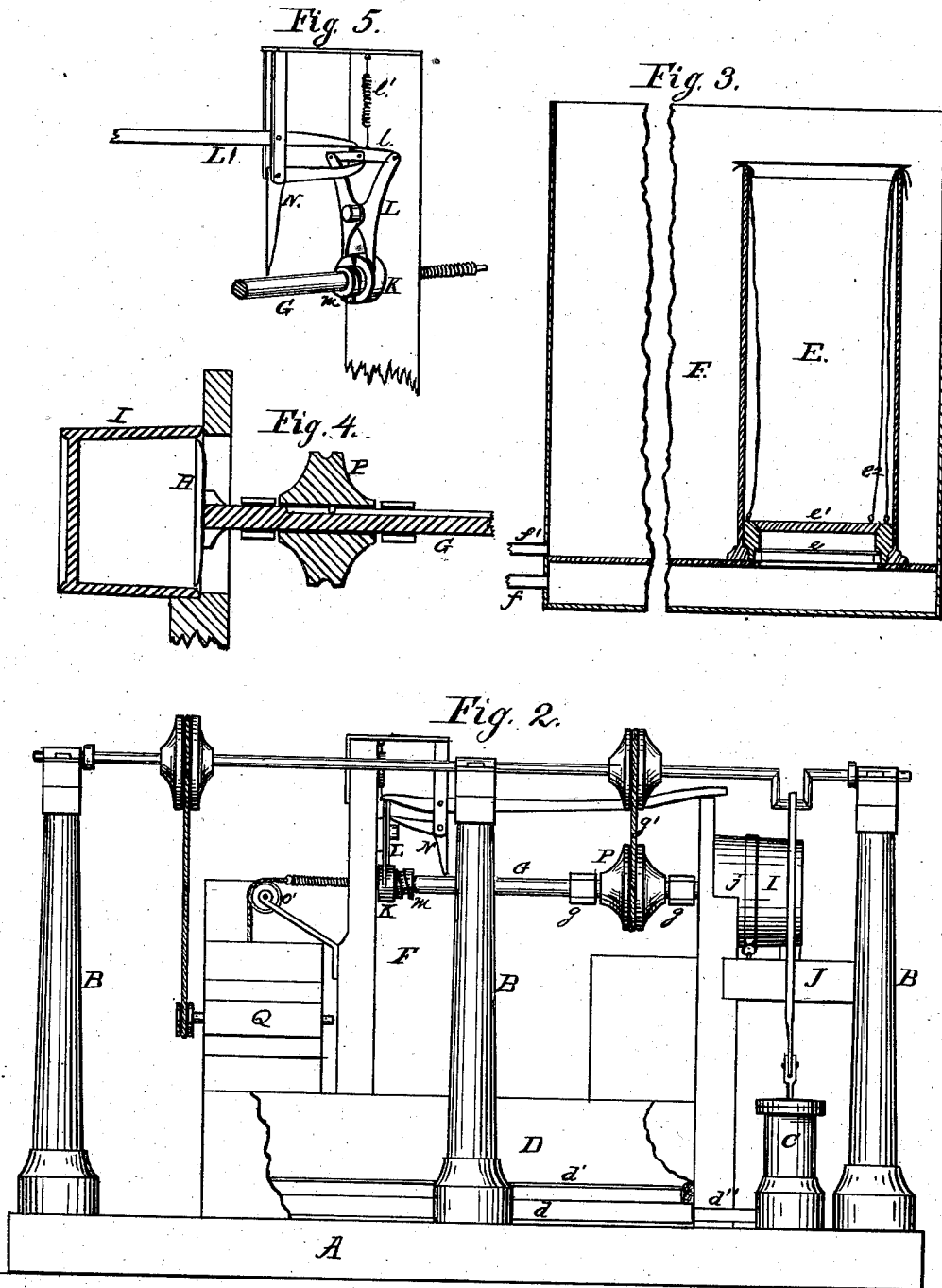

Witnesses:

Geo. W. Pittitt

M. S. Johnson

Inventor:

F. X. Byerley

UNITED STATES PATENT OFFICE.

FRANCIS X. BYERLEY, OF CLEVELAND, OHIO.

IMPROVEMENT IN APPARATUS FOR PURIFYING PARAFFINE, &c.

Specification forming part of Letters Patent No. 164,672, dated June 22, 1875; application filed September 14, 1874.

To all whom it may concern:

Be it known that I, FRANCIS X. BYERLEY, of Cleveland, in the county of Cuyahoga and State of Ohio, have invented an Apparatus for Obtaining and Purifying Paraffine and other crystalline or granular substances, such as stearine, tallow, sugar, &c., of which the following is a specification:

This invention relates to an apparatus for obtaining and purifying crystallizable substances, such as paraffine, stearine, tallow, sugar, &c., and the invention consists of an apparatus for purifying and crystallizing paraffine and the like, wherein the substance is crystallized in closed cylinders by heat or cold, the waste strained off, and the substance then purified with the proper solvents in a receiver having a filter-bottom, as hereinafter fully set forth.

To enable others to fully understand my invention, I will proceed to describe the same in detail, with the aid of the accompanying drawings, in which—

Figure 1, Sheet 1, is a plan view. Fig. 2, Sheet 2, is an end elevation. Fig. 3, Sheet 2, is a vertical section of one of the cooling-cylinders, showing the aforesaid filtering or straining bottom. Fig. 4, Sheet 2, is a detached sectional view of the revolving cutting-knife, tub, and part of the shaft. Fig. 5, Sheet 2, is a detached view of the divided nut and tongs and a portion of the shaft.

A represents the floor upon which the apparatus stands. B are posts for supporting the driving-shaft. In a building this shaft may be supported by hangers or brackets from the ceiling or walls. C is a pump arranged to be operated from said shaft. D is a box or receiver, and is provided with a filtering or straining bottom, consisting of a rack, *d*, covered with a cloth or straining material, *d'*, adapted to the substance to be treated, stretched over the rack and tightly secured at the edges by a packing of oakum or other suitable material, this straining-bottom being placed a little above the true bottom of the box or receiver. This box or receiver D is connected with the pump at a point below the false or straining bottom by the pipe *d''*. E is a graining or crystallizing cylinder or can having a bottom provided with a strainer, *e*,

the bottom also having a cover, *e'*, the said bottom and cover being each fitted into ground seats to render them tight. The cover *e'* is provided with a cord, *e''*, for the purpose of withdrawing the same when required; the bottom also has two cords attached for the purpose of withdrawing it. The cylinder E is placed in a tank or box, F, which may be capable of holding several of them, having a false bottom, there being openings in the said false bottom corresponding to the size of the cans over which the cylinders E are placed and securely and tightly attached to the false bottom. The interstices between the cylinders E in the tank F are to be filled with any substance to regulate the temperatures of the cylinders and their contents so as to promote the best and most effective crystallization or granulation of said contents. The space beneath the false bottom is connected with the pump C by a pipe, *f*. There is an outlet-pipe, *f'*, attached to the tank F above the false bottom to carry off any draining from the material used for regulating the temperature. G is a shaft supported in bearings *g g* and connected by a belt, *g'*, to a pulley on the driving-shaft, from which it derives its motion. On one end of said shaft G is attached a knife, H, which is designed for cutting and removing the crystallized or grained mass from tub I, which is placed on a platform, J, for that purpose, the tub being secured in its place by a band, *j*, and lever *j'* engaging with a catch-piece, *j''*. The opposite end of the shaft G has a screw-thread cut on it, which runs in a divided nut, K, the object of this is to cause the knife to advance into the tub I as fast as the contents are cut away. The divided nut is attached to a pair of tongs, L, the upper ends of the arms of which are connected by a jointed lever, *l*, which holds them apart and closes the nut on the screw. On the shaft G is placed an adjustable worm-screw stop, *m*, which, when the shaft has advanced to the proper point, engages with the pendent arm of a right-angle lever, *n*, the other end of which lifts the jointed lever *l*, which allows the arms of the tongs to approach, opening the nut K, and which is held so by the spring *v*, thus releasing the shaft, which is immediately drawn back by a weight,

O, attached to it by a cord passing over a pulley, O', the cord being attached to the end of the shaft G by a swivel-ring. The shaft where it passes through the pulley P has a groove in which a feather on the inside of the pulley plays. Q is a mill, in which the substance under treatment, if it becomes lumpy after having been treated with solvents in the box or receiver D, may be again broken up. L' is a lever for closing the tongs by bearing on the jointed lever l.

The operation of this apparatus is as follows: The substances to be refined or purified being in an uncrystallized or ungrained state—such as paraffine in the state of paraffinized oil or lard melted—is placed in the cylinders E, the bottoms to the cylinders having been carefully adjusted in their seats and the covers to the bottoms on theirs and the caps put on the cylinders. There is introduced into the tank F in the spaces between the cylinders any substance or combination of substances—such as pounded ice and salt, if cold be required, or steam, if heat be required—that will produce the proper temperature for the contents of the cylinders to grain or crystallize most effectually. When the crystallization or graining has been accomplished the caps of the cylinders are removed, and if necessary the mass inside is stirred or broken with any suitable instrument. The cover *e*¹ to the straining-bottom is then removed. This allows the crystallized mass to come in contact with the strainer. The pump is then set in motion and all the liquid portion of the crystallized or grained mass drawn off and delivered into its proper receptacle, the solid or crystallized portion being retained in the cylinder by the strainer. The purifying could be completed in this apparatus by the addition of the proper solvents, the pump being kept in motion; but usually it will be found advantageous when the mass above the strainer has been drained to a sufficient dryness by the process described to remove it to the box or receiver D, this being of more convenient form for the subsequent process and the cylinders being thus left free for a new charge. The dry mass having been removed from the cylinders E to the box D and spread on the surface of the false bottom, the pump is set

in motion and the proper solvent for the substance under treatment—as gasoline, naphtha, or alcohol, for paraffine, stearine, or tallow, and water for sugar, &c.—is sprinkled over it. The solvents and the parts dissolved are passed through the straining material, the solid being left above the cloth. This sprinkling and pumping are continued till the substance has been purified to the degree desired. When the object is to purify paraffine or stearine, obtained in the usual way, or any substance that is already grained, the use of the tank F and cylinders E can be dispensed with and the substance placed at once in the box D. If it is grained or crystallized in a solid mass it should be cut out of the vessels containing it by the cutting-machine above described. After being placed in the box D the proper solvents are sprinkled upon it and the pump set in motion, the operation being continued until the required degree of purity has been attained. If during the treatment with the solvent the substance under treatment should gather in lumps, the operation of the solvent would be facilitated by passing the material through the mill Q.

I claim—

1. In an apparatus for crystallizing and purifying paraffine and the like, the crystallizing-tank F, provided with a perforated bottom, in combination with straining-cylinders E, provided with removable bottoms, substantially as and for the purpose described.

2. The within-described method of purifying and crystallizing paraffine and the like, consisting in crystallizing the substance in closed cylinders by heat or cold, and straining off the waste, then purifying such crystallized substance in a receiver having a filter-bottom, with the proper solvents, substantially as specified.

3. The shaft G, knife H, divided nut *k*, tongs L, jointed lever *l*, spring *l'*, worm-screw stop *m*, and right angle lever *n*, weight and cord O, and pulley P, all combined, and operating as and for the purpose set forth.

F. X. BYERLEY.

Witnesses:

GEO. W. TIBBITTS,

M. L. SCHERMERHORN.