

H. M. DICK.  
Mail-Bag Catches.

No. 164,677.

Patented June 22, 1875.

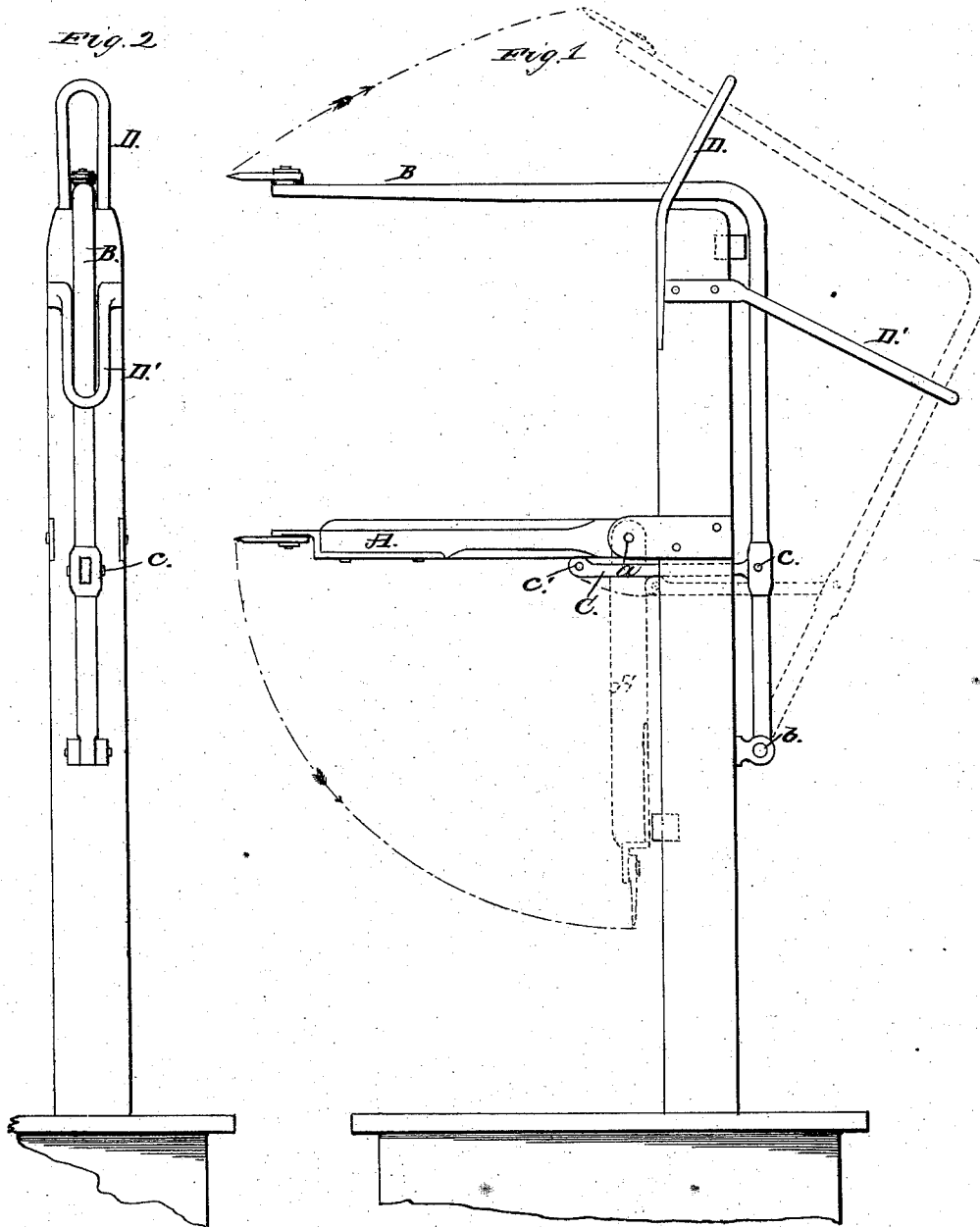

Witnesses:  
S. S. Bloom  
John Ward

Inventor:  
Herman M. Dick

# UNITED STATES PATENT OFFICE.

HERMAN M. DICK, OF SHELBY, OHIO.

## IMPROVEMENT IN MAIL-BAG CATCHES.

Specification forming part of Letters Patent No. **164,677**, dated June 22, 1875; application filed July 7, 1874.

*To all whom it may concern:*

Be it known that I, HERMAN M. DICK, of Shelby, county of Richland, State of Ohio, have invented certain new and useful Improvements in Mail-Bag Dischargers; and declare the following to be such a full, clear, and exact description thereof as will enable others skilled in the art to which my invention relates to make and use it, reference being had to the accompanying drawings, which form a part of this specification.

My invention has for its object such a mechanism that when the mail-bag shall have been discharged the arms or supports by which it was held will instantly drop back, so as to be out of the way, and not liable to injure persons in the cars or in the baggage-car.

In the drawings, Figure 1 is a side view of the improved mail-bag discharger. Fig. 2 is a rear view of same, showing my improvements.

A is the lower arm or support, hinged at *a*, so as to drop down against the post. B is the upper arm or support, hinged at *b*. It is in the form of an elbow. C is a toggle-arm, connected to the elbow or upper arm at *c*, and to the lower arm A at *c'*. D D' are guides, which act at the same time as stops.

The operation of the device is very simple, and is as follows: When the upper arm B is brought into its position to hold the mail-bag it will, in coming forward to position, carry forward at the same time the toggle-arm C. This will lift up the lower arm A. In this po-

sition it will remain until the mail-bag is caught by the receiver upon the train. As soon as the weight of the mail-bag is removed from the upper arm B, the weight of the lower arm A will cause it to drop, and it will carry with it the toggle-arm C, which, in turn, by pressing against the upper arm B, will cause it to drop back in the guides until it is finally stopped, at which time the lower arm A will lie flat down against the post.

It will thus be seen that the instant the mail-bag is removed the arms A and B are thrown back, so as to be out of the way, and they are no longer liable to injure persons upon the car.

I prefer to place pieces of rubber in the localities shown in the drawings, whereby cushions are formed; but, instead of employing rubber, any other suitable material may be employed, or the cushions may be omitted altogether.

The arms A B may be made of any suitable material; but the lower arm A should be of sufficient weight to throw back the upper arm B through the medium of the toggle-arm C.

What I claim is—

The mail-bag discharger, composed of the hinged arms A B and the toggle-arm C, the whole constructed to operate in the manner substantially as described.

HERMAN M. DICK.

In presence of—

JOHN KAHL,  
HIRAM W. HILDEBRANT.