

T. H. & H. BLAMIRE & H. MARSDEN.
Carding-Machine.

No. 164,796.

Patented June 22, 1875.

FIG 3

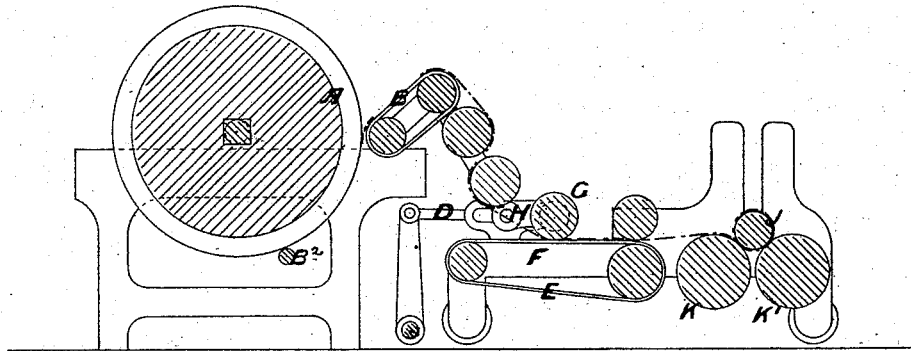

FIG 1

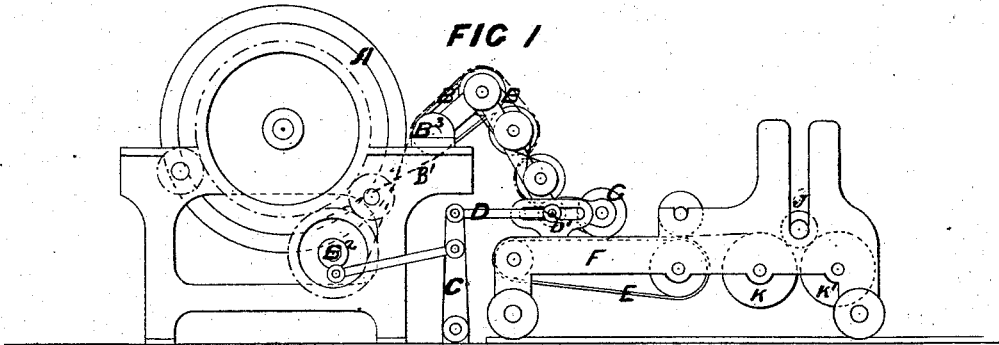
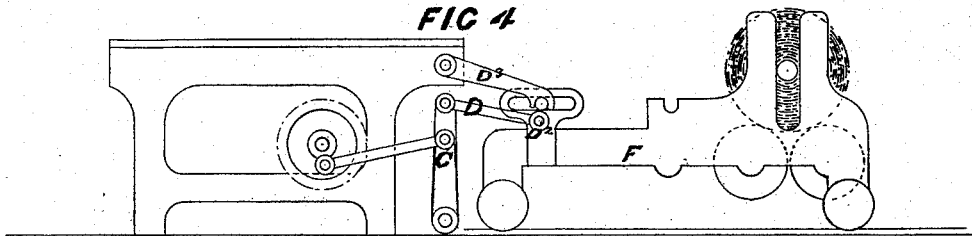

FIG 4



Witnesses

Walter Brailley
Halifax
Worth Law
Bradford

Inventors.

I. Howard Blamires
Henry Blamires
Harry Marsden

T. H. & H. BLAMIREs & H. MARSDEN.
Carding-Machine.

No. 164,796.

Patented June 22, 1875.

FIG 2

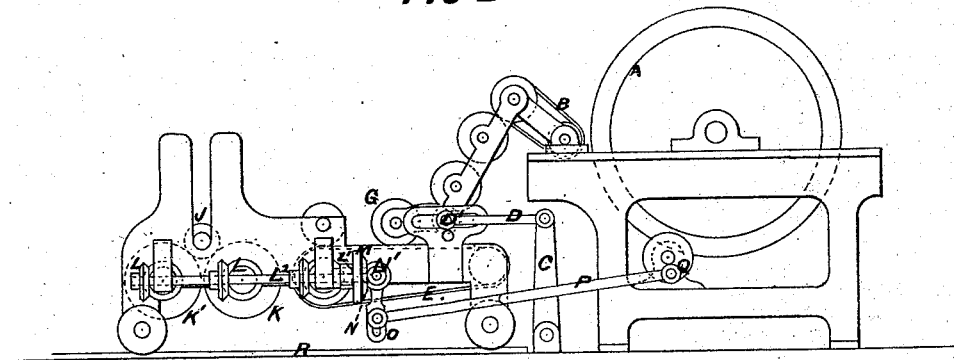
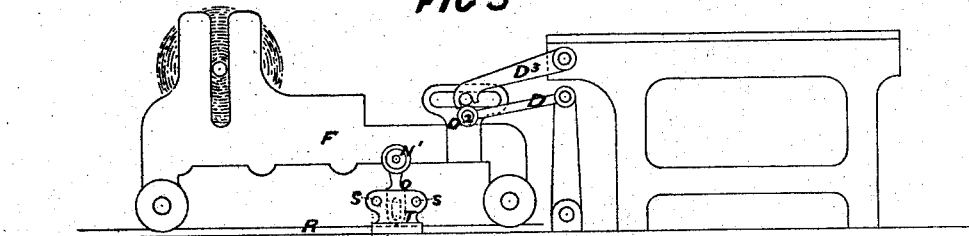

FIG 5



Witnesses,
Walter Brindley
Halifax
Worth Law
Bradford

Inventors,
J. Howard Blamires
Henry Blamires
Harry Marsden

UNITED STATES PATENT OFFICE.

THOMAS HOWARD BLAMIRES, HENRY BLAMIRES, AND HARRY MARSDEN,
OF HUDDERSFIELD, ENGLAND.

IMPROVEMENT IN CARDING-MACHINES.

Specification forming part of Letters Patent No. **164,796**, dated June 22, 1875; application filed
March 16, 1874.

To all whom it may concern:

Be it known that we, THOMAS HOWARD BLAMIRES, HENRY BLAMIRES, and HARRY MARSDEN, of Huddersfield, in the county of York, England, spinners and manufacturers, have invented certain new and useful Improvements in, or applicable to, Carding-Engines; and we do hereby declare that the following is a full, clear, and exact description thereof, that will enable others skilled in the art to which it appertains to make and use the same, reference being had to the accompanying drawings and to the letters of reference marked thereon, which form a part of this specification.

The object of this invention is to take the partially-carded fibrous substance from a scribbler-carder in a direct or longitudinal line as it comes from the doffer of the said scribbler, (instead of taking it at right angles, as at present,) and to wind it in layers or folds upon a roller placed in front of the doffer, thereby to form a lap or roll to be transferred to feed a second carder.

By this means we are enabled to produce a strong and smooth yarn with little twist thereon, and the machine occupies less room than heretofore.

This we effect by employing a creeper to receive the fiber from the scribbler, and deliver it in a folded state to another creeper mounted on a carriage, caused to reciprocate, by the means hereinafter described, under the end of the first creeper, or, instead of the carriage reciprocating the first-named creeper, may be caused to oscillate and deliver the fiber to the second creeper mounted on the carriage, which remains stationary.

In either case a roller is provided, and caused to rotate by the other means hereinafter described, and to wind upon itself the folded film or sheet of the said partially-carded fiber, and thereby to form the lap or roll to be afterward transferred to another or second carder or carding-engine.

Carding-engines with these improvements may also be employed in the manufacture of wadding or felted fabrics.

Figure 1 is a side elevation of the delivery end of a scribbler-carder with our improve-

ments applied thereto. Fig. 2 is an elevation of the opposite side thereof, and Fig. 3 is a cross-section.

A is the doffer-cylinder. B is the creeper, driven by bands from the crank-shaft B², which oscillates or swings on the shaft B³, motion being given to it by means of the crank C and rod D, so that the wool or fiber will be delivered upon the creeper E, which is mounted upon the stationary frame-work F. A pressing-roller, G, is carried in the swing-frame H, hinged to the oscillatory creeper-frame, for pressing the layers of fiber upon the creeper E, which conducts it to the roller J, which, by means of the drums K and K', is caused to rotate and wind the bat or mat of the folded fiber upon itself until sufficiently full, when it is taken away to feed another carder, when one, two, or more of such rolls may be applied together to further equalize the feed.

Intermittent motion is given to the drums K and K' by means of the bevel-wheels L and ratchet-wheel L¹ on the shaft L². The catch for "setting up" the ratchet-wheel is fixed to the plate M, to which is also attached the bevel-wheel N, and they are mounted loosely on the shaft L². The bevel-wheel N gears with another bevel-wheel, N', and they are caused to oscillate or rotate backward and forward by means of the lever O, actuated by the rod P from the crank Q on the shaft B².

Instead of the oscillating creeper, the carriage or frame-work F may reciprocate upon the rails R, (see Figs. 4 and 5,) motion being given to it by means of the crank C and rod D.

The roller J is caused to rotate, as before described, only the lever O, instead of being actuated by the rod and crank, is worked by coming in contact with the pins S S on the stand T, whereby the oscillating motion is communicated to the wheels N and N', as in the first instance.

It will be seen on reference to the drawings that by moving the rod D from the pin D¹ in Fig. 1, and transferring it to pin D² in Fig. 4, and at the same time passing the clip or catch D³ over the pin D¹, the machine-creeper B is stationary, and the carriage F will reciprocate, as hereinbefore described.

We claim—

The creeper B, in combination with the crank C, rod D, pressing-roller G, creeper E, roller J, rollers or drums K K', bevel-wheels L N N', ratchet-wheel L¹, shaft L², and lever O, all arranged and constructed to operate substantially as described, and for the purposes set forth.

In testimony that we claim the foregoing we have hereunto set our hands.

T. HOWARD BLAMIRES.
HENRY BLAMIRES.
HARRY MARSDEN.

Witnesses:

WALTER BRIERLEY, *Halifax*,
WORTH LAW, *Bradford*.