

W. L. NEWSHAM.
Valve-Gear.

No. 164,865.

Patented June 22, 1875.

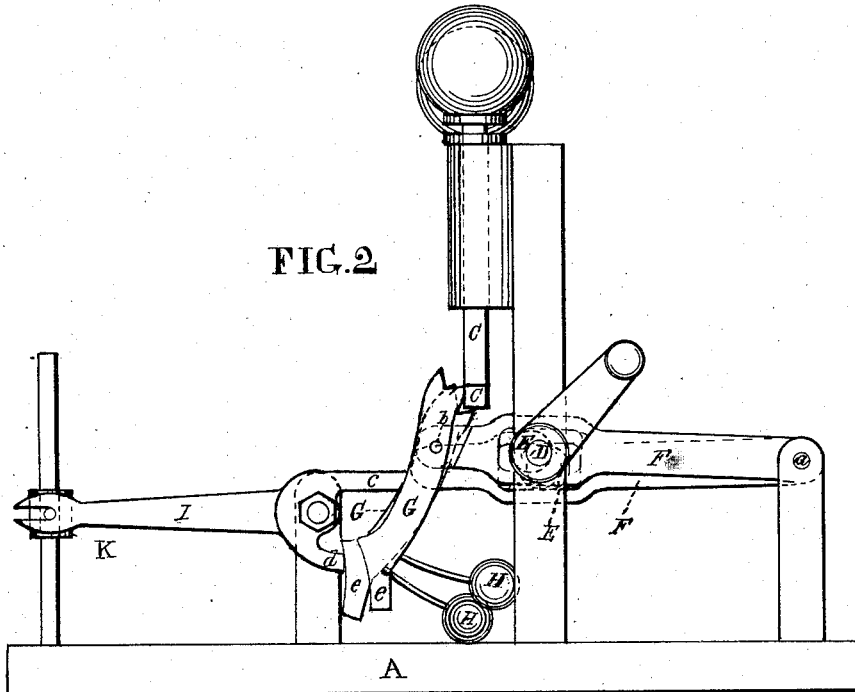
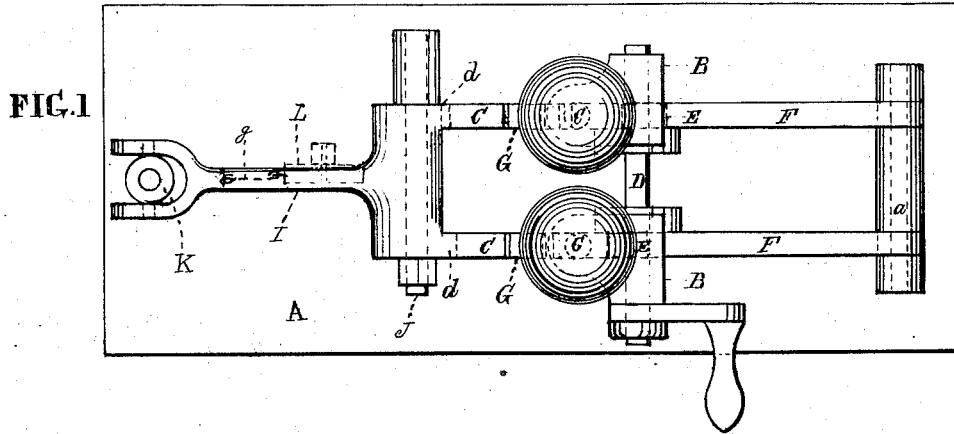

Witnesses
Thomas F. Dewey.
Geo. C. Betzel

Inventor
William L. Newsham
Stephen Ustick, Attorney

UNITED STATES PATENT OFFICE.

WILLIAM L. NEWSHAM, OF PHILADELPHIA, PENNSYLVANIA.

IMPROVEMENT IN VALVE-GEARS.

Specification forming part of Letters Patent No. **164,865**, dated June 22, 1875; application filed May 11, 1875.

To all whom it may concern:

Be it known that I, WILLIAM L. NEWSHAM, of the city and county of Philadelphia, in the State of Pennsylvania, have invented an Automatic Safety-Trip for Corliss Steam-Engines, of which the following is a specification:

The nature of my invention consists in disconnecting the valve-rod lifters from the rods when the governor is disarranged, by the combination of the governor-lever with the lower end of the valve-rod lifters, in such a manner that when the governor-balls drop, carrying the long arms of the lever downward, and consequently the short arms away from the valve-rod lifters, whereby their connection with the rods would be continued, the movement of the above-mentioned connecting device so changes the position of said lifters as to break their connection with the rods as to close the valves. The connection is made with the lower ends of the lifters by means of additional arms of the lever, in combination with extensions of the lower ends of the lifters.

In the accompanying drawings, Figure 1 is a plan view of the governor-lever I and parts in connection, showing my improvement. Fig. 2 is a side elevation of the same.

Like letters of reference in the figures indicate the same parts.

A is a bed-plate, which has uprights B B for the connection of the valve-rods C C and the support of the rock-shaft D, which has bearings therein. The rock-shaft has eccentrics E E for operating the cradles F F, that are hung at one end on the joint-rod *a*, for operating the valve-rods by means of the lifters G G, hung on the front ends of the cradles by means of the joint-pins *b b*. This arrangement for operating the lifters for the movement of the valve-rods is merely for the sake

of illustration. In practice other mechanism is used. H H are counter-weights of the lifters, for bringing them into connection with the lower ends of the valve-rods. I is the governor-lever, hung on the rod J, and connected with the governor-slide K. The lever has arms C C, which operate the lifters. Beneath these arms are arms *d d*, which are brought into contact with the extensions *e e* of the lifters, when the lever I is caused to fall by a derangement of the governor, thereby tilting the lifters, whereby to disconnect their upper ends from the valve-rods, and thus close the valves until the derangement of the governor is corrected. Instead of the combination of the arms *d d* with the extensions *e e* of the lifters, a bell-crank, L, may be connected with the lever I, and the upper ends of the levers by means of wires *g* and *g' g'*, as shown by dotted lines.

The above description applies to an upright engine. A like arrangement would be used for a horizontal engine, the positions of the parts being changed accordingly.

As lifters are made in various forms, corresponding changes will have to be made in the tripping device to suit them.

I claim as my invention—

The combination of the lever I, having arms *e e* and *d d*, with the lifters G G, having extensions *e e*, whereby to trip the lifters, when the lever is caused to drop by a derangement of the governor, and thus to disconnect the lifters from the valve-rods and close the valves, substantially as set forth.

WILLIAM L. NEWSHAM.

Witnesses:

THOMAS J. BEWLEY,
STEPHEN USTICK.