

L. B. WHITE.

Plow.

No. 164,952.

Patented June 29, 1875.

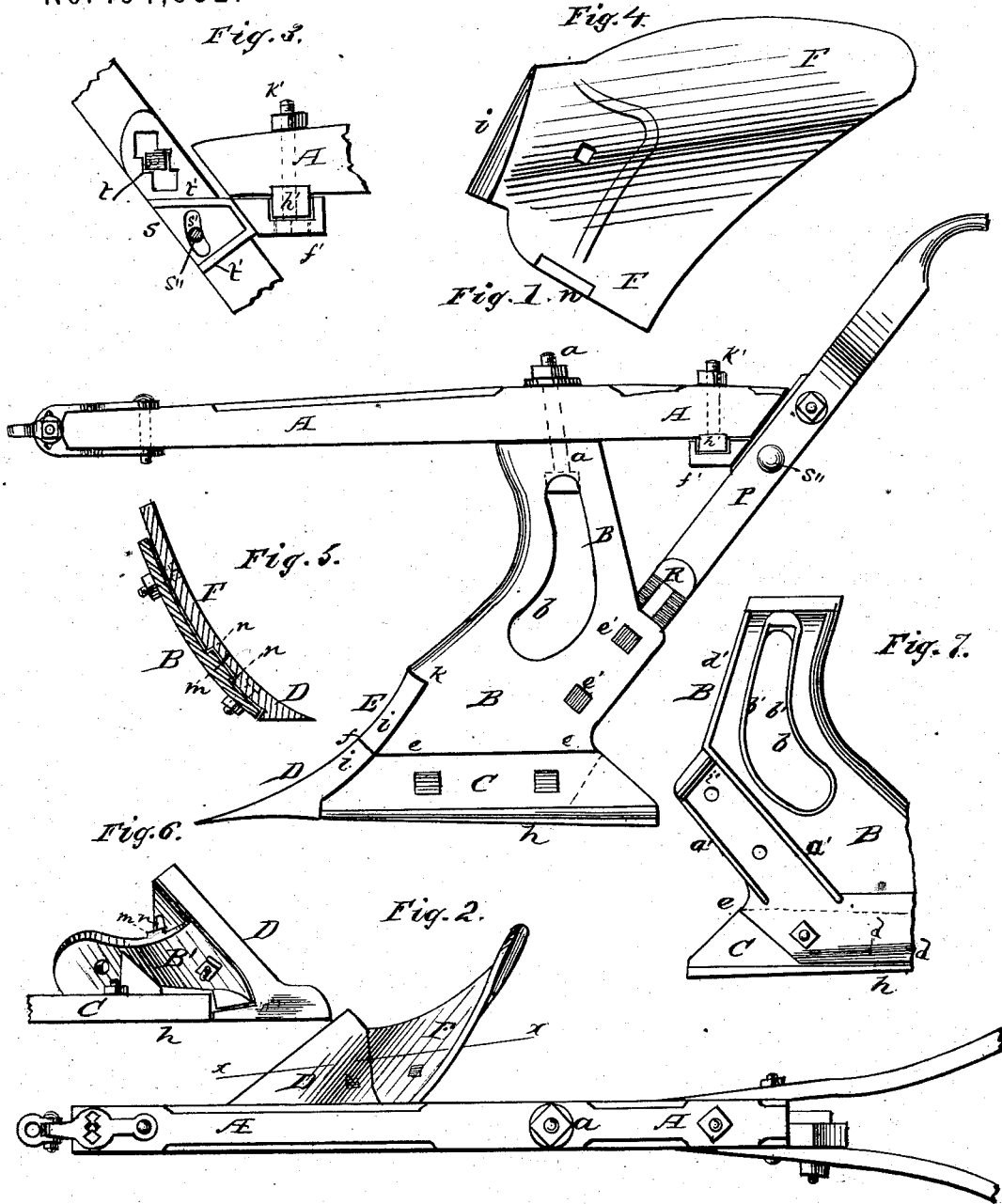

WITNESSES:

P. C. Dieterich
W. C. Scott

INVENTOR:
Lewis B. White

per
C. H. Watson & Co
ATTORNEYS.

UNITED STATES PATENT OFFICE.

LEWIS B. WHITE, OF NORFOLK, VIRGINIA, ASSIGNOR TO HIMSELF AND
S. R. WHITE, OF SAME PLACE.

IMPROVEMENT IN PLOWS.

Specification forming part of Letters Patent No. **164,952**, dated June 29, 1875; application filed
May 8, 1875.

To all whom it may concern:

Be it known that I, LEWIS B. WHITE, of Norfolk, in the county of Norfolk and State of Virginia, have invented certain new and useful Improvements in Plows; and I do hereby declare that the following is a full, clear, and exact description thereof, which will enable others skilled in the art to which it pertains to make and use the same, reference being had to the accompanying drawings, and to the letters of reference marked thereon, which form a part of this specification.

The nature of my invention consists in certain improvements upon the plow for which Letters Patent No. 140,749 were granted to me July 8, 1873, as will be hereinafter more fully set forth.

In the annexed drawing, Figure 1 is a side elevation of my improved plow. Fig. 2 is a plan view of the same. Figs. 3, 4, 5, 6, and 7 are detached views of certain parts thereof.

A represents the plow-beam, to which the frame B is secured by a bolt, *a*, passing up through the top of the frame and through the plow-beam. The opening *b* in the frame is curved forward at its upper end, for the purpose of throwing the bolt *a* farther forward, and thus decrease the leverage from the front end of the beam, and thereby lessen the liability of breaking the bolt. The side of the frame is formed with a horizontal shoulder, *e*, at a suitable height above the lower edge, and along said lower edge is formed an inwardly-projecting inclined and tapering flange, *d*, which is made slightly concave on its under surface. At the point of the frame B is formed a shoulder or abutment, *f*. The inside of the frame B is formed with flanges *b'* around the opening *b*, and also with two parallel flanges, *a'* *a'*, and with a flange, *d'*, as shown in Fig. 7, to obtain the greatest amount of strength. C represents the land-side, which is made pointed at both ends, and provided on each side with a tapering flange, *h*, which commence from opposite ends and gradually run into the body of the land-side, said flanges being convex on their upper surfaces to fit against the concave flange *d* of the frame. When the land-side C is fastened to the frame its upper edge is against and flush with the

shoulder *e*, its point against the abutment *f*, and the flange *h* on its inner side up against the flange *d* of the frame. As the outer side of the land-side becomes too much worn it can be reversed and put back in place, and one end of the flange on the lower part of the land-side is thicker than the other, so that when worn it is reversed. D represents the plow share or point, and E the mold-board. These are both at their inner edges constructed with a flange, *i*, to form a V-shaped groove, which fits over the edge of the frame, and the flange of the mold-board at its upper end interlocking with a shoulder, *k*, on the frame. When the share and mold-board are fastened in place they form one continuous curve from the point to the shoulder *k*, and at this shoulder on the frame is formed, so to say, an elbow, the upper end of the frame forming another curve. On the wing of the frame B is formed a rib, *m*, which comes directly at the junction of the share and mold-board, and fits in recesses *n*, made in their edges for that purpose. This rib acts as a guide in putting on the share and mold-board, and in drilling or reaming the bolt-holes therein. It also acts as a stop for the share and mold-board, so as to relieve the bolts which fasten the same from undue strain, and to prevent the twisting of either share or mold-board. This is of great importance, from the fact that both the share and mold-board are each fastened only by a single bolt.

It will be seen that in operation the flanges *i* of the share and mold-board protect the edge of the frame, and, as they project beyond the edge, they also protect the side of the frame.

P P represent the handles, the lower ends of which are laid between the flanges *a'* *a'* and fastened by bolts *e'* *e'*, the flanges holding the handles firmly in position and relieving the strain on the bolts. Between the frame and the handles is inserted a slotted wedge, R, to pass over the upper bolt, *e'*, and the outer side of this wedge is toothed, as shown in Fig. 1. Between the upper rear ends of the flanges *a'* *a'* is formed an edge, *v*, which engages with the toothed wedge R, to hold the same and prevent its slipping. The object of this wedge is to adjust the handles, as required, more or

less to either side. Between the handles P P, in rear of the beam A, is fastened a slotted and flanged casting, S, formed with a projection, f' , on its front edge. This projection is recessed on its upper side, and provided with an elongated slot. On the under side, at the rear end of the beam A, is a block, h' , let into the beam, which block fits into the recess in the projection f' , said projection resting against the under side of the beam, as shown in Fig. 3. A bolt, k' , is then passed through (from underneath) the slotted projection, block, and beam, and fastened by a nut on top. The rear portion of the casting S forms a flanged extension between the handles, having a slot, s' , in the lower part, to allow the casting to move over the bolt s'' . The upper portion is also slotted and provided with angular openings corresponding in form to the shape of the bolt-head, by which means the casting is adjusted and held in place. The casting is also provided with ribs t' , which holds one of the handles in proper position.

Having thus fully described my invention,

what I claim as new, and desire to secure by Letters Patent, is—

1. The tapering concave flange d , formed on the lower edge of the frame B, in combination with the reversible double-pointed land-side C, provided with tapering flanges h , made thicker on one end than on the other, substantially as and for the purpose specified.

2. The frame B, provided with flanges a' a' and edge v' , in combination with the slotted and corrugated wedge B and handles P, all as and for the purpose herein specified.

3. The casting S, having recessed and slotted projection f' , flanges or ribs t' t' , slot s'' , and slot for bolts t , in combination with handles P, beam A, and block h , all as and for the purpose set forth.

In testimony that I claim the foregoing as my own I affix my signature in presence of two witnesses.

LEWIS B. WHITE.

Witnesses:

C. H. WATSON,

X. C. SCOTT.