

J. DAVENPORT.  
Metal Cap for Posts.

No. 164,979.

Patented June 29, 1875.

*Fig. 1.*

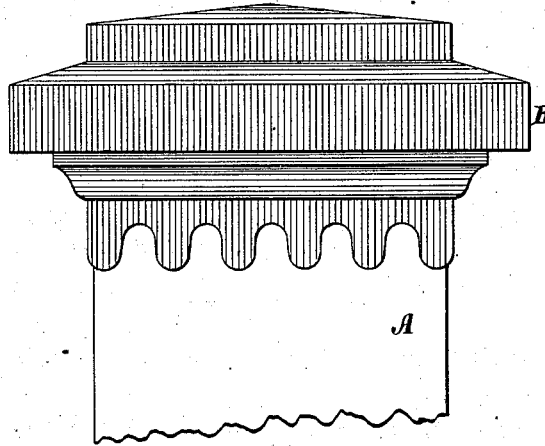

*Fig. 2.*

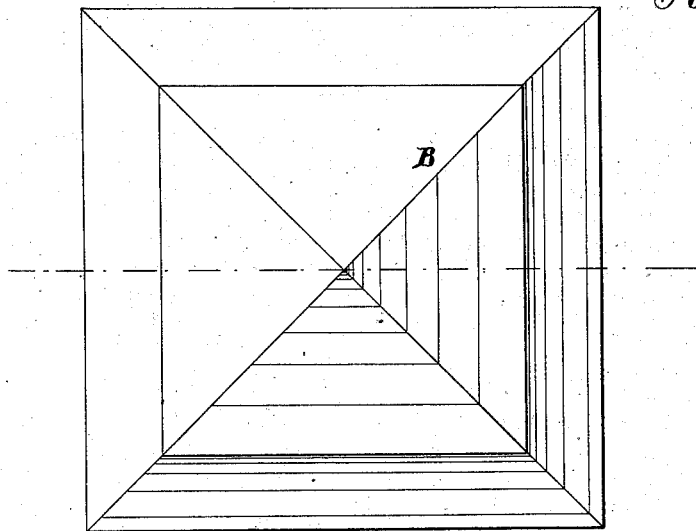

*Fig. 3.*

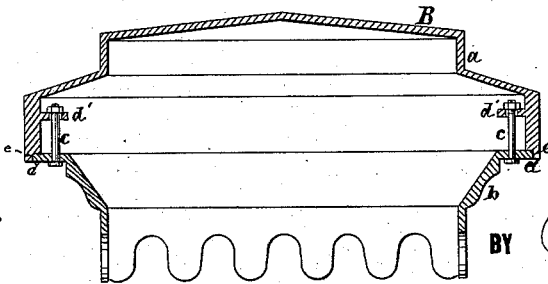

WITNESSES:

*A. B. Terry*

INVENTOR:

*John Davenport*  
BY  
*Munn & Co.*  
ATTORNEYS.

# UNITED STATES PATENT OFFICE.

JOHN DAVENPORT, OF STAMFORD, CONNECTICUT.

## IMPROVEMENT IN METAL CAPS FOR POSTS.

Specification forming part of Letters Patent No. **164,979**, dated June 29, 1875; application filed April 17, 1875.

*To all whom it may concern:*

Be it known that I, JOHN DAVENPORT, of Stamford, in the county of Fairfield and State of Connecticut, have invented a new and Improved Gate or Fence Post, of which the following is a specification:

The invention will first be described in connection with drawing, and then pointed out in the claim.

Figure 1 is a side elevation of the metal cap and a portion of the wood part of a gate or fence post, of my improvement. Fig. 2 is a top view; and Fig. 3 is a sectional elevation of the cap, taken on the line *xx* of Fig. 2.

Similar letters of reference indicate corresponding parts.

A is the wood portion of the post, and B the metal cap, the latter being made in two

parts, *a b*, and secured by bolts C, the bolts being inserted from the under side of the flange *d*, forming the cornice, and the nut being confined by the lug *d'*, cast on the inner wall of the part *a*. The upper part overlaps the lower part at the joint *e*, so as to effectually prevent the rain from getting inside.

Having thus described my invention, I claim as new and desire to secure by Letters Patent—

The metallic post-cap B, made in two parts, *a b*, jointed at *e*, and provided with fastening-bolts C, passing through flange *d* and lugs *d'* as and for the purpose described.

JOHN DAVENPORT.

Witnesses:

JAMES T. GRAHAM,

T. B. MOSHER.