

G. E. TOWER. Valve for Steam-Engines.

No. 165,187.

Patented July 6, 1875.

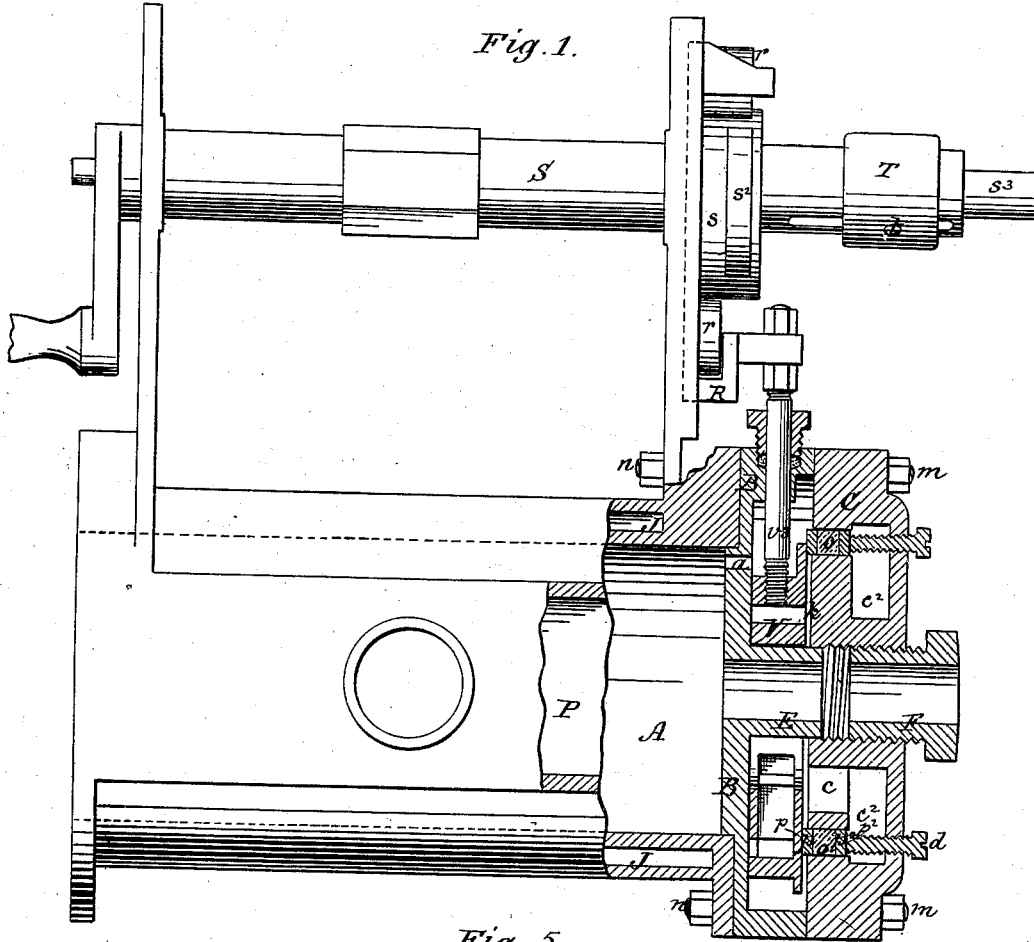
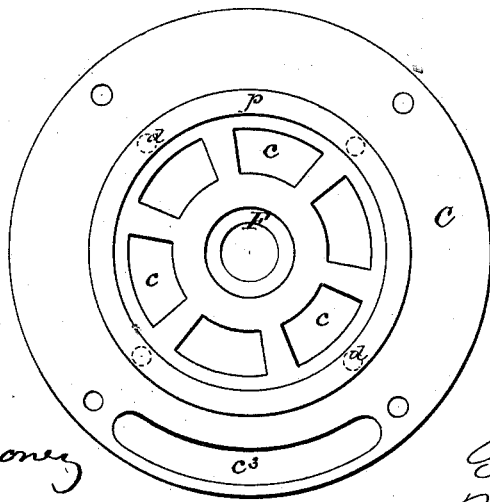

Fig. 1.

Fig. 5.



Witnesses.
E. M. D. Guinness
J. H. Kern

Inventor.
George E. Tower
 By *D. P. Voorhies*
 Atty.

G. E. TOWER.
Valve for Steam-Engines.

No. 165,187.

Patented July 6, 1875.

Fig. 2.

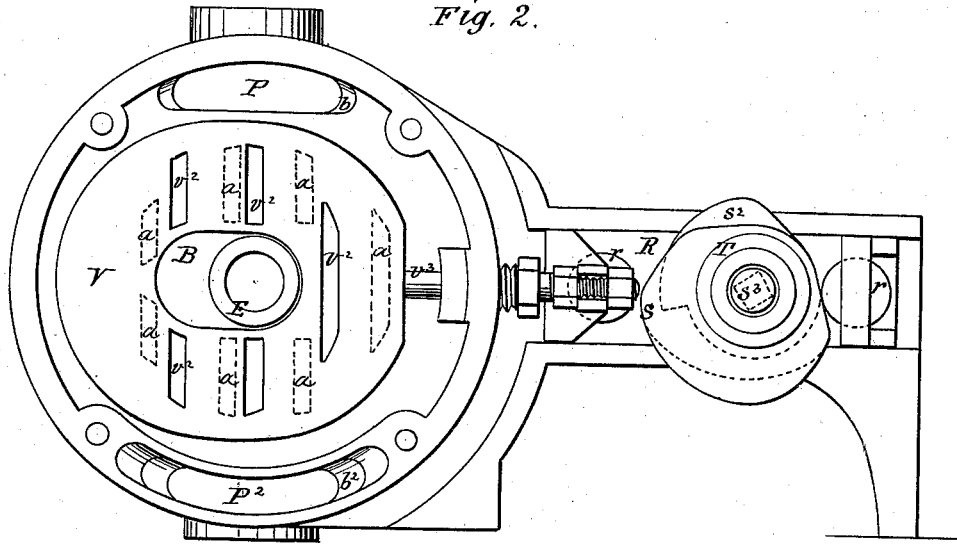

Fig. 3.

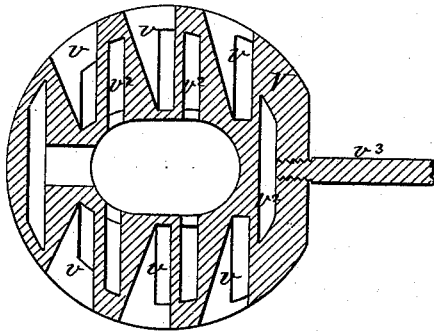
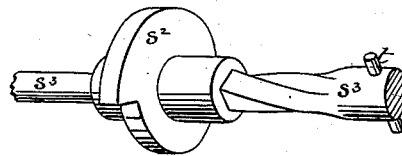

Fig. 4.



Witnesses
 E. Mrs. Quinonez
 J. N. Fear

Inventor.
 George E. Tower
 By R. A. Voorhes
 Atty.

UNITED STATES PATENT OFFICE.

GEORGE E. TOWER, OF ANNAPOLIS, MARYLAND, ASSIGNOR OF ONE-EIGHTH HIS RIGHT TO ROBERT W. BELL, OF SCHODACK LANDING, NEW YORK.

IMPROVEMENT IN VALVES FOR STEAM-ENGINES.

Specification forming part of Letters Patent No. **165,187**, dated July 6, 1875; application filed November 20, 1874.

To all whom it may concern:

Be it known that I, GEORGE E. TOWER, of the city of Annapolis, in the county of Anne Arundel and State of Maryland, have invented certain Improvements in Steam and other Engines, of which the following is a specification:

This invention relates more particularly to the construction of the cylinder-heads, steam-chests, and valves; and its object is to admit of the entrance and exit of the steam directly through the cylinder-heads by means of valves operated therein, instead of through passages in the side or body of the cylinder, as is ordinarily the case, by which means, as herein-after particularly described, there is a saving of steam by the total, or almost total, exclusion of the ordinary loss by "clearance" in the passages leading to the cylinder. By means also of this construction, the entering steam impinges upon the whole surface of the piston in lines parallel to the direction of its stroke through ports in the cylinder-heads, and is controlled and cut off by the main valves of the engine at any desired part of the stroke of the piston, from one-sixteenth to seven-eighths from its commencement, either automatically and variably by the action of a governor, or at a set point, without changing the lead of the valves, without interfering with the exit of the exhaust steam, and without altering the width of opening of any of the ports.

The construction of the various parts of this invention can now be understood by reference to the accompanying drawings forming part of this specification, in which—

Figure 1 is a plan of the cylinder with its valve and valve-gear for one end, partly in section, in a horizontal median line. Fig. 4 is an end view of the cylinder and valve-gear with the steam-chest cover removed, showing the back of the valve.

The other figures are views of the several parts in detail, as hereinafter fully described.

Similar letters indicate the same parts in each figure.

A is the cylinder, surrounded by a steam-jacket, J, and having steam and exhaust side pipes P P² cast on its sides.

By connecting the steam and exhaust pipes with these side pipes, which communicate with the steam-chests, as seen in the drawing, the cylinder-heads and steam-chest covers can be removed without breaking the respective connections of the cylinder with the boiler and condenser.

B is the cylinder-head, which also serves as a steam-chest. *a* are its ports, for the admission and exit of the steam to and from one end of the cylinder; and *b b*² are, respectively, steam and exhaust passages, forming connections with the steam and exhaust side pipes P P². V is the main and only valve for one end of the cylinder, for the admission to, cutting off from, and exit of the steam therefrom. *v* are its steam-ports, distributed around its periphery, passing inward either radially or in lines parallel to its ends, and opening through its face to its seat in the cylinder-head. *v*² are its exhaust-ports, passing axially through it from back to face, and open to its seat. C is the steam-chest cover, forming with the cylinder-head B a closed chest for the valve V. *c* are its exhaust-ports open on one side to the exhaust-ports *v*² of the valve V, and on the other side communicating with the annular exhaust-chamber and packing-space *c*² and exhaust-passage *c*³. The latter passage connects directly with exhaust-passage *b*² in cylinder-head B.

The exhaust-ports *c* in the steam-chest cover and the exhaust-ports *v*² of the valve V are always open to each other within the packing-ring *p*, and hence are always open to the condenser or to the atmosphere through the exhaust-pipe. The valve is thus balanced by the use of this packing-ring, backed by its follower *p*² and interposed rubber gasket *o*, as the back of the valve is thus kept always exposed to only either condenser or atmospheric pressure. This steam-chest and valve are thus adapted to use this simple, efficient, and well-known means of taking the excess of steam-pressure from the back of the valve. This packing is adjusted by means of set-bolts *d*.

E is a sleeve in the cylinder-head, through which the piston-rod passes. This sleeve passes through the center of the valve V, and

fits into a corresponding sleeve or stuffing-box, F, in the steam-chest cover, thus forming when the chest closed the bottom of the stuffing-box.

This stuffing-box need of course be placed but upon one end of the cylinder. In such case the valve V would have no slot through its center, as is seen in the drawing, in order to allow of its movements.

The valve V, instead of being slotted, may be mounted upon the sleeve E, and instead of sliding it may be made to oscillate or partially rotate upon the sleeve E as an axis, or upon an axis on the cylinder-head B, other than a sleeve, if no piston-rod passes through its end of the cylinder. It will be observed that by removing the nuts *n* from their bolts the cylinder-head and steam-chest cover can both be removed together without disturbing the valve V in any way. The head may also be left on and the steam-chest cover alone removed by removing the nuts *m* from their bolts. The valve V is connected by the valve-stem *v*³ to the carriage R, which is provided with differential rollers *r*. The longer one of these rollers receives the motion and wear of both of the rollers *s* *s*², and the shorter one that of the cam *s* only. These cams may be made, if desired, of equal lengths, but such a construction is not thought to be so good. There would likely be more wear, and they would also necessarily be placed out of line with each other in a direction at right angles to their axes. These rollers transmit the action of the cams to the carriage R, which, traversing in its guides, effects the proper movements of the valve V. The valve and its gear for but one end of the cylinder are shown in the drawing, but it is understood, of course, that the other valve is a duplicate, save that the provision made for a piston-rod stuffing-box, shown in the drawing, may be dispensed with, as above mentioned.

The operation of this valve-gear is as follows: S is a revolving shaft, taking its motion from the main shaft of the engine. It is supposed to revolve with its axis at right angles to the main shaft and in the same horizontal plane. It may, however, be mounted with its axis in any desirable plane to actuate the valves of the engine. It is actuated by miter gearing, or by any other suitable means, for transmitting motion from the main shaft. The cam S is an ordinary full-stroke cam, and by its revolution causes the steam to follow full stroke. The cam *s*² is a cut-off cam, partially contained within the cam S. It is partially rotated by the spiral rod *s*³, working through its center, which, protruding it beyond the face of cam S, causes it to close the main valve V at any point after the commencement of its stroke, from one-sixteenth to seven-eighths of the stroke of the piston. This spiral rod *s*³ is inserted with the shaft S, which is bored out to receive it, and it extends through the shaft sufficiently far to operate

the cams at both ends of the cylinder. It is directly actuated by means of the sliding collar T, which, sliding on shaft S, is connected to rod *s*³ by a key traversing in a slot in shaft S, as is clearly shown in the drawing. The revolution of shaft S, therefore, causes cam *s*² to revolve, through the intervention of the key *t* in the sliding collar T, and this collar may either be moved by hand horizontally on the shaft S, and thus set cam *s*² to cut off at any desired point, or it may be connected by any suitable device to a governor, and thus, by the action of the governor, be caused to traverse on the shaft S, and momentarily, if necessary, change the point of cutting off by cam *s*².

The following is the course of the steam in its entrance to and exit from the cylinder: Passing in through side pipe P, it enters the passage *b* in the cylinder-head; thence to the space surrounding valve V; thence through the latter's peripheral ports *v*, and the ports *a* in its seat, to the cylinder. In this position of the valve its exhaust-ports *v*² are lapped by its seat. When these are opened by the motion of the valve, the exhaust steam passes out through ports *a* in the cylinder-head, through the whole thickness of valve V, by ports *v*² and into packed space *k*, thence through inner exhaust-ports *c*, exhaust-chamber *c*², and outer exhaust-passage *c*³ of steam-chest cover C, into exhaust-passage *b*² of cylinder-head B, and thence into exhaust side pipe P², to either the condenser or atmosphere.

In order, as much as possible to diminish loss from clearance, projecting pieces may be formed on the piston to fit into the ports *a* of the cylinder-head, leaving only sufficient clearance between such projections and the face of the valve V.

I do not confine myself to the precise arrangement of the ports in the valve V, herein described, as other arrangements of ports may be made without departing from the principle of my invention of combining a sliding or oscillating disk-valve or plate-valve with the cylinder-head. I do not confine myself to actuating the valves solely by cams, as herein described, as they may be actuated by eccentrics or in any other known manner.

I do not claim the valve-gear herein described, reserving that for the subject of an application for other Letters Patent; but

Having thus fully described my invention, I claim—

1. Plate or disk valves, having a rectilinear reciprocating motion, in combination with the two cylinder-heads of a steam-engine, whereby the steam is suitably controlled in its entrance to and exit from the cylinder in actuating the piston thereof.

2. A box-valve V, provided with peripheral steam-ports *v*, and axial exhaust-ports *v*², whereby the valve is rendered capable of re-

ceiving either rectilinear or angular motion, in the manner substantially as described, for the purposes set forth.

3. The combination, with the cylinder-head of a steam-engine, of a box-valve, V, centrally slotted for the passage through it of the piston-rod and the allowance of its own rectilinear motion, in the manner substantially as described, for the purposes set forth.

4. A combined cylinder-head and steam-chest, B, provided with respective steam and exhaust passages b b^2 and ports a , in the manner substantially as described, for the purposes set forth.

5. A steam-chest cover, C, provided with

inner exhaust-ports c , annular exhaust-chamber and packing-space c^2 , and outer exhaust-passage c^3 , in the manner substantially as described, for the purposes set forth.

6. The combination of the cylinder-head B and steam-chest cover C, each constructed substantially as described, whereby a suitable valve-chamber is provided for the valve V, and a stuffing-box provided for the piston-rod, all in the manner substantially as described, for the purposes set forth.

GEO. E. TOWER.

Witnesses:

E. MCB. TIMONEY,

J. H. GEAR.