

L. J. MARCY.
Magic Lantern.

No. 165,242.

Patented July 6, 1875.

Fig: 1

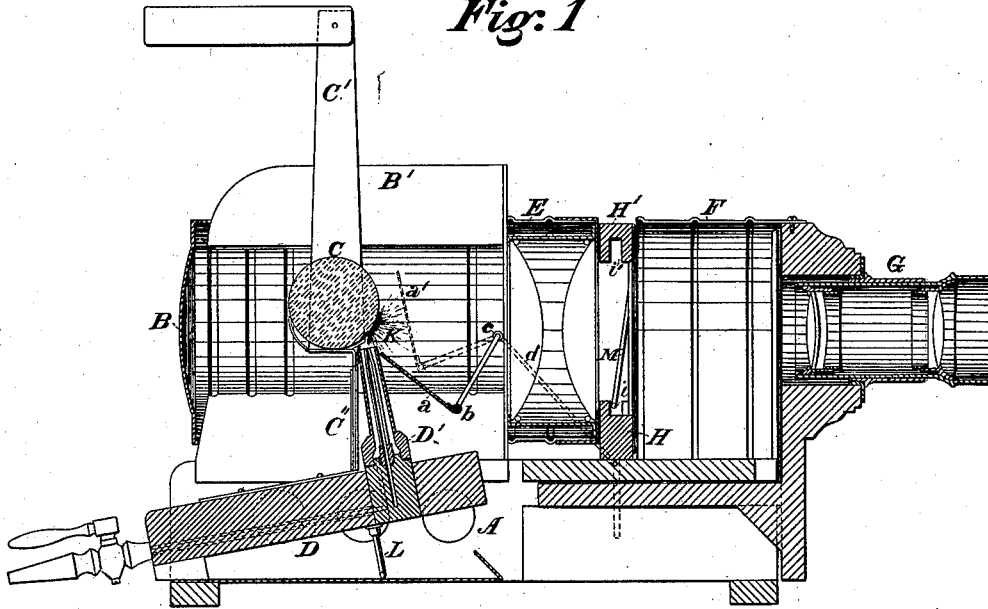
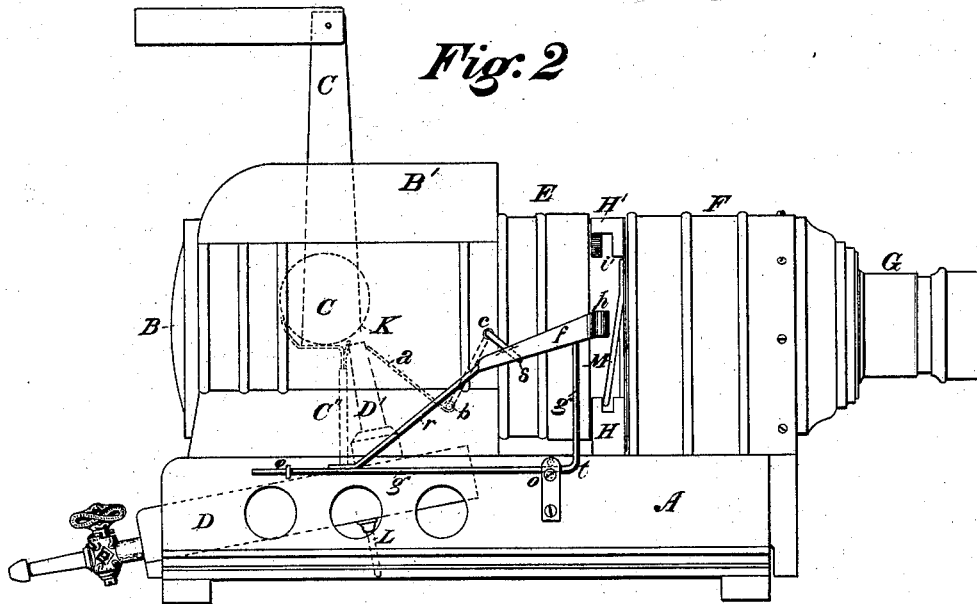

Fig: 2



Witnesses:

John C. Ewing
John McConaghy

Inventor:

Louisa J. Marcy
by his attorney
Jos. C. Fraley

L. J. MARCY.
Magic Lantern.

No. 165,242.

Patented July 6, 1875.

Fig. 3

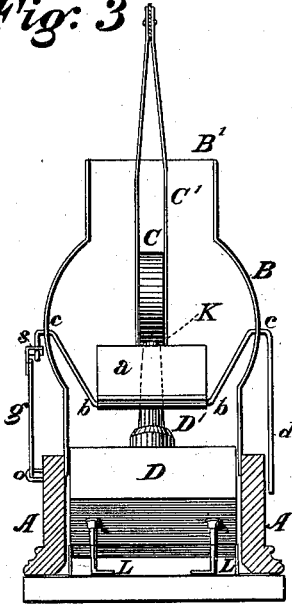
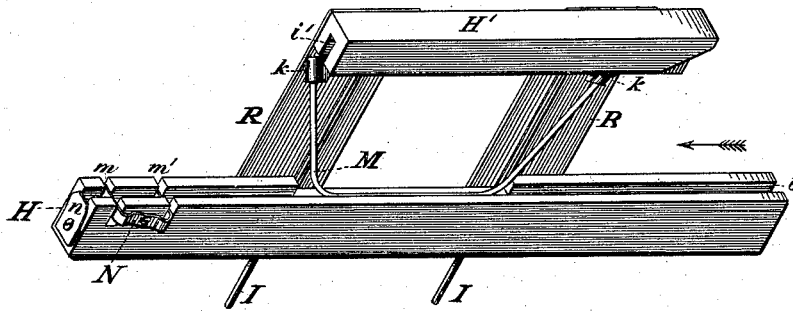

Fig. 4



Witnesses:

John H. Conway
John H. Conway

Inventor:

Lorenzo J. Marcy
by his attorney
Geo. C. Friley

UNITED STATES PATENT OFFICE.

LORENZO J. MARCY, OF PHILADELPHIA, PENNSYLVANIA.

IMPROVEMENT IN MAGIC LANTERNS.

Specification forming part of Letters Patent No. **165,242**, dated July 6, 1875; application filed June 16, 1875.

To all whom it may concern:

Be it known that I, LORENZO J. MARCY, of Philadelphia, Pennsylvania, have invented certain new and useful Improvements in Stops for Magic Lanterns, of which the following is a correct specification:

Previous to the invention of my improved stop, which, from the peculiar effect produced by it, I denominate a "winker-stop," it has been the practice to place stops or flaps in front of the lenses of the lantern, on the side farthest from the light. These stops or flaps consist, essentially, of plates of opaque material, so arranged that they can be drawn or turned entirely across the tube which contains the lenses, thus cutting off the light, and producing the effect of a dark curtain, with a clearly-defined edge, falling upon the screen, as is described in Letters Patent granted to me May 4, 1875.

My present improvements consist, first, in placing the stop in close proximity to the source of illumination, where its size may be much reduced without impairing its efficiency, and its advantages lie in the rapidity and ease of manipulation which result from its small size and position, whereby I obtain entirely new effects, and am enabled to accomplish with a single lantern what formerly required the use of two; and, second, in an apparatus by which flaps or stops can be operated automatically by the movement of the picture or slide.

The accompanying drawings represent my improvements as applied to the cylindrical lantern patented to me July 6, 1869, and with the lime-light also patented to me May 11, 1875, Figure 1 showing a vertical longitudinal section of such a lantern and light with my improvement; Fig. 2, an elevation, and Fig. 3 a vertical transverse section, thereof. Fig. 4 shows the slide-frame detached from the lantern.

It is apparent, however, that my improvements are equally well adapted to any of the usual forms of lanterns and illuminating apparatus, and their use is not to be considered as limited to the arrangement which is here shown for convenience merely.

The lantern-body B B' rests upon a wooden base, A A, which also serves to support the

lens-tubes E and G, the hood F, and the slide-frame H H'. Within the body of the lantern is the illuminating apparatus, consisting, in this instance, of a base-plate, D, supported upon legs L L, a jet or burner, D', and lime-disk C, held in the lime-rest C' C'', the source of illumination being at K. Immediately in front of the burner is placed the stop *a*, consisting of a small opaque plate, preferably of thin metal, held by arms *b b*, which at *c c* are bent so as to pass out through holes in the lantern-body, and are prolonged downward, on one side forming a long lever, *d*, on the other the short one *s*. The holes at *c c* are large enough to permit the free revolution of the arms, and, by depressing the end of the lever *d*, the stop will be raised from its normal position to that indicated by the dotted lines at *a'* in Fig. 1.

It will be seen that the small flap *a*, being, when raised, close to the light K, will cut off all the rays from the lenses and darken the screen as completely as a large flap in any other position, and that its small size and position enable it to be operated by a very slight movement. If this movement is quickly made, by raising and lowering the stop with a tap of the finger upon the lever *d*, the instantaneous darkening and reillumination of the screen produce an effect similar to winking; and, though the interval of darkness is scarcely appreciable to a spectator, the picture can easily be changed during its continuance. By so doing the views can be "dissolved" without the use of the cumbrous double lantern hitherto employed for that purpose.

To insure still greater facility of manipulation I provide a device by which the stop is automatically worked by the movement of the slides themselves as they are changed. The apparatus is shown in Figs. 2, 3, and 4.

The short lever-arm *s* of the stop *a* is freely attached to a light frame-work, consisting, preferably, of a thin strip of brass, *f*, fastened to wires *r* and *g g'*, the latter bent at *t* into a right angle. The frame-work is held at *o o* by rests, in which it can slide horizontally in a direction parallel to the axis of the lantern-body. The strip of brass *f* is bent at its free end into a V-shaped latch, *p*, the point of which is outward, and which extends in breadth al-

most across the opening for the insertion of slides into the slide-frame. The slide-frame consists of two parallel strips, $H H'$, connected together by uprights $R R$, and having longitudinal grooves $i i'$, in which the slides will fit. A holding-spring, M , fastened at $K K$, serves to press the slides firmly against the side of the grooves nearest to the lantern-body, and the whole structure is held upright by pins $I I$ inserted in the base A . When the slide-frame is in position, as shown in Figs. 1 and 2, the glass slide is slipped along the grooves $i i'$ (from the side represented in Figs. 1 and 2 as nearest the spectator, and in the direction of the arrow in Fig. 4) until it occupies the field of the lenses. If it is now desired to change the picture, a second slide is inserted in the grooves, and pushed after the first one. As soon as it reaches the V -shaped latch p , against which it is held by the spring M , it pushes the latch and frame-work $f r g g'$ backward, and thus depresses the lever s . This motion raises the stop a , and cuts off the light until the second slide has pushed away the first and occupied the field. At this moment it releases the latch p , when the stop a falls by its own weight, sliding back the frame-work to its first position, and permitting the light to pass through the picture. These movements can be made instantaneously, and the picture changed during what appears to be a wink of darkness upon the screen.

In order to arrest the second slide when exactly in the field of the lenses I provide, near the end of the strip H toward which the slides move, two slots, through which pass the ends $m m'$ of a turn-buckle, pivoted at N . These slots are of such depth that when the turn-buckle is horizontal the ends $m m'$ are flush with the bottom of the groove i , and when either end is raised the other is below the bottom of the groove. There are three sizes of glass slides in common use, and when the smallest of them are to be exhibited the end m' of the buckle is raised. It obstructs the groove i at such a distance from the field that when one slide is pushed forward by another the first one will be arrested by it, and stop the second just when the latter is in the center of the field. The first slide can then be lifted out, and the operation repeated.

The arms of the turn-buckle are of such a length that when the medium-sized slides are

to be used the end m is raised, and the slide, passing over the end m' , is stopped at m , leaving the slide, which follows in the proper position. When the largest-sized slides are to be used the buckle is turned horizontally, so that the slide passes over both m and m' , and is stopped by the catch n at the end of the groove, with a similar result. The relative distances of m' , m , and n from the center of the field can, of course, be varied to suit any sizes of glass or other slides, and hence I do not so specify them as to confine them to any particular position in the piece H .

By these appliances the apparatus can be worked with ease and perfect precision in the dark, and with a quickness hitherto unattainable.

Having thus described my invention, what I claim as new, and desire to secure by Letters Patent, is—

1. The stop a , or its equivalent, when placed immediately in front of the source of illumination.

2. The combination of the stop a , or its equivalent, in the position specified, with the long lever d , substantially as described.

3. The frame-work $f r g g'$, sliding in rests $o o$, and having the V -shaped latch p , or its equivalent, substantially as described.

4. The combination, substantially as described, of the frame-work $f r g g'$, latch p , or its equivalent, and the slide-holder $H H'$.

5. The combination, substantially as described, of the frame-work $f r g g'$, the latch p , or its equivalent, the slide-holder $H H'$, and the holding-spring M .

6. The combination of a slide-holder and a latch, p , or its equivalent, connected with a stop, whereby the movement of the slide is made to operate a stop for shutting off the light.

7. The turn-buckle $m m'$ and catch n , substantially as described, and for the purposes specified.

8. The combination, substantially as described, of the slide-holder, the turn-buckle $m m'$ and catch n , the holding-spring M , and the automatic stop-closing apparatus.

LORENZO J. MARCY.

Witnesses:

JOS. C. FRALEY,

JOHN M. CONAGHY.