

P. MIHAN.  
Ventilator.

No. 165,245.

Patented July 6, 1875.

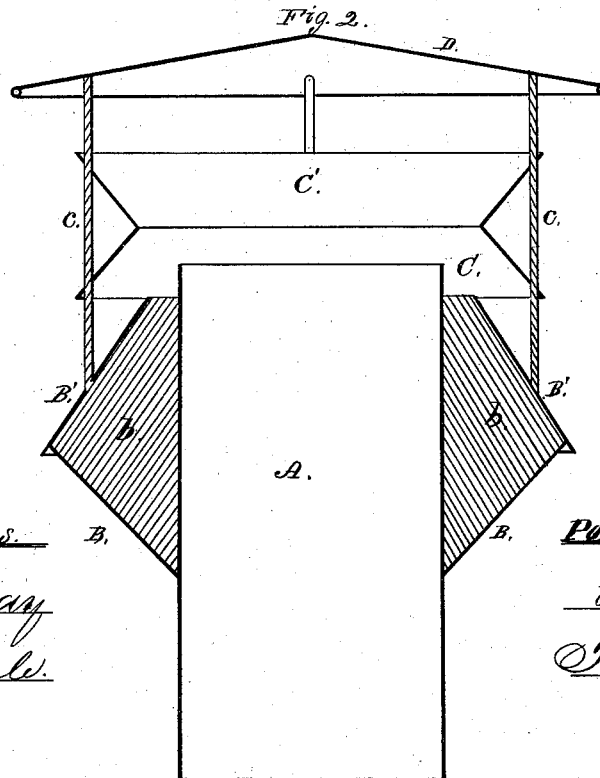
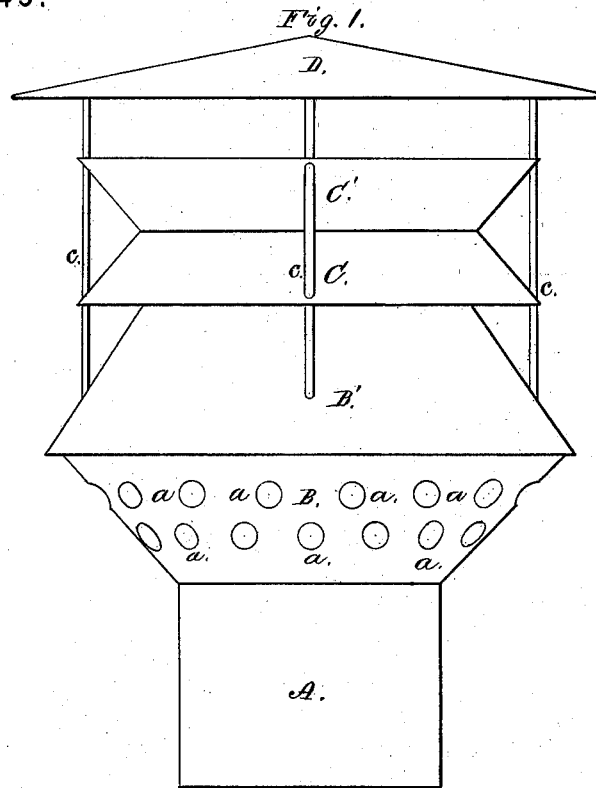

Witnesses. B.

*Geo Gray*  
*E. W. Hale.*

Patrick Mihan

*by his attorney*  
*J. P. Hale*

# UNITED STATES PATENT OFFICE.

PATRICK MIHAN, OF CAMBRIDGEPORT, MASSACHUSETTS.

## IMPROVEMENT IN VENTILATORS.

Specification forming part of Letters Patent No. **165,245**, dated July 6, 1875; application filed March 11, 1875.

*To all whom it may concern:*

Be it known that I, PATRICK MIHAN, of Cambridgeport, in the county of Middlesex and State of Massachusetts, have invented certain new and useful Improvements in Draft-Accelerators or Ventilators; and I do hereby declare that the following is a full, clear, and exact description thereof, which will enable others skilled in the art to which it pertains to make and use the same, reference being had to the accompanying drawing and to the letters of reference marked thereon, which form a part of this specification.

In the said drawing, Figure 1 denotes a side elevation, and Fig. 2 a central and vertical section, of a ventilator constructed in accordance with my invention.

The object of my invention is to produce a more effective device for ventilating buildings, &c., than devices of this character as heretofore employed; and my invention consists in the peculiar construction and arrangement of the several parts, as hereinafter described and claimed.

In the said drawing, A denotes the main ventilating-pipe, which may be of a cylindrical or other desirable shape, the same to be affixed to the top of the building or structure to be ventilated. B B' are two hollow truncated cones or conic frustums, which are disposed around the pipe, such frustums being united at their larger bases. The lower frustum or part B is formed with one or more series, *a*, of openings or air-inducts, extending transversely around the same, such part, at its lower end, being closed, and soldered or otherwise firmly affixed to the pipe A, and thereby affording a secure support on which to sustain the superior parts of the ventilator. The part B' is open at top, and terminates at a short distance below the upper or eduction end of the pipe A. Disposed within the chamber formed by the parts B B', and at equal distances apart, are four or any other desirable number of vertical partitions, *b*, two of such being shown in Fig. 2. Such partitions divide the said chamber into separate air flues or passages, the same serving to prevent that horizontal or lateral deflection of the currents which would result were no partitions employed. Disposed above the frustums B B' is what I term a "storm-

guard," the same consisting of two short truncated cones or conic frustums, C C', which are united at their lesser bases, their plane of junction being at a distance above the upper end of the pipe A equal to that of the frustum B' below the same. By thus uniting the parts C C' at their lesser bases, a chamber is formed horizontally around the outer surface of the guard or frustums C C', which serves to receive and deflect outwardly the snow or rain which may impinge against the guard. Such angular chamber also serves to carry the impinging currents of air horizontally around the guard, and thus by their action to aid in diminishing the outside pressure upon the eduction end of the frustums C' of the guard. The said guard is secured in position by rods *c*, extending up from the frustum B'. D is the dome or deflecting-cap, the same being disposed over the frustum C', and is secured to the tops of the rods *c*, such dome having a diameter somewhat larger than the frustums disposed below it. By this construction the parts below are better protected from the snow or rain or the droppings from the roof of the dome.

Having described the construction of my improved ventilator, its operation is as follows: Currents of air enter the openings in the lower frustum B, and ascend in vertical streams upward around the foul-air pipe A. Before reaching the upper end of the pipe they are re-enforced by the auxiliary ascending currents entering between the frustums B' and C, such frustums being arranged concentrically, and being of such taper that the apex of the frustums, if produced, would terminate at or near the apex of the dome.

By this construction and arrangement the combined pure currents, while having an upward tendency, will be kept from blowing directly across the mouth or eduction end of the foul-air pipe, so as to check the ascent of the impure air issuing from such pipe, as would be the case were the top of the eduction-pipe arranged below the apex or lesser base of the frustum B'.

From the frustum C the combined currents of pure and impure air pass into and through the diverging frustum C', and escape from the opening under the dome.

By this construction of the frustum C' the dome is enabled to be brought down nearer to such frustum, so as to better prevent the entrance of snow or rain into the interior of the ventilator, and at the same time by its increasingly greater area serves to facilitate the discharge of the impure air.

Having described the construction and operation of my invention, what I claim is—

The combination, with the main pipe A, of the conic frustums B, B', the storm-guard or

frustums C, C', and dome D, the whole being constructed and arranged substantially as shown and described.

In testimony that I claim the foregoing as my own invention I affix my signature in presence of two witnesses.

PATRICK MIHAN.

Witnesses:

F. P. HALE,

F. C. HALE.