

J. H. ELWARD.  
Harvester.

No. 165,316.

Patented July 6, 1875.

Fig. 1.

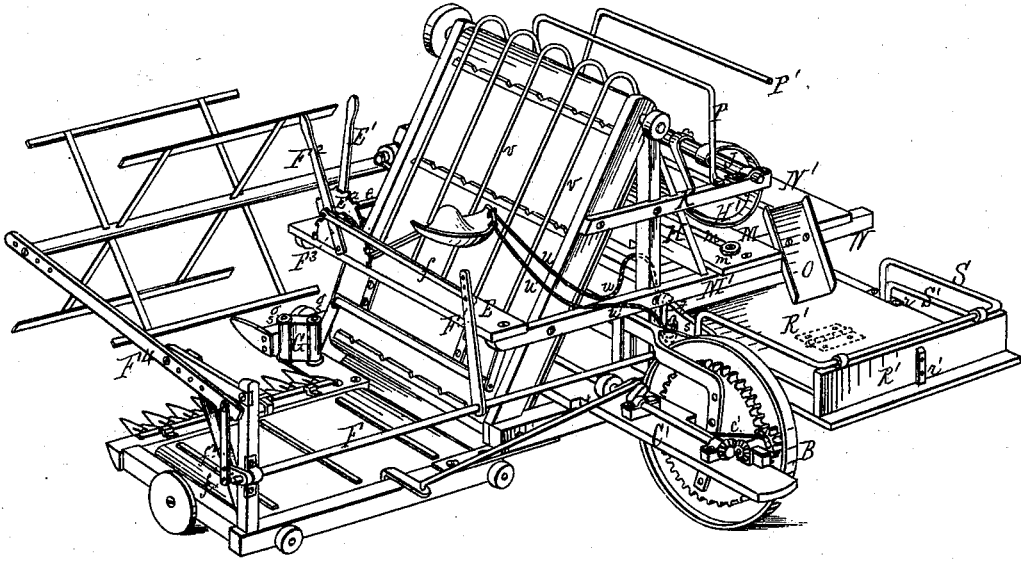
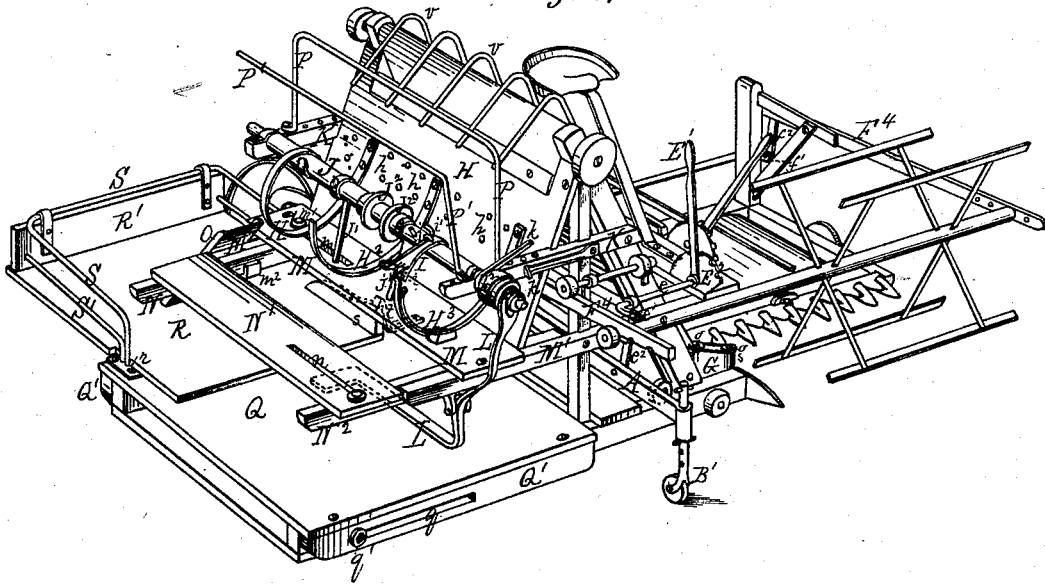

Fig. 2.



Witnesses:  
 Alex Mahon  
 John S. Center.

Inventor:  
 John H. Elward  
 by A. M. Smith  
 Attorney.

J. H. ELWARD.  
Harvester.

No. 165,316.

Patented July 6, 1875.

Fig. 3.

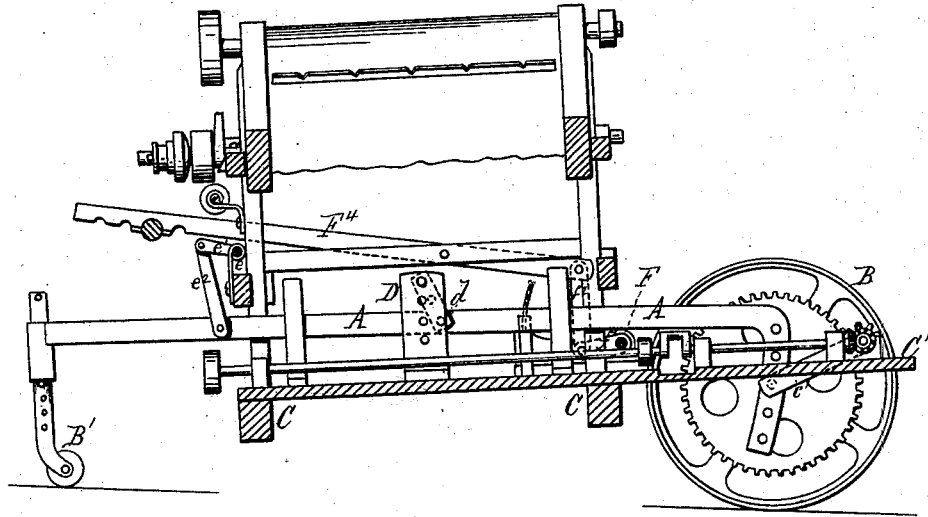

Fig. 4.

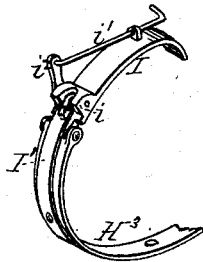

Fig. 5.

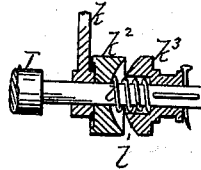
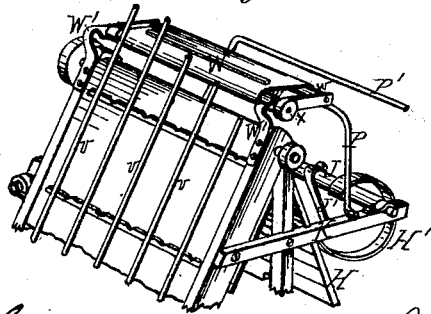

Fig. 6.



Witnesses:  
*Alex Mahon*  
*John G. Center.*

Inventor:  
*John H. Elward*  
 by *A. M. Smith*  
 Attorney

# UNITED STATES PATENT OFFICE.

JOHN H. ELWARD, OF ST. PAUL, MINNESOTA.

## IMPROVEMENT IN HARVESTERS.

Specification forming part of Letters Patent No. 165,316, dated July 6, 1875; application filed March 26, 1875.

*To all whom it may concern:*

Be it known that I, JOHN H. ELWARD, of St. Paul, county of Ramsey, State of Minnesota, have invented a new and useful Improvement in Harvesting-Machines, of which the following is a full, clear, and exact description, reference being had to the accompanying drawing making part of this specification, in which—

Figure 1 is a perspective view of my improved machine, taken from the rear grain-side corner. Fig. 2 is a similar view, taken from the front stubble-side corner. Fig. 3 is a vertical longitudinal section, showing the truck bar or frame and the devices for suspending the harvester-frame therefrom, and Figs. 4, 5, and 6 represent details hereinafter described.

Similar letters of reference, wherever used, represent the same parts.

The invention relates, first, to the manner of suspending the harvester-frame upon the truck bar or frame, and to the devices for effecting the adjustment of the same; second, to the means for effecting the adjustment of the reel; third, to a novel means for moving the grain well back at the heel or delivery end of the platform, prior to its delivery to the elevator; fourth, to the construction and arrangement of the adjustable grain-receiving fingers, and to the bundle compressing and discharging devices, operating in connection therewith; fifth, to the manner of adjusting the binder's platform and seat or band-table; sixth, to the means for controlling the dumping-tray; and, lastly, to certain details of construction and arrangement hereinafter fully set forth.

In the accompanying drawings, A represents a truck bar or frame, which may be of any suitable form and construction, and which passes through the space underneath the elevator ordinarily occupied by the drive-wheel in this class of machines. This bar or frame is supported at one end by the drive-wheel B, and at its opposite end by an adjustable caster-wheel, B', or truck, as preferred, by means of which the height of said end of the bar may be adjusted. The drive-wheel end of this bar or frame is open or forked, (see Fig. 1,) and is provided upon opposite sides of the drive-wheel with grooved or perforated segments, in which the drive-wheel axle is

mounted, and by means of which the height of said end of the bar or frame A may be adjusted as desired. C represents the harvester-frame proper—that is to say, the frame carrying the cutting apparatus, the raking and elevating mechanism, and the binders' grain receptacle, stand, &c., and which may be of any usual or preferred form and construction for that purpose. Upon this frame is a double or an inverted U-shaped standard, D, which strides the bar A, to which the standard is connected by a swinging link or block, *d*, pivoted at one end to the truck bar or frame A, and at the other to the frame C, and serving to suspend the frame C from the truck bar or frame, the location of the standard or point of suspension D being near the center of gravity of the frame C and its attachment, with a slight preponderance in front and at the grain-side for keeping the cutters properly down to their work, while at the same time permitting the ready tilting of said frame for raising or depressing the cutters. The link *d*, provides for a relative longitudinal vibration of the frame A and C, and the standards D and link *d*, are both provided with a series of perforations, adapting them to be adjusted relatively to each other for suspending the frame C at different heights. An extension, C', of the frame C, or of the gear-plank, accommodates the bearings of the pinion or bevel-wheel shaft *c*, and a link, *e*', pivoted at one end on and vibrating around the main drive-wheel axle, and at the other upon the pinion-shaft, serves to hold the drive-wheel and pinions always in proper working relation while permitting the relative longitudinal vibration of the frames A and C referred to.

The seat-plank E, which is located over the elevating mechanism on the usual overhanging transverse bars, has connected with it, within convenient reach of the driver in his seat, a lever, E<sup>1</sup>, attached to one end of a rock-shaft, *e*, mounted in suitable bearings on the elevator-frame, and provided at its opposite end with a crank-arm, *e*<sup>1</sup>, which is connected by a link, *e*<sup>2</sup>, with the truck bar or frame A. By vibrating the lever E<sup>1</sup> backward or forward the frame C may be rocked on its standard D for raising or depressing the cutters, as desired, and a rack, E<sup>2</sup>, serves to hold the lever E<sup>1</sup> at any desired point of adjust-

ment. At the rear of the main and platform frames, in suitable bearings, is mounted a horizontal rock-shaft, F, operated by a vertical arm or lever, F<sup>1</sup>, connected at its upper end by a link, *f*, with a lever, F<sup>2</sup>, pivoted upon the seat-plank within convenient reach of the driver, and held at the desired adjustment by a rack, F<sup>3</sup>. The ends of the shaft F are provided with crank-arms *f*<sup>1</sup>, connected, by links *f*<sup>2</sup>, with the rear ends of the pivoted reel-bearers F<sup>4</sup>, and by the adjustment of these cranks, by means of the lever F<sup>2</sup> through the connecting devices described, the height of the reel can be readily adjusted by the attendant while the machine is in operation for adapting it to the condition of the grain. Upon the inner shoe, which, together with the elevator, is extended some distance in front of the bar to which the cutters are attached, I place two vertical pins or shafts, upon which are placed rollers *g g*, carrying a short endless apron, G, set obliquely to the line of the cut with the rear end or roller nearest the elevator. This apron may be operated either by the friction of the passing butts of the grain, or it may be given a positive movement by gears or belt and pulleys from any convenient driving-shaft, the movement of the apron in either case serving to move backward the butts of the grain projecting over the finger-bar. In some cases a single enlarged roller, rotating backward and inward toward the elevator, will be found to answer the purpose efficiently.

The platform and elevator frames, and the raking and elevating mechanism connected therewith, may be of any usual or preferred constructions.

The inclined delivery-board H, down which the grain slides after it is discharged by the elevator, is provided with several series of perforations at *h*, (or it may be longitudinal slots,) adapting it to have a number of receiving-hooks or curved arms, H<sup>1</sup> H<sup>2</sup> H<sup>3</sup>, attached to it, and to permit their adjustment forward and backward, according to the length of the straw.

Where these arms are designed for receiving the grain only, to be removed by hand, they will all be made in the concave or semi-circular form represented by H<sup>2</sup>; but where it is desired to have the bundle compressed and removed automatically, the rear and front arms will be constructed as follows, namely: the rear arm or hook H<sup>1</sup> has its outer end extended in a curved line, and is carried upward around, and is supported by, the rotating compressor-shaft J, closely clasping, but permitting the rotation of, said shaft. The forward arm H<sup>3</sup> extends to about the same distance as H<sup>2</sup>, and there has a curved extension, I, hinged to it, (see Fig. 4.) the swinging end of said extension reaching upward to, and partially grasping, the shaft J.

The extension I at its hinged end is provided with a forked spur, *i*, and when the arms H<sup>1</sup> H<sup>2</sup> H<sup>3</sup> are receiving the grain a spring, I', fastened to the arm H<sup>3</sup>, drops in behind said spur,

and locks it firmly down on the shaft J, causing it to act as a rigid extension of the arm H<sup>3</sup>; but when the shaft J is rotated for discharging the bundle, a pin or spur, *j*, on said shaft strikes against a hooked end of a slide, *i*<sup>1</sup>, and through a lever-arm, *i*<sup>2</sup>, on a rock-shaft pivoted in the forked stud or spur, raises an arm secured to said rock-shaft in the slot or fork of said spur, and lifts the end of the spring free from said stud or spur, thus permitting the arm I to be raised for permitting the escape of the bundle. The rear arm H<sup>1</sup> being fixed, however, serves as a fulcrum, upon which the bundle is turned up on end, and thrown over upon the dumping-tray at the rear of the binders' stand, this movement being produced by the rotation of the compressing-arm J<sup>1</sup> with the shaft J after the grain has been bound. The arms J<sup>1</sup> perform the double function of compressing the gavel and holding it in convenient form to be bound, and then of discharging the same, as described. An arm, *k*, on the shaft J, passing a spring-stop, *k*<sup>1</sup>, attached to the frame, serves to prevent any backward movement of the shaft and compressing-arms while the bundle is being bound. The shaft J is mounted in overhanging bars K connected with the elevator-frame, and is provided with a loose pulley, *k*<sup>2</sup>, to which motion is imparted by a belt from a pulley on the elevator-apron shaft, or from any other convenient pulley for the purpose. A sliding friction-clutch, *k*<sup>3</sup>, feathered to the shaft J, (see Fig. 5,) is moved into engagement with the pulley *k*<sup>2</sup> by the attendant or binder pressing with his foot upon a pivoted shipping-lever, L, when it is desired to rotate the shaft. The pulley and clutch are formed on their adjacent faces, the one concave, the other convex or hemispherical, for increasing their frictional grasp, the one upon the other, and when not held engaged by the lever L, are held out of contact by a spring, *k*<sup>4</sup>, applied between them, as shown in Fig. 5. Just underneath the arms H<sup>1</sup> H<sup>2</sup> H<sup>3</sup> is a table, M, which may be used in lieu of said arms as a receiving-table, if desired, but serving in this instance as an additional support therefor, said table being supported in front and rear by projecting bars M<sup>1</sup> attached to the elevator-frame. The rear end of the plank or table M has a longitudinal slot, *m*, cut in it, through which a transverse projecting bar, M<sup>2</sup>, is adjustably connected with it by a through-bolt or set-screw, *m*<sup>1</sup>. This bar M<sup>2</sup> is provided with angular brackets *m*<sup>2</sup>, in which is supported a transverse table-bar, N, to which the rear end of the band-table or binders' seat N<sup>1</sup> is attached, the forward end of said table being supported upon a bar, N<sup>2</sup>, resting in angular brackets connected with the forward bar M<sup>1</sup>. The brackets *m*<sup>2</sup> permit the bars N N<sup>2</sup> and table to slide in or out for diminishing the width of the machine, or for adapting the table N to hold the prepared bands, or to be used as a binder's seat or support. The slot *m*, in connection with a similar slot, *n*, in the table N, adapts the bars M<sup>2</sup> and

N to be moved forward, and with them an inclined chute, O, attached to the former for varying the position of the latter, over which the grain descends into the dumping-tray, to the adjustment of the rear arm H<sup>1</sup>, in adapting said arm to the length of the grain or straw operated upon. Angular rods P P', connected with the bars K, or to any other convenient point of support, either adjustably or rigidly, as preferred, serve to give direction to the movement of the bundle as it is being discharged by the rotation of the arms J<sup>1</sup>. These rods P P' are placed above the shaft J, and lie parallel therewith, in such manner that when the butt end of the bundle is raised it passes between said rods, and is by them prevented from being deflected laterally while being discharged, and is thus directed with precision to the inclined chute O, over which it passes to the bundle-carrier.

The arms J<sup>1</sup> are connected adjustably with the shaft J by sleeves or collars j', and set-screws, by means of which the arm nearer the forward end of the shaft may be set slightly in advance of the rear one, and by this arrangement made to facilitate the operation of "up-ending" and discharging the bundle. J<sup>2</sup> J<sup>2</sup> are adjustable hubs on the shaft J, which serve to hold the grain away from said shaft sufficiently to facilitate the operation of passing the band around the bundle by hand. Q is the binders' stand, supported and sliding in and out upon extensions of transverse main-frame bars. Said stand has bars Q' attached to it in front and in rear of the frame-bars, the bars Q' being slotted at q; and pins or bolts q' passing through said slots serve to limit the movement of the stand or support Q, while, at the same time, they prevent the support from tilting when drawn out into working position. The rear end of the sliding stand Q has a dumping tray or table, R, hinged to it, and at the sides of said table are fastened foot-plates r or irons forming supports for angular rails or rods s s', constituting stationary sides or guards around the tray. The upper one S extends around over the outer end of the tray and has an end board, R', hinged to it, said board being locked in position when the tray R is receiving the bundles by a pin, r', at its lower edge passing through a perforation in the outer edge of tray R, but which releases the board and allows it to swing outward when the tray is dumped. The inner or forward end of the tray overhangs the stand Q, and is provided at its inner side with a standard or spur, s, with which a spring-hook, t, engages for holding the tray in proper position to receive the bundles. The spring-hook t is withdrawn for releasing the tray, when it is desired to dump the bundles, by a cord, u, operated by the driver. A second cord, u', passing through suitable guides, and connected with the forward end of the dumping-tray, enables the driver to return the tray to proper position for receiving the grain after it has been dumped or tilted to discharge its

load. In Fig. 6 I have shown a deflecting-apron, arranged at the upper end of the elevator, for changing the direction of the grain and turning it outward toward the binders. Ordinarily this has been done by bending the ends of the compressing-wires, as shown in Figs. 1 and 2.

Where this grain is heavy these bent ends of the compressing-wires v sometimes tend to check the movement of the grain. To remedy this the compressing-wires are shortened, leaving only the straight portion which holds the grain to the apron in its upward movement, and at the upper ends of these retaining or compressing wires I place a short endless apron, W, extending across the upper end of the elevator and compressing-wires, and set obliquely thereto, as shown in Fig. 6, said apron moving outwardly on its under side on rollers w w, supported in standards W' connected with the elevator-frame. A pulley, x, on the end of the shaft of one of these rollers, may be operated by a band from a pulley on the elevator-roller shaft, or other convenient driving-shaft. The tongue or draft attachment may be connected either with the truck-bar or with the vibrating main frame, as preferred. When connected with the latter the pivotal support of the latter will require to be set farther back than where the draft is connected with the truck bar or frame, as in such case the tendency of the draft would be to lift the cutters.

Having now described my improvements, what I claim as new, and desire to secure by Letters Patent, is—

1. The truck-bar or frame A, supported in front and rear of the main frame C, in combination with the said main frame pivoted centrally to and vibrating upon said truck-frame, substantially as described.
2. The main frame C C', connected with the truck-frame A by means of the link c' and d, arranged and operating substantially as described.
3. The upright endless apron G, or its equivalent, arranged at the inner end of the platform, and operating substantially as described for moving the butts of the grain backward to clear the forward guard of the elevator, as set forth.
4. The combination, with the elevator and the compressing rods or wires v, of the deflecting-apron W, overhanging the grain-receiver and the upper end of the elevator, and operating substantially as and for the purpose set forth.
5. The concave grain-receiving arms or hooks adjustably secured to the inclined delivery board or chute H, substantially as described.
6. The receiving arm or hook H<sup>1</sup> extended outward and upward, and connected with the rod or shaft J, in combination with the arm J<sup>1</sup>, arranged and operating substantially as and for the purpose set forth.
7. The receiving and compressing arm H<sup>3</sup>,

provided with the jointed extension I, for releasing the bundle, arranged and operating substantially as described.

8. The compressing and discharging arms J<sup>1</sup>, made adjustable upon the rotating shaft J, and operating in combination with the receiving-arm and fulcrum H<sup>1</sup>, substantially as described.

9. The combination, with the jointed arm H<sup>3</sup>, of the locking-spring I<sup>1</sup> and the spur *i*, and tripping-slide *i*<sup>1</sup>, operated by a cam or projection on the shaft J, for releasing the jointed extension I, as set forth.

10. The rods or bars P, in combination with

the discharging-arm J<sup>1</sup>, for giving direction to the movement of the bound bundle in being discharged, substantially as described.

11. The adjustable inclined chute O, in combination with the adjustable receiving and compressing arm H<sup>1</sup>, substantially as and for the purpose set forth.

In testimony whereof, I have hereunto set my hand this 6th day of February, A. D. 1875.

JOHN H. ELWARD.

Witnesses:

WM. H. MINNIX,  
ALEX. MAHON.