

F. B. PRINDLE & J. T. KENNEDY.

Machine for Threading Wood Screws.

No. 165,367.

Patented July 6, 1875.

FIG. 1.

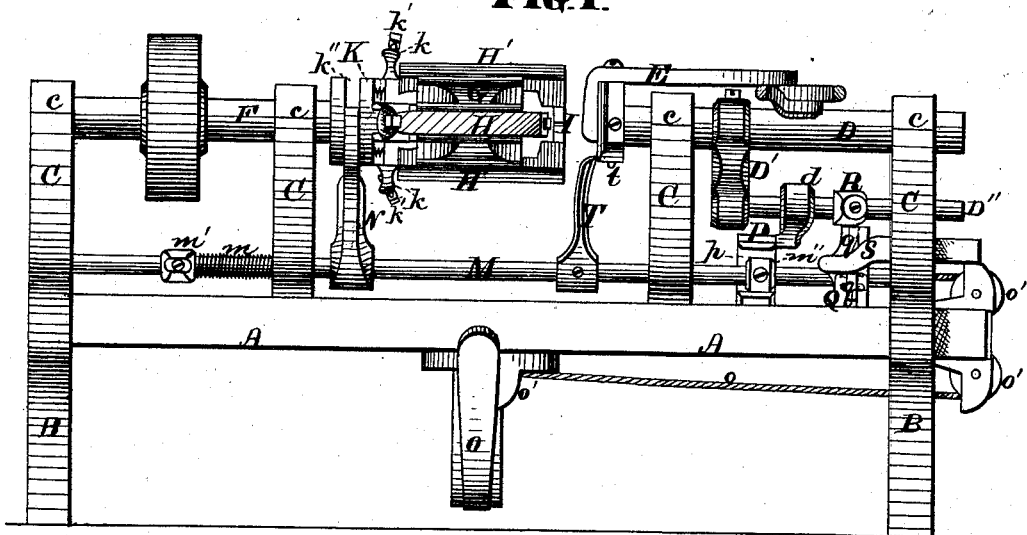
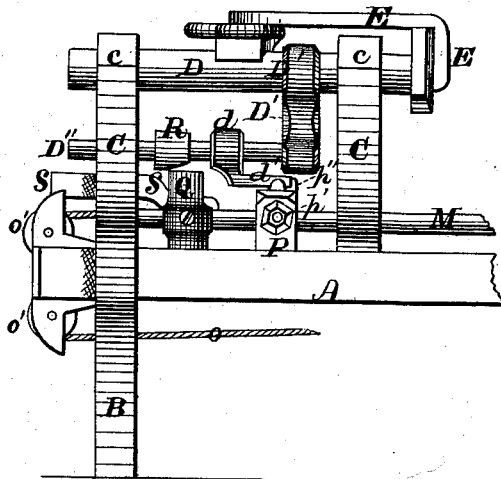

FIG. 2.



WITNESSES:

James Hutchinson
John A. Young

INVENTORS.

F. B. Prindle & John T. Kennedy,
by Prindle & his Attys

F. B. PRINDLE & J. T. KENNEDY.

Machine for Threading Wood Screws.

No. 165,367.

Patented July 6, 1875.

FIG. 3.

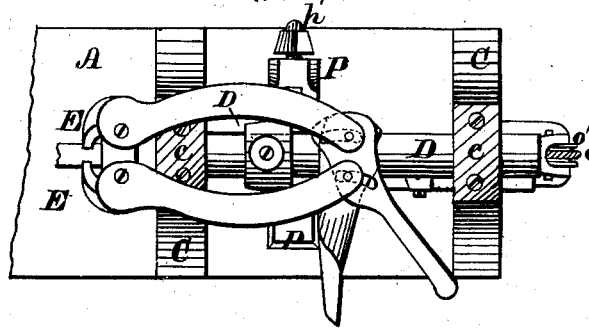

FIG. 4.

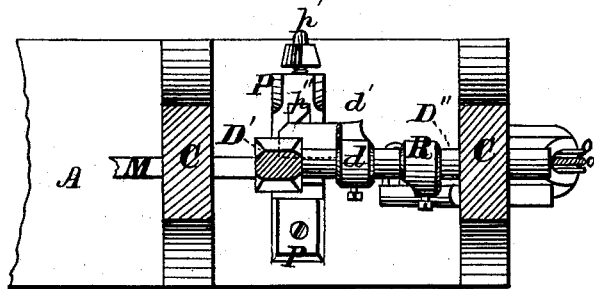

Fig. 6.

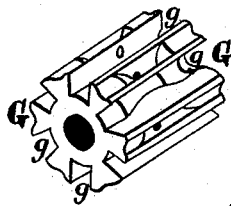
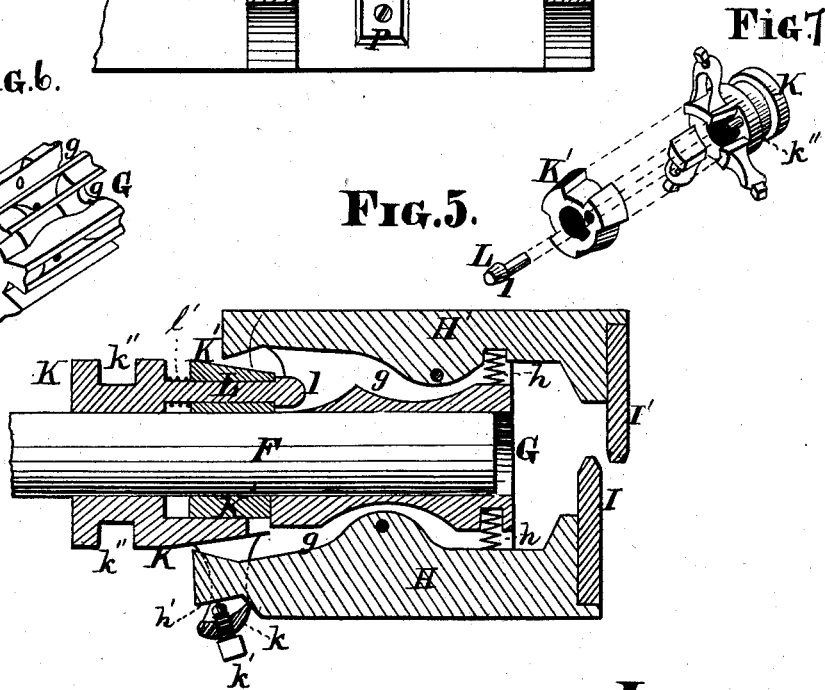

FIG. 5.



WITNESSES:

Jack Hutcherson
John R. Young

INVENTORS.

F. B. Prindle & Jno. T. Kennedy, by
Prindle & Co. their Attorneys

F. B. PRINDLE & J. T. KENNEDY.
Machine for Threading Wood Screws.

No. 165,367.

Patented July 6, 1875.

FIG. 8.

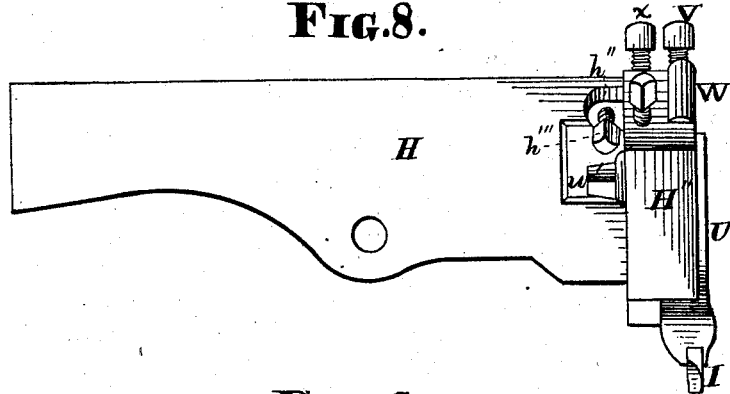

FIG. 9.

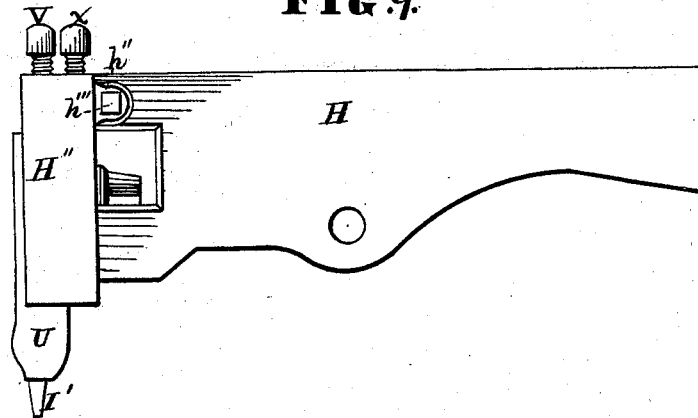

FIG. 10.

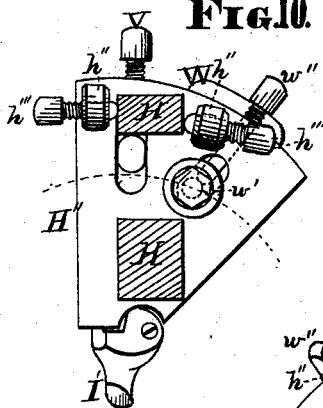

FIG. 11.

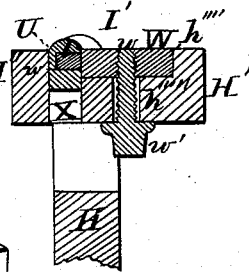
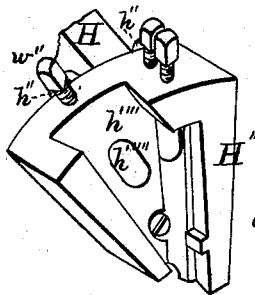

FIG. 12.



WITNESSES:

Jas. C. Hutchinson
John R. Young

INVENTORS.

F. B. Prindle and J. T. Kennedy
by Prindle and Co. their attys

UNITED STATES PATENT OFFICE.

FRANKLIN B. PRINDLE, OF SOUTHWINGTON, AND JOHN T. KENNEDY, OF MOUNT CARMEL, CONNECTICUT.

IMPROVEMENT IN MACHINES FOR THREADING WOOD-SCREWS.

Specification forming part of Letters Patent No. 165,367, dated July 6, 1875; application filed May 1, 1875.

To all whom it may concern :

Be it known that we, FRANKLIN B. PRINDLE, of Southington, Hartford county, and J. T. KENNEDY, of Mount Carmel, in the county of New Haven, both in the State of Connecticut, have invented certain new and useful Improvements in Machines for Threading Wood-Screws; and do hereby declare that the following is a full, clear, and exact description thereof, reference being had to the accompanying drawings making a part of this specification, in which—

Figure 1 is an elevation of the front side of our improved machine. Fig. 2 is a like view of the rear side of the tail end of the same. Fig. 3 is a plan view of the upper side of said end. Fig. 4 is a horizontal section of the same upon line *x x* of Figs. 1 and 2. Fig. 5 is an enlarged longitudinal central section of the rotating head employed for pointing and threading the screws. Fig. 6 is a perspective view of the head to which the cutter-heads are pivoted, separated from the latter. Fig. 7 is a like view of the cones employed for opening and closing the cutters. Figs. 8 and 9 are elevations of opposite sides of one of the cutter-heads. Fig. 10 is an elevation of the front end of the same, and Fig. 11 is a section upon line *z z* of Fig. 10.

Letters of like name and kind refer to like parts in each of the figures.

The design of our invention is to increase the facility with which wood-screws are made; and it consists, principally, in the combination of the revolving head, pivoted levers, and radially-moving threading and point-threading cutters, substantially as and for the purpose hereinafter specified. It consists, further, in the means employed for opening and closing the threading and point-threading dies, substantially as and for the purpose hereinafter shown. It consists, further, in the mechanism by which, in the order named, the threading-dies commence their operation, the point-threading dies follow, complete their work, and are then opened, after which said threading-dies, having completed their work, are also opened, substantially as and for the purpose hereinafter set forth. It consists, further, in the means employed for attaching the

cutters to, or within, the head, substantially as is hereinafter shown and described. It consists, further, in the means employed for adjusting the angle of the cutters, substantially as is hereinafter specified. It consists, finally, in the means employed for adjusting the point-threading cutters lengthwise of the screw, so as to cause them to enter the thread as commenced by the threading-cutters, substantially as and for the purpose hereinafter shown.

In the annexed drawings, A represents the bed or frame of our machine, resting upon, and supported by, suitable legs B B, &c., and having at each end, and at two points between the same, a vertical arm, C, which, at its upper end, is provided with a journal-box, *c*. Within the boxes *c* and *c*, at one end of the frame, is fitted a mandrel, D, which is arranged to slide longitudinally, but not to revolve, and is provided at its forward end with clamps E and E, for grasping the head of a screw, which clamps are operated by any suitable means when it is desired to confine within, or release from, the same a screw. Within the boxes *c* and *c*, at the opposite end of the frame, is journaled a shaft, F, which is caused to revolve by means of a belt-pulley placed midway between said boxes. Upon the inner end of the shaft F is secured a head, G, (shown in Fig. 6,) which is provided with six longitudinal radial grooves, *g g*, &c., that contain each a corresponding bar, H or H', which is pivoted at or near its longitudinal center, and has a certain degree of motion upon its pivotal bearing. Each alternate bar H' is pivoted nearer the forward end of the head G than the adjacent bars H and H, and has its forward end correspondingly advanced beyond the ends of the same, as seen in Fig. 5, while upon said end of each bar is secured a cutter, I or I', that operates either as a threader or pointer for a screw, those attached to the bars H' and H' performing the first-named office, while the cutters of the bars H and H form the point.

It is intended that the threading-cutters shall be closed upon the screw-blank and remain closed until the thread is completed, and that the point-threading cutters previously closed together shall commence operations as the threaded end of said blank leaves the first-

named cutters, and shall open as the end of said blank passes inward, so as to thread the same, after which said point-threaders, continuing to open, leave the screw, their operation being wholly within the time required for the completion of the work of said threading-cutters. To effect such result the following-described mechanism is employed: Fitted loosely upon the shaft F, in rear of the head G, is a cone, K, (shown in Fig. 7,) which is capable of longitudinal motion within certain limits, and when pressed forward will pass beneath the rear ends of the bars H and H', and, moving the same outward, will close inward the opposite ends of said bars and their cutters I and I'. A spring, *h*, placed between the bottom of the groove *g* and the forward portion of each bar H and H', causes the forward ends of the same to spread apart, except when forced together by the cone K; but in order that the outward movement of the said bars H' and H' may be rendered certain when their point-threading cutters are at work, the upper side at the rear end of each bar is provided with a rearward and outward incline, *h'*, and is contained within a slotted lug, *k*, that is secured upon and extends radially outward from said cone. A set-screw, *k'*, passing inward through the outer end of said lug *k*, bears upon the face of said incline *h'*, and, as said cone is moved rearward, forces the rear end of said bar H inward and correspondingly moves outward its forward end.

As seen in Fig. 7, the cone K is recessed at its front end, and receives a supplemental cone, K', which at three points (between the bearings for the bars H and H') extends outward through suitable radial slots, and completes the line of the periphery of said cone. Three studs, L L and L, provided each upon its outer end with a head, *l*, pass longitudinally inward through corresponding openings in the cone K, and, being secured at their inner ends to or within the cone K, serve as checks to limit the independent movement of the former away from the latter, while a spiral spring, *l'*, placed around each stud, between the inner end of said cone K' and the corresponding end of its recess, causes said cone to maintain its outward position unless forced rearward by a power greater than that of said springs. The cone K' bears against the rear ends of the arms H' and H', and, when moved forward, causes the threading-cutters I' and I' to close inward. When the cones K and K' are moved forward the latter maintains its advanced position until its forward end comes into contact with the rear end of the head G, when its motion in such direction is arrested, while said cone K continues to move until it, too, is similarly arrested. Upon reversing the operation of said parts the cone K will alone move rearward until the heads *l* of the studs L come into contact with the forward end of the cone K', after which said cones will move together to their rear position. The cones K

and K' are moved longitudinally upon the shaft F by means of a bar, M, which is placed below the latter, extends horizontally through suitable bearings the entire length of the frame, and is provided with a vertical arm, N, that is forked at its upper end, and at such point is contained within a groove, *h''*, that is formed within the rear portion of said cone K. The bar M is moved forward by means of a treadle, O, which is connected through a cord, *o*, and suitable pulleys *o' o'*, &c., with the front end of said bar, the arrangement being such as to cause the latter to be moved forward whenever said treadle is depressed. When the treadle O is released a spiral spring, *m*, coiled around the bar M, and having its ends confined between a collar, *m'*, secured upon said bar and one of the arms C of the frame, moves said bar and the cones rearward, and opens the threading and point-threading dies or cutters.

In order that the threading and point-threading dies may be automatically opened at the instant when they have performed their office the bar M is connected with the blank-holding mandrel D, so as to be released thereby by the following-described mechanism:

Upon the bar M, between the forward frame-arms C and C, is secured a collar, *m''*, which, as said bar moves forward and back, passes through a correspondingly-shaped recess, *p*, that is formed within a lug, P, attached to or upon the bed A. Within the lug P is provided a spring-pawl, *p'*, which, when the bar M has moved to the limit of its forward motion, is thrown into engagement with the rear end of the collar *m''*, and locks said bar in place. An arm, D', secured to and extending downward from the mandrel D, is attached at its lower end to or upon the front end of a bar, D'', which bar from thence extends outward through a suitable bearing in the end frame-arm C. From the bar D'' an arm, *d*, extends downward, and at its lower end, which is directly over the lug P, is provided with a horizontal portion, *d'*, that extends inward, and has its rear side inclined or beveled near its inner end. From the pawl *p'* a stud, *p''*, extends vertically upward in such position as to engage with the inclined portion *d'* of the arm *d* as the latter is moved inward, said incline operating to move outward said stud and pawl, and release the latter from engagement with the collar *m''*.

It being necessary that the screw-blank should pass through the threading-cutters, and have its end in engagement with the point-threading cutters before the latter are permitted to commence to open, an arm, Q, is attached to the bar M near the forward frame-arm C, and, extending vertically upward, is provided with a spring-pawl, *q*, that may be caused to engage with a collar, R, that is secured to or upon the bar D'', said collar being placed in such position as to hold said pawl in a depressed position when the bars D and M are at the forward limit of their motion.

When the mandrel D moves forward, at the instant when the pawl p' is released by the arm d' , the collar R passes forward of the pawl q , and the latter rises and engages with the rear end of said collar, and prevents the bar M from moving forward with greater speed than that of said mandrel.

When the screw-blank has passed into the dies to a sufficient distance, the pawl q is released from engagement with the collar R by means of an arm, q' , that extends laterally outward from said pawl, and passes beneath an inclined bar, S, which latter depresses said pawl until the result named is produced.

An arm, T, secured to the bar M, and extending upward beneath the front end of the mandrel D, engages with a pin, t , that projects downward from the latter and carries said bar rearward, in the event of a failure of the spring m to perform its office.

The operation of the machine is as follows: The mandrel D is moved outward to its farthest limit, and a screw-blank clamped within its holding devices, after which the treadle is depressed until the rod M is moved to the limit of its forward motion and is locked in position. The treadle is now released, and the mandrel moved forward, so as to enter the end of the screw-blank within the threading-dies, when the latter will cause said blank and mandrel to move forward automatically as the thread is formed. By the time that the end of the blank has entered the point-threading dies, the shifting-bar M is released, and, moving rearward, causes said point-threading dies to open, after which the threading-dies, having performed their office, are opened, and the completed blank released, so as to be withdrawn.

As seen in Figs. 8, 9, and 10, a head, H'' , is pivoted to or upon the forward end of each bar H and H' , in such manner as to enable its upper end to be moved laterally upon and around its pivotal bearing, so as to adjust the end of the cutter I to the desired angle with relation to the periphery of the screw-blank. Two lugs or ears, h'' and h''' , project rearward from near the upper end of said head, and are each provided with a set-screw, h'''' , which extends inward, and has its inner end in contact with the side of the bar H. By withdrawing one of said screws and advancing the other, the position of said head can be readily changed, and when so adjusted is locked in place by causing both of said screws to bear firmly upon said bar. Within the face of the head H'' is formed a recess, h'''' , which, from its upper end downward, has a V shape, as seen in Fig. 12, and is slightly dovetailing from front to rear.

Within one side of the recess h'''' is placed a holder, U, for the point-threading cutter I', and between said holder and the opposite side of said recess is fitted a block, W, that corresponds to and fills said space, and is capable of vertical adjustment. A bolt, w , passing rearward through a slot, h''''' , in the head h'' , and pro-

vided upon its outer end with a nut, w' , prevents said block W from being moved outward from said head, while a set-screw, w'' , passing radially inward through the latter, and having its inner end in contact with the upper side of said bolt, enables said block to be moved in a like direction, so as to firmly clamp the cutter-holder U between its contiguous edge and the edge of the recess h'''' . The edge of the block W is beveled inward and rearward, so as to form for the cutter or die-holder U a dovetailed space, from which the latter cannot be moved outward without first breaking the bolt w or withdrawing radially said block. The tool-holder U is provided, within the side adjacent to the block W, with a parallel longitudinal groove, u , within which is contained the cutter I', said groove being of such transverse dimensions as to closely confine said cutter and, at the same time, permit it to be moved longitudinally by means of a set-screw, V, that passes radially inward through the outer end of head H' , and bears upon the end of said cutter.

In order that the position of the point-threading cutter I may be varied lengthwise of the screw being cut, so as to cause its cutting end to coincide with the thread already formed by the threading-cutters, the rear side of the holder U is inclined upward and forward and between such inclined face, and the rear side of the recess h'''' is placed a wedge-shaped bar, X, which is capable of being moved radially inward by a set-screw, x , that passes inward through a threaded opening in the head H'' , and bears upon the outer end of said bar.

As thus arranged, it will be seen that, by withdrawing the block W and advancing the bar X, the cutter-holder U will be moved forward, while, by reversing the motion of said parts, said holder will be moved rearward, the amount of variation thus obtained being equal to the distance between two threads upon a finished screw.

Having thus fully set forth the nature and merits of our invention, what we claim as new is—

1. In combination with the revolving head G, the pivoted bars H and H' and the radially-moving threading and point-threading cutters I' and I, respectively, substantially as and for the purpose specified.

2. In combination with the bars H' and H' , pivoted within the head G and carrying upon their forward ends the threading-cutters I' and I, the cone K' , fitted into and sliding longitudinally within a recess in the forward end of the cone K, having its forward motion limited by the headed studs L l, and caused to maintain such position by means of the springs l' and l'' , substantially as and for the purpose set forth.

3. In combination with the cones K and K' , the bar M, vertical arm N, collar m'' , spring-pawl p' p'' , bar D'' , arm d' d'' , arm Q, spring-pawl q q' , collar R, and inclined bar S, substantially as and for the purpose shown and described.

4. In combination with the holder U and with the head H'', provided with the recess h''''', the block W, fitted within said recess, held in place by the screw w and nut w', and caused to bear against said holder by means of the set-screw w'', substantially as and for the purpose specified.

5. In combination with the bar H and with the cutter-holder U, the head H'', pivoted upon the forward end of said bar, and rendered circumferentially adjustable by means of the set-screws h''' and h''', substantially as and for the purpose shown.

6. In combination with the holder U, fitted into the recess h'''' of the head H'', and held

in place by means of the radially-adjustable block W, the radial wedge-shaped bar X, fitted between the rear side of said recess and the inclined back face of said holder, and made longitudinally adjustable, substantially as and for the purpose set forth.

In testimony that we claim the foregoing we have hereunto set our hands this 28th day of April, 1875.

FRANKLIN B. PRINDLE.
JOHN T. KENNEDY.

Witnesses:

C. W. BLATCHLEY,
E. P. McLANE.