

E. SCHOENBERG.
Carbureting-Machine.

No. 165,372.

Patented July 6, 1875.

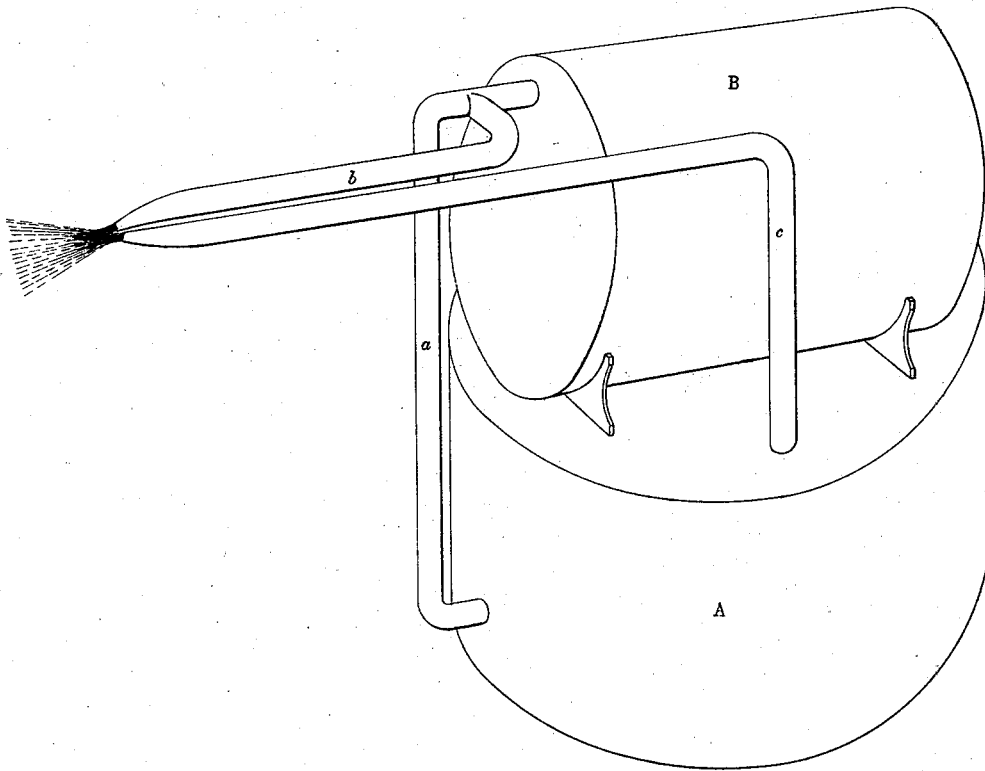

— WITNESSES —

Wm. H. Lawson
W. W. Wharton

— INVENTOR —

Emanuel Schoenberg
by G. H. N. Howard
his Atty.

UNITED STATES PATENT OFFICE.

EMANUEL SCHOENBERG, OF BALTIMORE, MARYLAND.

IMPROVEMENT IN CARBURETING-MACHINES.

Specification forming part of Letters Patent No. **165,372**, dated July 6, 1875; application filed June 17, 1875.

To all whom it may concern:

Be it known that I, EMANUEL SCHOENBERG, of the city of Baltimore, in the State of Maryland, have invented certain Improvements in Carbureting-Machines, of which the following is a specification, reference being had to the accompanying drawing forming a part hereof.

This invention relates to certain attachments to the air-forcing and carbureting chambers of the machine, whereby, in addition to the purposes of illumination, for which it is used, the machine may be employed for various heating purposes, as hereinafter described.

The accompanying drawing represents a perspective view of a carbureting-machine embodying my improvements.

A is the carbureting-chamber, surmounted by the air-forcing chamber B. The two chambers are united by the air-pipe *a*. To an upper portion of the air-pipe is connected an extra air-pipe, *b*; or the pipe *b* may lead directly from the air-forcing chamber. An extra gas-pipe, *c*, is secured to the top of the carbureting-chamber. The pipes *b* and *c* run together at their outer ends, as shown.

The forcing-wheel in the chamber B drives air through the gasoline contained in the carbureting-chamber, the air escaping from the pipe *c* in a carbureted condition, and being ignited at the point of escape. A volume of air not carbureted, or ordinary atmospheric air, is also driven through the air-pipe *b*, which unites with, and supplies with oxygen, the flame, thus intensifying its heat.

The heat thus obtained is designed for various uses, such as heating irons for employment in oyster or fruit packing establishments, &c.

Having described my invention, I claim as new and wish to secure by Letters Patent of the United States—

In combination with the air-forcing and carbureting chambers of a gas-machine, the extra air and gas pipes *b* and *c*, running together, as and for the purposes specified.

In testimony whereof I have hereto subscribed my name this 11th day of June, 1875.

EMANUEL SCHOENBERG.

Witnesses:

WM. T. HOWARD,
JNO. T. MADDOX.