

J. E. SMITH.
Printing-Telegraph.

No. 165,379.

Patented July 6, 1875.

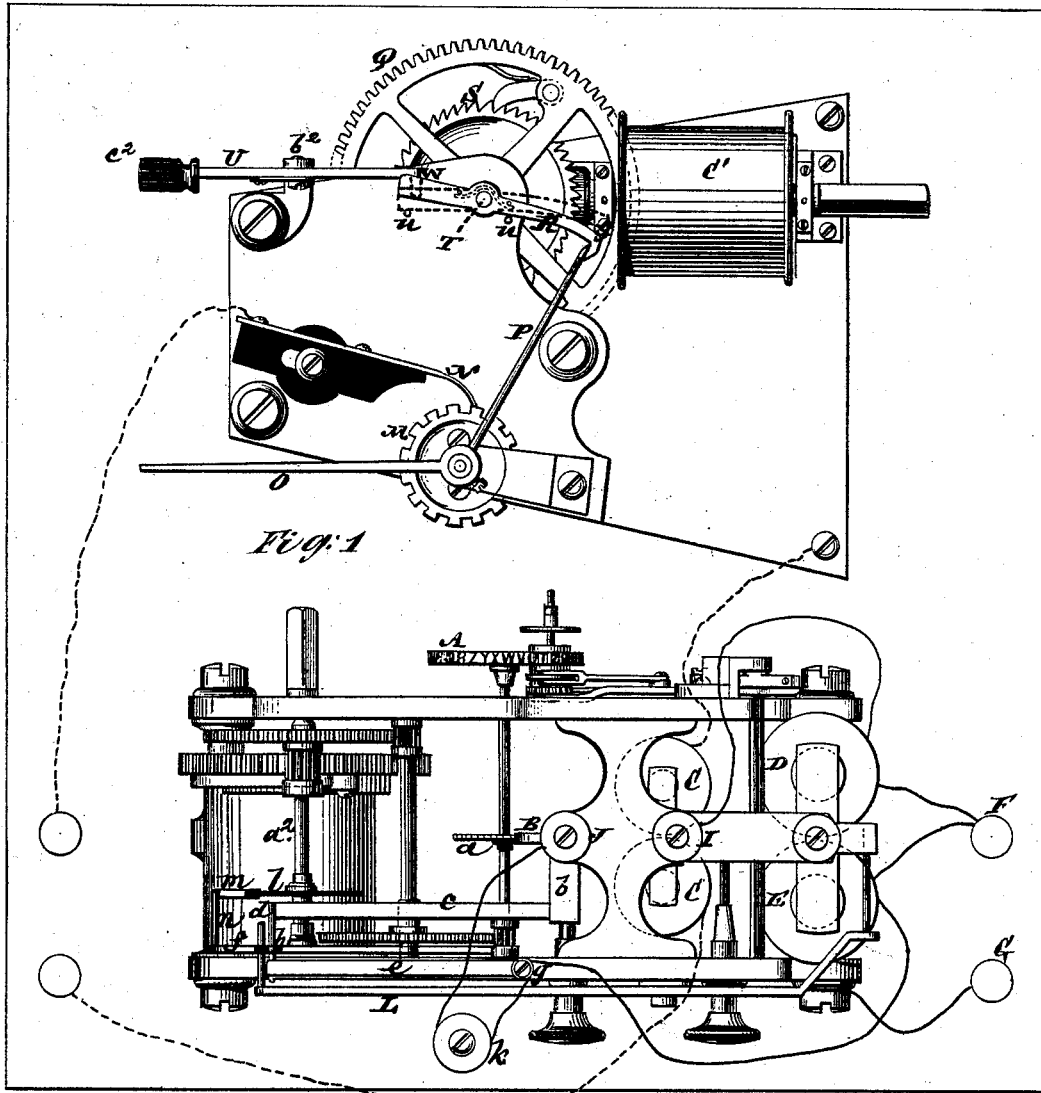

Witnesses:
Michael Ryan
Fred. Haynes

John E. Smith
by his Attorneys
Brown & Allen

J. E. SMITH.
Printing-Telegraph.

No. 165,379.

Patented July 6, 1875.

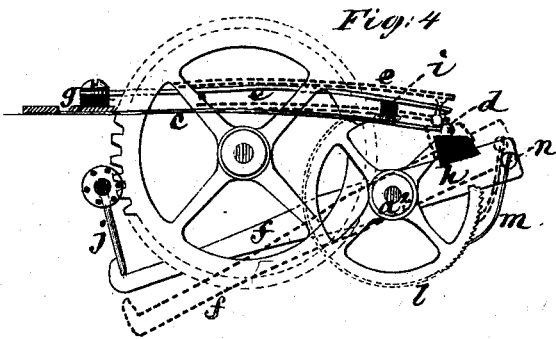
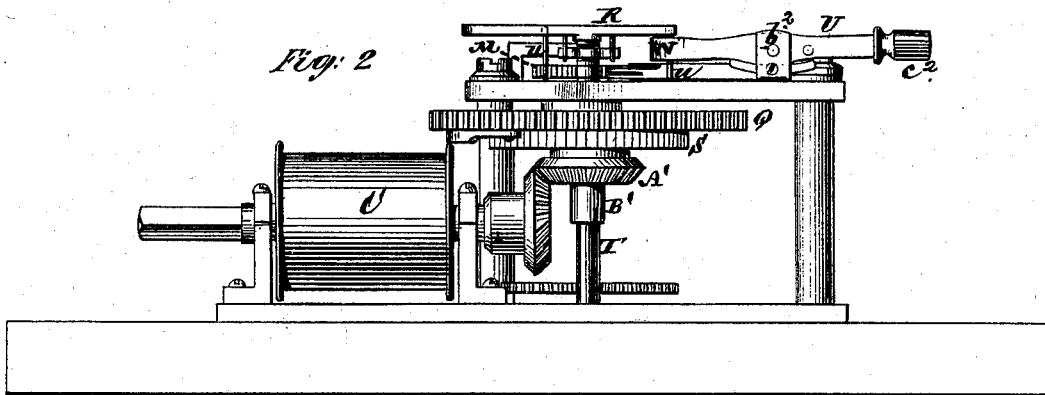
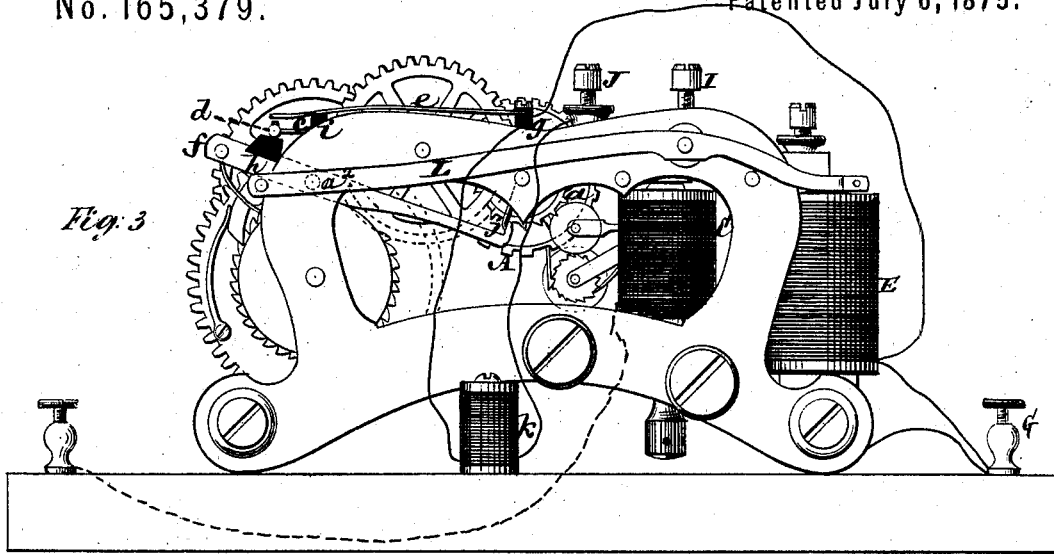

Fig. 5



Witnesses:
Michael Ryan
Fred. Haynes

John E. Smith
by his Attorneys
T. Brown & Allen

UNITED STATES PATENT OFFICE.

JOHN E. SMITH, OF NEW YORK, N. Y.

IMPROVEMENT IN PRINTING-TELEGRAPHS.

Specification forming part of Letters Patent No. **165,379**, dated July 6, 1875; application filed May 21, 1875.

To all whom it may concern :

Be it known that I, JOHN E. SMITH, of the city, county, and State of New York, have invented certain new and useful Improvements in Printing-Telegraphs; and I do hereby declare that the following is a full, clear, and exact description of the same, reference being had to the accompanying drawing, which forms part of this specification.

This invention relates to printing-telegraphs designed for use principally on short lines connecting offices, manufactories, and other business or private establishments.

One part of the invention consists in a novel arrangement of the escapement-lever of the type-wheel in the local printing circuit, whereby at each single vibration of said lever the circuit is closed through only one helix of the printing-magnet. By this arrangement one-half of the characters on the type-wheel are printed on a closed main circuit, and the other half of the characters on an open main circuit, thus effecting great rapidity of transmission.

Another part of the invention consists in an attachment to the clock-work and one branch of the local circuit of an electro-mechanical circuit-breaker, for automatically leaving the printing-circuit open, or introducing a resistance while the line is not in actual use, thereby greatly economizing battery expense.

The invention also consists in a device applied to the transmitter to make it self-locking, for more fully carrying out the part of the invention referred to in the next preceding paragraph.

Furthermore, the invention consists in various novel constructions and combinations of details for developing or applying the improvements above indicated.

In the accompanying drawing, Figure 1 represents a plan of the receiving and transmitting portion of a printing-telegraph constructed in accordance with my invention. Fig. 2 is a side view from the transmitting portion of the instrument, and Fig. 3, a side view from the receiving portion thereof. Fig. 4 is a side view of devices used in connection with the unison-lever for leaving the local circuit open or introducing a resistance-coil when the instrument is not in use to economize battery. Fig. 5 is a transverse section of the

hand-lever used to operate the locking-lever of the transmitter.

The receiving portion of the telegraph herein described has a train of wheels, driven by a weight or spring, for rotating the type-wheel A. On the type-wheel shaft is an escapement-wheel, *a*, which is liberated step by step by the vibration of a pallet, B, such vibration being effected by the action of an electro-magnet, C, which is situated in the line circuit, as shown by broken lines. The soft-iron armature of this magnet has the usual retracting spring. The escapement-wheel *a* has but half as many teeth as there are characters, or places for characters, on the type-wheel, so that at each single motion of the escapement-pallet B, in either direction, the type-wheel advances one whole character. The printing-magnet D E is in a local circuit, the wires of which are shown by full lines, but the current passes through only one helix at a time. The inner ends of the wires in both the helices D E connect with the binding-post F, and the other binding-post G connects by a wire with the frame of the receiving-instrument. These binding-posts are to be connected to a local battery in the usual manner. The outer end of the wire of helix D connects with an insulated-screw, I, with which the lever of the escapement-armature makes electrical contact whenever the main circuit is open, but when the main circuit is closed said lever forms electrical connection with an insulated-screw, J, which connects indirectly with the outer end of the wire of the helix E. Hence, it will be seen that as the escapement-pallet B oscillates to liberate the type-wheel train the local printing current is rapidly and alternately sent through the helices D and E; but as this arrangement of circuits causes the polarity of the printing-magnet to rapidly reverse during the revolution of the type-wheel, and as the printing-magnet is also larger and more sluggish than the one actuating the type-wheel escapement, the printing-lever will be moved only by a prolonged opening or closing of the main circuit, which prolongation is effected by arresting the motion of the transmitter in the usual manner.

As a current of considerable quantity is required to effect the printing, it is desirable

that the local circuit be left open, or a resistance-coil be introduced while the instrument is not in use, in order to economize battery. To accomplish this automatically, I place in the branch of the local circuit, which is closed by the closing of the main circuit, two springs or levers, and so combine them with the unison lever, or an independent lever having a like movement, that whenever the operator finishes sending, the instrument will automatically run to unison, and the two springs will separate and introduce a resistance into the local circuit, or leave it open as long as the main circuit remains closed. Thus a piece of metal, *b*, is clamped by and insulated with the screw *J*. A light flat metallic spring, *c*, extending from *b*, terminates with a wire or pin, *d*, running across and above the unison lever *f*, and beneath another light flat spring, *e*, which is also insulated from the frame at *g*. The pin *d* constantly presses against an insulating-piece, *h*, fastened to the upper part of the unison-lever *f*; but the spring *e*, just before the unison-lever, locks the type-wheel, is arrested in its downward movement by an insulating-piece, *i*, and separated from the spring *c*, thus breaking that branch of the local circuit in which the helix *E* is situated when no resistance-coil is used; but when one end of such a coil, *k*, is connected with the spring *e* and the other end with the spring *c*, or with the screw *J*, the current will flow through the coil *k* on the separation of said springs, and will be weakened in proportion to the amount of such resistance. It will be seen that, in this case, the springs *c* and *e* act simply as a shunt to the coil *k*. As it is claimed that the gravity form of sulphate of copper battery is kept in the best condition by constantly furnishing a feeble current, the resistance-coil may be attached, as described, whenever this kind of battery is employed as a local; but when other batteries are used the coil may be removed, when the separation of the springs *c* and *e* will introduce an infinite resistance or make an absolute break.

The unison-lever *f* is loosely fitted on the shaft of one of the wheels of the train, and locks the type-wheel by catching a pin, *j*, projecting from the type-wheel shaft, substantially as described in United States Letters Patent, No 127,111, granted to me May 21, 1872.

On the shaft *a*², which supports the unison-lever, is fastened a fine-toothed ratchet-wheel, *l*, into the teeth of which there catches a spring-pawl, *m*, connected to the unison-lever by a pin, *n*. This device prevents the spring *c* from constantly holding the unison-lever in a position to lock the type-wheel.

Every time a character is printed, the printing-lever, by depressing one end of the long lever *L*, causes the other end thereof to throw or operate the unison-lever and the springs *c* and *e*, as shown by dotted lines in Fig. 4; that is, the type-wheel is then unlocked and

said springs are in electrical contact with each other.

While the instrument is idle, the springs *c* and *e* and the unison-lever *f* are in the position indicated by whole lines in Figs. 3 and 4; that is, the type-wheel is locked at unison and said springs are separated, thus admitting a resistance-coil or breaking that branch of the printing-circuit which is operated by a closed main circuit. The parts are so proportioned that at every impression the springs *c* and *e* are raised so high that more than one complete revolution of the type-wheel is necessary to allow them to separate.

The type-wheel must be set to lock at unison on one of the characters printed on open main circuit. Then, in starting communication, the sender presses the corresponding key and starts the transmitter. This breaks the line-circuit and closes the local circuit through the helix *D*, when the printing-lever, by means of the lever *L* and the unison-lever *f*, unlocks the type-wheel and raises the spring *e* into contact with the spring *c*, the ratchet-wheel *l* and spring-pawl *m* holding the springs in contact until the instrument is again run to unison. In precisely the same manner another set of insulated springs, like *c* and *e*, may be made to let a resistance into the main circuit every time the machines come to rest, and thus diminish the consumption of the main battery.

The transmitter is purely mechanical. It consists, generally, of a train of wheels driven by a weight or spring for rotating a circuit-wheel, *M*, which operates the main circuit by intermittent contact of its teeth with an insulated spring, *N*.

Instead of the train of toothed wheels above referred to, a train of pulleys and bands may be used, inasmuch as it is immaterial what description of gear constituting the train be employed.

This circuit-wheel has the same number of teeth as the escapement-wheel *a*. Attached to the shaft of said circuit-wheel *M* is an arm, *O*, which is arrested in its rotation by the depression of the letter-keys in the usual manner. One of my improvements in this part of the instrument consists in the addition of an arm, *P*, to the shaft of the circuit-wheel arranged a little lower than the arm *O*, and the attachment to the shaft *T* of a more slowly-revolving wheel, *Q*, of a locking-lever, *R*. This lever is held only by the friction of a flat spring which presses into an annular groove in the shaft *T*, as in the case of unison-levers of other printing-telegraphs, said groove preventing the lever *R* from slipping off the shaft. Pins *u u* limit the motion of said locking-lever, which motion should be sufficient to require, say, four revolutions of the circuit-wheel to lock itself or one more than required by the printer, whatever the latter may be.

This transmitter locks itself in precisely

the manner that the printer does, excepting that no magnet takes part in the action of the former.

U is a lever pivoted at b^2 , and which has a beveled projection, W, (see Figs. 1, 2, and 5,) arranged so that the depression of the end e^2 of said lever causes the beveled end or projection W to press against the lever R, for the purpose of unlocking the transmitter and preventing its locking while in use.

When communication is finished the sender raises the end e^2 of the lever U, which liberates the locking-lever R. The circuit-wheel will then make, say, four revolutions, when the lever R will catch the arm P and arrest further motion of the transmitter. In the meantime all the printers in circuit will have been locked at unison, and their local circuits broken or resistances introduced. Thus the running of the printers to unison and leaving the local circuits open are not dependent on the care or memory of those using the instruments.

In Fig. 1 the position of the lever R, when the instrument is idle, is shown by full lines, and by dotted lines when it is held by the lever U while the transmitter is in operation.

The wheel Q is fast on its shaft T, but the ratchet-wheel S and the beveled wheel A' on a sleeve, B', turn freely on the shaft T. Thus the drum C', to which the motor spring or weight is applied, may be wound up without unlocking the transmitter and setting it in motion.

I claim—

1. In a printing-telegraph, the arrangement of one-half or portion of the wire of the printing-magnets in one local circuit or branch of a local circuit, and the other half or portion of the wire of said magnets in another local circuit or branch of a local circuit, in combina-

tion with a circuit-breaker that acts, during the rotation of the type-wheel, to open and close the circuit or circuits alternately through the two parts of the printing-magnet, substantially as set forth.

2. In a printing-telegraph, a printing-magnet in a local circuit or circuits, a type-wheel magnet in a main circuit, and an escapement-wheel that allows the type-wheel to advance a whole character at a single movement of the escapement-pallet, in combination with a lever that serves the double purpose of liberating the type-wheel and closing the local printing-circuit, to effect an impression by either a prolonged opening or closing of the main circuit.

3. In a printing-telegraph, the ratchet-wheel l and the pawl m , in combination with the lever f , substantially as described.

4. The springs c and e , in combination with an electro-magnet and a train of wheels for letting into an electric circuit a resistance either measurable or infinite.

5. The magnet C, pallet B, springs c and e , resistance k , lever f , ratchet-wheel l , and pawl m , in combination with a train of wheels, substantially as set forth.

6. In the transmitter of a printing-telegraph, the combination, with a train of wheels, of the arm P and the loosely-fitted lever R, substantially as and for the purposes set forth.

7. The lever U, in combination with the lever R, substantially as set forth.

8. In printing-telegraph apparatus, a self-locking transmitter, in combination with a self-locking printer.

J. E. SMITH.

Witnesses:

MICHAEL RYAN,
FRED. HAYNES.