

M. TOULMIN. Ellipsograph.

No. 165,385.

Patented July 6, 1875.

Fig. 1.

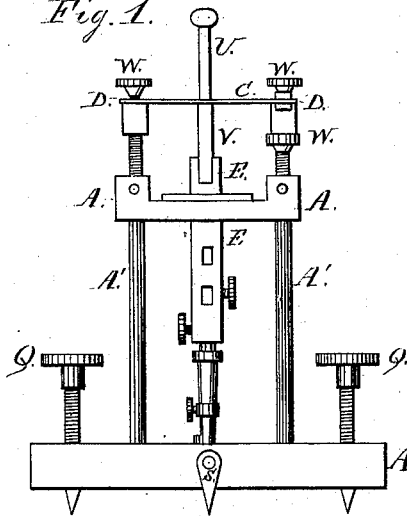

Fig. 2.

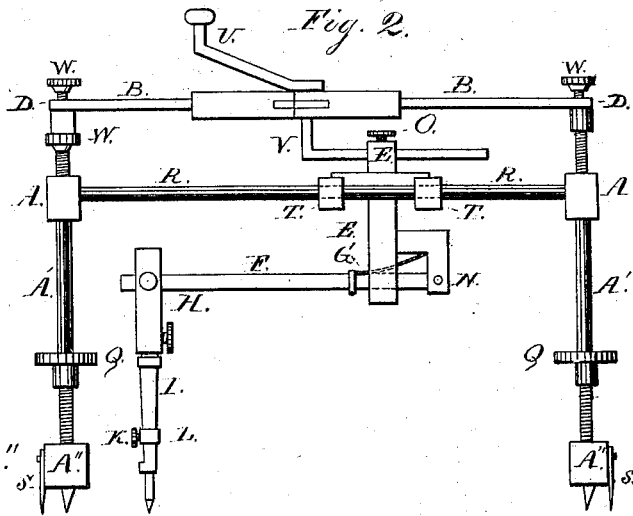

Fig. 3.

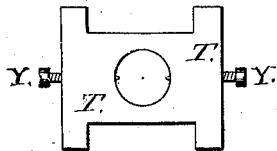

Fig. 4.

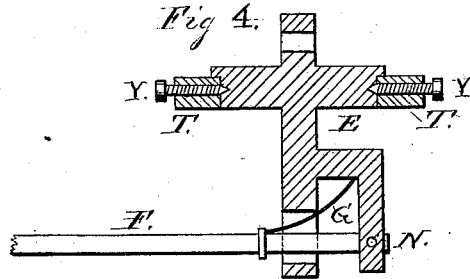
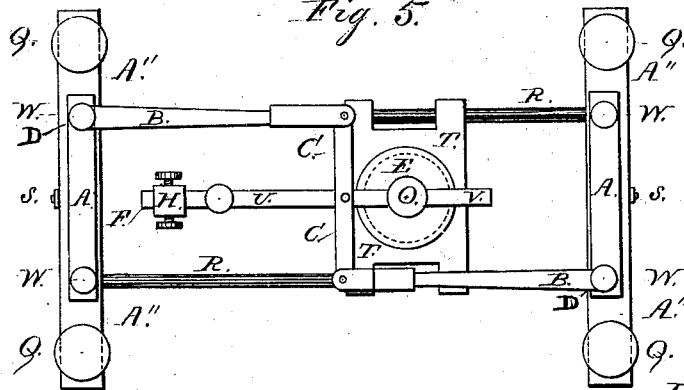

Fig. 5.



Witnesses.

H. Aubrey Tutmin
Albert S. Hall

Inventor.

Morton Toulmin

M. TOULMIN.
Ellipsograph.

No. 165,385.

Patented July 6, 1875.

Fig. 6.

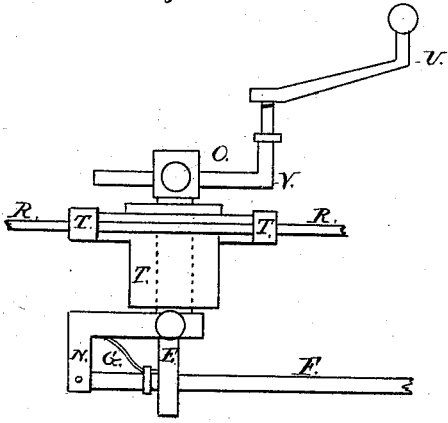

Fig. 7.

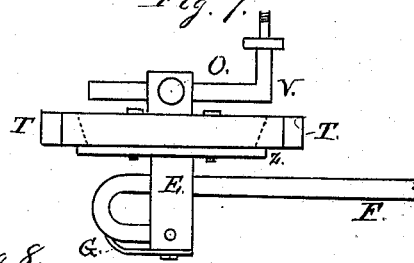

Fig. 8.

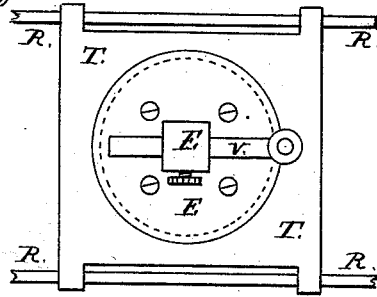

Fig. 9.

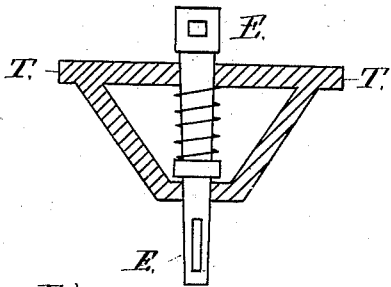

Fig. 10.

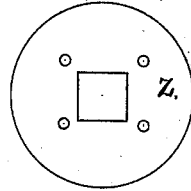

Fig. 11.

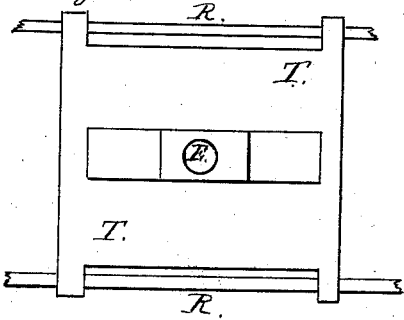
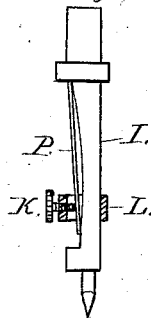

Fig. 12.



Witnesses.

H. Aubrey Toulmin

Albert S. Hall

Inventor.

Morton Toulmin

UNITED STATES PATENT OFFICE.

MORTON TOULMIN, OF WASHINGTON, DISTRICT OF COLUMBIA.

IMPROVEMENT IN ELLIPSOGRAPHS.

Specification forming part of Letters Patent No. **165,385**, dated July 6, 1875; application filed June 22, 1875.

To all whom it may concern:

Be it known that I, MORTON TOULMIN, of the city of Washington, District of Columbia, have invented an Ellipsograph, of which the following is a specification:

The object of my invention is to make a simple and efficient instrument for the construction of ellipses of various sizes and shapes, either in pencil or in ink.

The nature of the invention consists in the production of a simultaneous rotary and reciprocating motion to a vertical spindle or shaft, to which is attached a horizontal bar, which bar is furnished with means of attaching a pen or pencil-point.

The vertical shaft passes through an annular opening in a metal slide or carriage. This carriage slides freely to the right or left at the same time that the shaft is rotated. These two movements are obtained at the same time by the combined action of a crank and three pieces of metal, hereinafter described. The movement is a peculiar one, and causes the end of the pen or pencil bar to describe the desired ellipse.

In the annexed drawings forming a part of this specification, Figure 1 is an end elevation of the ellipsograph. Fig. 2 is a side elevation. Fig. 3 is a plan of the slide or carriage T. Fig. 4 is a sectional view of the shaft E, slide T, pen and pencil bar F, and spring G. Fig. 5 is a plan. Figs. 6, 7, 8, 9, 10, and 11 are modifications of some of the details. Fig. 12 is a detail view of the pencil-holder.

A A' A'' represent the end pieces of the ellipsograph. They can be made of wood or metal, and of a single piece, either cast or stamped out of sheet metal. R R are slide-rods, preferably made of steel. The ends of the rods R R are inserted in openings in the end frames A, either permanently or may be held in position by the binding-screws W. In this latter construction there may be several sets of rods to increase or diminish the scope of the instrument by removing one set and inserting another. The slides may vary in construction and in section, as a good many forms of slides will accomplish the object in view. T is a slide-frame or carriage. There are various forms in which it may be constructed. It has an annular opening in its center, in

which the shaft or spindle E rotates at the same time that the slide T slides backward and forward upon its slide-bars R R. The shaft E is held in its place by two or more pointed screws, which enter a groove in its periphery, or by a collar, which I prefer. Y Y are these screws. E is the shaft or spindle. It has an opening through its axis near its upper extremity, and another near its bottom extremity, and is also furnished with an arm projecting from one of its lower sides, and in a line with the above-named openings. Through the upper opening there is inserted a crank, U V. This crank slides through the upper opening, and may be shortened or lengthened and held fast in any position by the binding-screw O; or it may be moved backward and forward by a micrometer-screw or rack and pinion. The pen and pencil bar F passes through the lower opening in the shaft E, which acts as a guide, and is pivoted to the arm N, and is furnished with a spring, G, which should be just strong enough to hold the pen or pencil point down upon the paper and cause them to draw distinct lines. H is a slide, which slides to any part of the bar F between E and its outer end. It is furnished with two binding-screws, one of which to fasten it at any part of the bar F, and the other to retain the pen or pencil holder in the socket at its lower extremity. A'' of the end pieces are furnished with four adjusting-screws, Q, having pointed ends, to prevent the instrument from slipping and to level it, and also with two points, S, which enable the operator to set the instrument exactly over the place where the ellipse is to be drawn. B B are two bars, which should be exactly of the same length. They are pivoted at the two points D on the opposite diagonal corners of the frames A, and also to a middle bar or plate, C. The pivot-holes in the two bars B B must be exactly the same distance apart. C is a middle bar or plate, and is furnished with three pivot-holes, one in the center and one on each end. The holes in the ends must be exactly the same distance from the one in the center. The upper end of the crank V passes through the central hole of the plate C, and the inner ends of the bars B B are pivoted to the ends of the bar C. U is the upper crank, and is attached to the upper part of the crank V.

When the crank U is turned it causes a rotary movement to the shaft E, and at the same time a reciprocating motion to the carriage T, while the motion of the center of the plate C is exactly at right angles to the two slides R R. These three simultaneous motions cause the end of the pen-bar F to move in the line of an ellipse. When the crank V and the bar F are in the relative positions shown in the drawing the conjugate diameter of the ellipse is increased by shortening the crank V, and decreased by lengthening the crank V; but if the bar F is on the opposite side to that shown in the drawing the above alterations in the crank V would have to be reversed to produce the same results.

When the crank V and the bar F are in the position shown in the drawing the axis of the conjugate diameter of the ellipse will be exactly on a line with the points S S; but if the relative position of the crank V and the bar F are changed, so that the bar F is still on a line with the crank, but extending in the opposite direction, the axis of the transverse diameter will then be on a line with the points S S; but should the bar F be placed at right angles to the crank the transverse axis of the ellipse will then be in a diagonal line to the slide-bars R R.

In experimenting with this instrument I have placed one rod, R, over the other, and have used a crank and simple pitman, (but this does not give a true ellipse,) and have also used an eccentric.

I do not confine myself to the exact devices shown in the drawing, as they might be varied without departing from my invention.

In Drawing No. 2 I show some modifications of the different details.

Having described my invention, I claim and desire to secure by Letters Patent—

1. The end pieces A A' A'', in combination with the slide-rods R R, carriage T, sliding thereon, and supporting the pen-bar F, substantially as described, and for the purpose set forth.

2. The pointers S, as described, and for the purposes set forth.

3. The arms B B, middle plate C, and cranks V and U, pivoted together, and at the points D D combined with adjustable shaft E, arm F, and pen-holder H, substantially as described, and for the purposes set forth.

4. The slide T, having an annular opening in its center, substantially as described, and for the purposes set forth.

5. The vertical shaft E, with its horizontal bar F, with the spring G, substantially as described, and for the purposes set forth.

6. The slide-rods R R, in combination with the carriage T, cranks V and U, bars B, binding-screw O, pivots D, center plate C, vertical shaft E, and horizontal pen-bar F, and pen-holder H, substantially as described, and for the purposes set forth.

7. The arms B B, pivoted to the plate C, and to A'' at D, adjustable shaft E, having arm F, crank V, slide T, and bars R R, as and for the purposes described.

MORTON TOULMIN.

Witnesses:

ALBERT G. HALL,
H. A. HALL.