

L. W. TRACY.
Device for the Manufacture of Printers' Leads.
No. 165,387. Patented July 6, 1875.

Fig. 1.

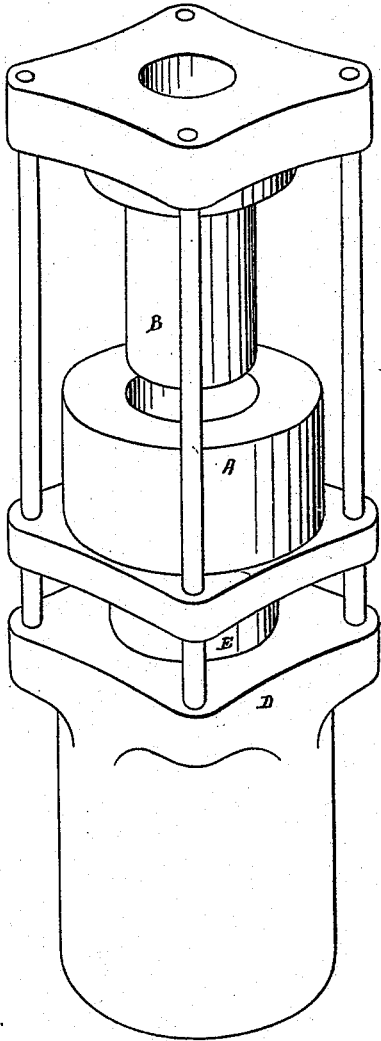

Fig. 2.

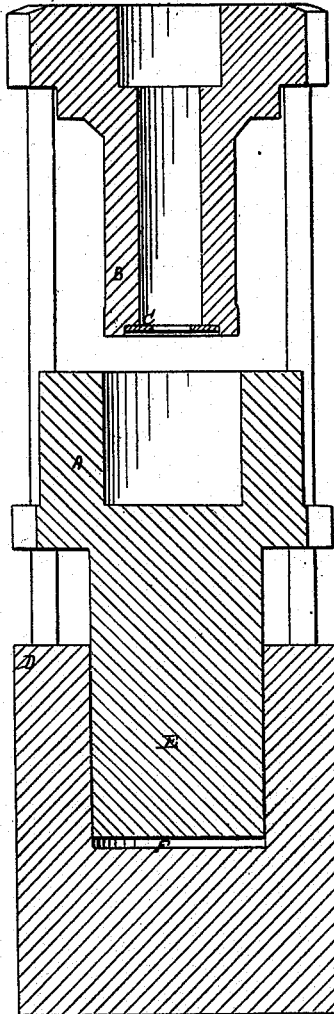

Fig. 3.



Witnesses:

Emmasick
John G. Lind

Inventor:

L. W. Tracy
by atty. Poush & Bailey

L. W. TRACY.
Device for the Manufacture of Printers' Leads.
No. 165,387. Patented July 6, 1875.

Fig. 1.

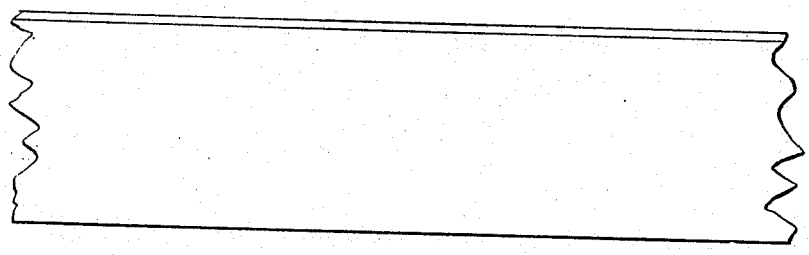

Fig. 2.



Witnesses:
Edw. W. Donn
Myhand

Inventor:
L. W. Tracy
Paul & Bailey
attys

UNITED STATES PATENT OFFICE.

LEWIS W. TRACY, OF BROOKLYN, ASSIGNOR TO THE SHAW & ROGERS LEAD COMPANY, OF NEW YORK, N. Y.

IMPROVEMENT IN DEVICES FOR THE MANUFACTURE OF PRINTERS' LEADS.

Specification forming part of Letters Patent No. **165,387**, dated July 6, 1875; application filed May 20, 1875.

To all whom it may concern:

Be it known that I, LEWIS W. TRACY, of Brooklyn, Kings county, New York, have invented a certain new and useful Improvement in Devices for the Manufacture of Printers' Leads, of which the following is a specification:

Printers' leads have heretofore been made either by casting in molds, or by rolling the metal in sheet form and then cutting up the sheet into desired widths. Under both of these methods the edges of the leads require to be planed beveling before they are ready for use; but even a greater objection is the inequality of thickness, which is a noticeable defect in leads thus made, and one which it is not practicable to effectually remedy under the methods of procedure above noted. These objections I obviate by forcing the metal or alloy, preferably in a semi-fluid or pasty condition, through a die-opening of the same size and shape as the lead is required to be in cross-section.

This operation can be performed with apparatus similar to the ordinary lead-pipe machine or press, excepting that the die should have the configuration above specified instead of that required for making pipe, and further that the core-piece is dispensed with.

One form of such press is represented on Sheet 1 of the accompanying drawing.

Figure 1 is a perspective view, and Fig. 2 is a vertical central section, of the apparatus. Fig. 3 is a view of the die detached.

A is the lead-containing cylinder, which, in this instance, is movable. B is the stationary hollow plunger, with its lower end closed by the die C, of a shape and size to form the required lead. The plunger is connected to the base D by stay-rods, on which the cylinder slides. The cylinder terminates in a piston,

E, which works in a cylinder, F, in base D. The cylinder F is in proper communication with some source of steam or water supply, by which, when desired, the lead-cylinder can be forced up toward the plunger.

Under my improvement the lead issues from the die in the form of a continuous strip, of the shape and size required for the completed lead, and with perfect and finished edges. As this strip passes from the machine, the leads are cut from it of any length desired.

A piece of such a strip is represented on an enlarged scale in plan and transverse section in Figs. 1 and 2, Sheet 2, of the accompanying drawing.

This mode of manufacture possesses numerous advantages over that hitherto practiced. I obtain perfect uniformity of thickness, the metal is rendered stronger and more pliable, the surfaces are perfect, and the cost of manufacture is lessened.

I would state in conclusion that it is immaterial for the purposes of my invention whether the cylinder moves toward the plunger or the plunger toward the cylinder; also, whether the die be carried by the plunger or by the cylinder.

What I claim as my invention, and desire to secure by Letters Patent, is—

The combination, with the metal-containing cylinder and the piston or plunger, of the die having the structure and configuration specified, when used in the manufacture of printers' leads, in the manner set forth.

In testimony whereof I have hereunto signed my name this 15th day of May, A. D. 1875.

LEWIS W. TRACY.

Witnesses:

R. A. PIPER,
B. F. LEE.