

E. BENJAMIN.  
Re-Sawing Machine.

No. 165,436.

Patented July 13, 1875.

Fig. 1.

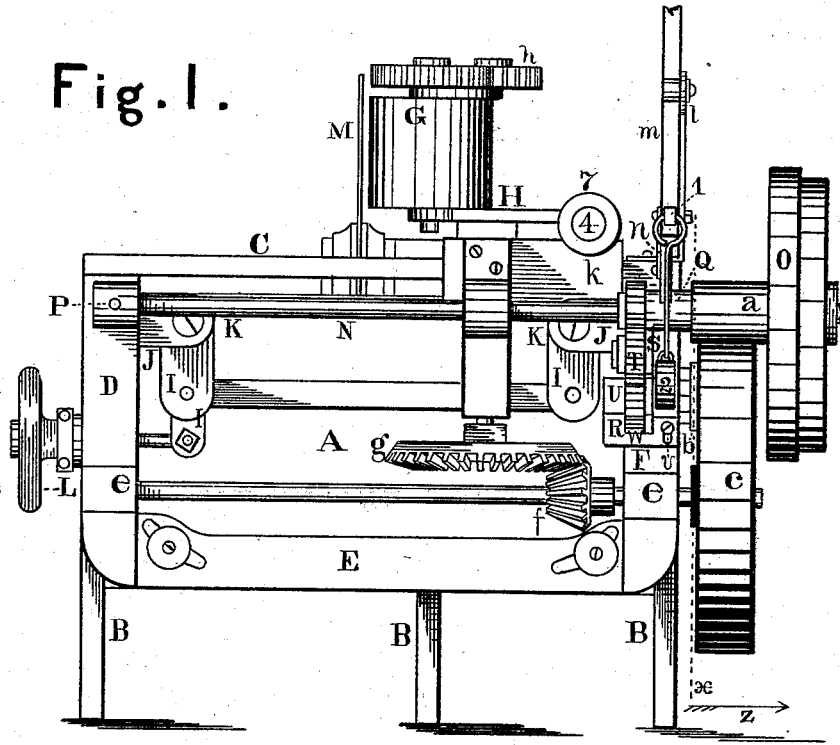
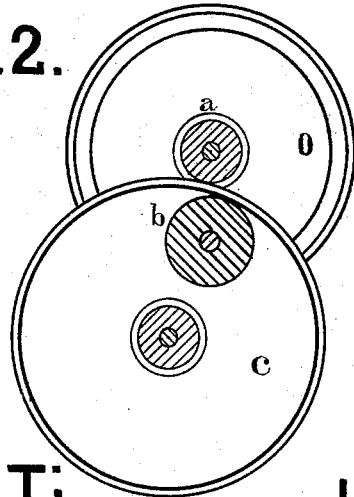

Fig. 2.



ATTEST:

*John N. Elliott*  
*Noratio S. Wait*

INVENTOR:

*Edwin Benjamin*  
*By G. P. Chapin*  
*Atty.*

E. BENJAMIN.  
Re-Sawing Machine.

No. 165,436.

Patented July 13, 1875.

Fig. 3.

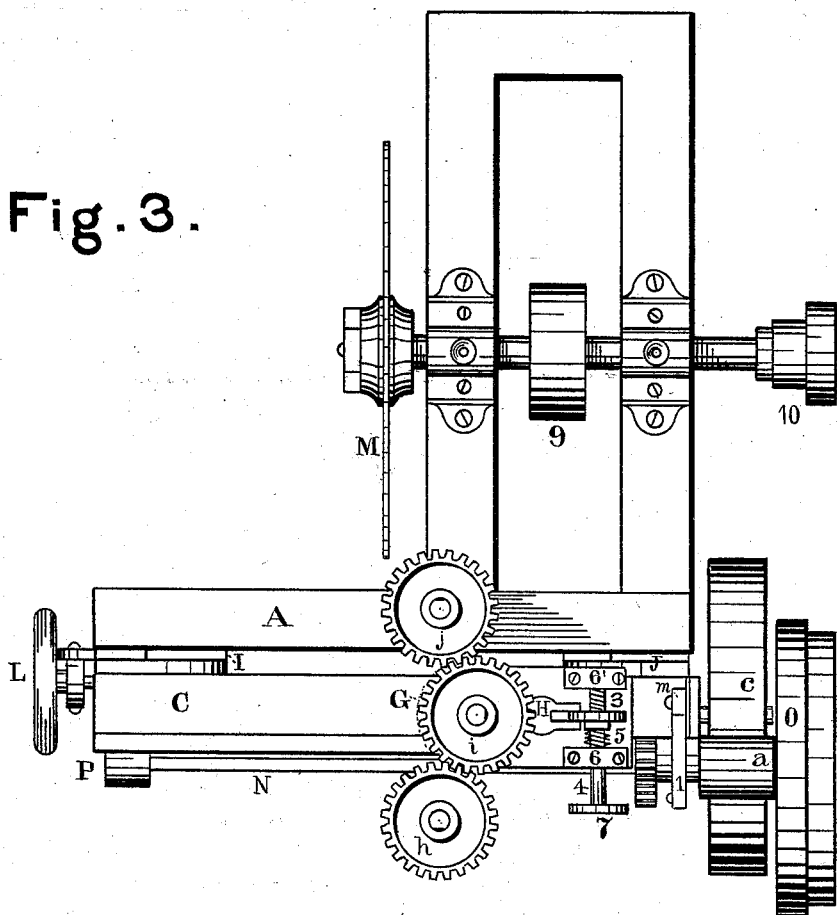

Witness:

*John N. Elliott.*  
*Koratio Swain*



Inventor:

*Edwin Benjamin,*  
*By G. C. Chapin*  
*Atty.*

# UNITED STATES PATENT OFFICE.

EDWIN BENJAMIN, OF CHICAGO, ILLINOIS.

## IMPROVEMENT IN RESAWING-MACHINES.

Specification forming part of Letters Patent No. **165,436**, dated July 13, 1875; application filed December 19, 1874.

*To all whom it may concern:*

Be it known that I, EDWIN BENJAMIN, of the city of Chicago, in the county of Cook and State of Illinois, have invented a new and useful Improvement in Resawing-Machines, of which the following is a specification:

The nature of the present invention consists in the combination of a friction back-gear with the feed-gear and an internal gear, whereby stuff to be resawed may be run rapidly back from the saw in case of accident or otherwise, a lever attachment being used to reverse the feed or take off the feed at will.

In the drawing, Figure 1 is an elevation of a resawing-machine embodying my invention; Fig. 2, a sectional elevation thereof on line *x x*, Fig. 1, looking in the direction indicated by dart *z*; Fig. 3, Sheet 2, a top or plan view of the improved machine.

A B represent a substantial frame of suitable form, for supporting the mechanism shown and hereinafter described. C D E F is the tilting frame, which supports the feed-rollers G and their attaching-plate H. The means for hanging this frame to the supporting-frame A consist of elbows I J, which turn on pivot-bolts K K when operated upon by an adjusting-screw, L, so as to give to the feed-rollers G any desired pitch relative to the plane of the saw M.

I do not claim to have invented the tilting frame, but confine myself to the means described and shown for hanging it.

N represents a shaft, which is supported by a box, P, at one end, and by a box, Q, at the other. The box Q is cast solid to or is a part of a plate, R, and supports a bearing, S, for receiving the pivot of a cog-gear, T. The plate R supports bearings U of a cog-gear, W, and is arranged, by means of one or more slots and bolts, V, to have a short vertical reciprocating movement for reversing the feed, as hereinafter described. The shaft N supports a friction-pulley, *a*, and a band drive-pulley, O, and the shaft of the cog-gear W supports a friction-pulley, *b*, Figs. 1 and 2. *c* represents an external and internal friction-wheel, which is hung in bearings *e e* in the

tilting frame C D E F, and supports a bevel-gear, *f*, meshing into a spur-wheel, *g*, which, by means of cog-gear *h i j*, drives the feed-rollers G. The shaft of the wheel *g* is supported by a sliding table, *k*, which is arranged to be moved to or from the saw M, the long bevel-gear *f* permitting the spur-wheel *g* to move some little distance without slipping the gear when in use. On the top of the bed part C is attached a standard, *l*, to which is pivoted a lever, *m*, provided with a connecting plate or rod, *n*, which is pivoted to the bearing Q of the shaft N, and the lever is provided with an arm, 1, which is weighted to bring the friction-pulley *a* on the periphery of the wheel *c*.

The arrangement of this lever and gearing is such that when the weight 2 controls the lever the pulley *a* drives the wheel *c* in the proper direction to feed stuff to the saw M, and when the lever *m* is moved back it operates to bring the friction-pulley *b*, Figs. 1 and 2, against the internal periphery of the wheel *c*. The feed-rollers G will be turned rapidly back, and carry a board from the saw.

By giving the lever *m* a medium position the wheel O will run without turning either of the pulleys *a b*. The pulley *b*, in practice, may be larger than the pulley *a*, so that the backward movement of the rollers G may be the quickest.

To bring the feed-rollers G to any desired angle relative to the plane of the saw a collar, 3, is placed on a shaft, 4, which is provided with a spring, 5, placed between the collar and one of the bearings, 6, of shaft 4, so that the collar may yield and allow the rollers G to permit uneven stuff to be fed to the saw without injury to the machinery. The shaft 4 enters the bearing 6 by means of a screw-thread, so that by turning the thumb-nut or wheel 7 the collar 3, fitting in the bed-plate H, will swing the plate on its axis, which is the shaft of spur-wheel *g*. The saw is driven by means of a band on pulley 9, in the ordinary manner, and the wheel O is driven by a band running from the wheel 10 on the same shaft as the wheel or pulley 9.

I here state that resawing-machines are old and well known; therefore I confine myself to the parts and combinations claimed.

I have described mechanism which in some respects is old, better to enable a machine to be built.

I claim as new and desire to secure by Letters Patent—

The lever *m*, with its weighted arm 1, in

combination with the friction-rollers *a b*, wheel *c*, pulley *O*, slotted plate *R*, and gear *T g W f*, as and for the purpose set forth.

Signed the 15th day of December, 1874.

EDWIN BENJAMIN.

Witnesses:

JOHN H. ELLIOTT,  
G. L. CHAPIN.