

G. BONKER.
Exhaust-Mechanism.

No. 165,437.

Patented July 13, 1875.

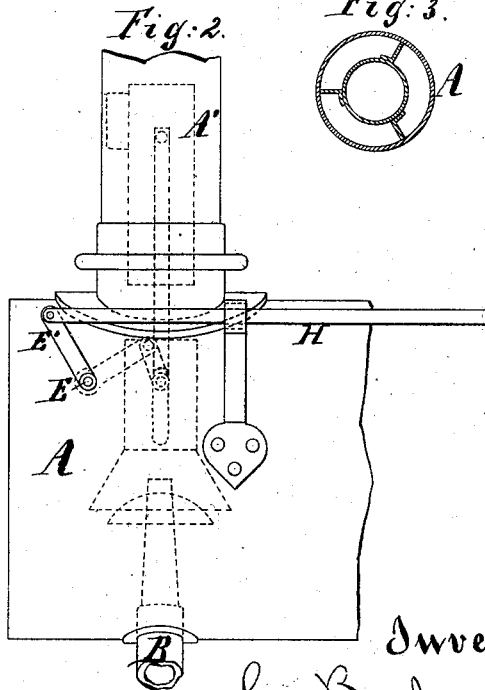
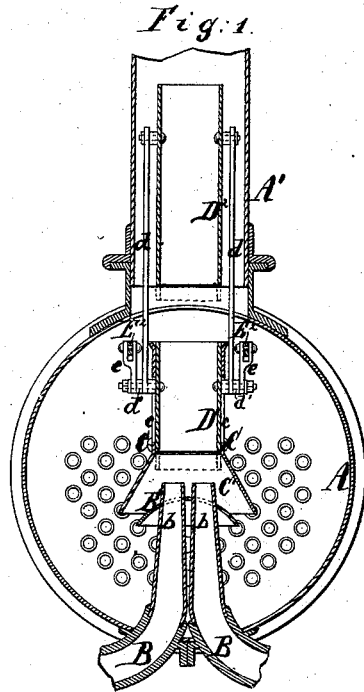

Witnesses:

Wm C. Day
Henry J. ...

Inventor:

Geo Bonker
his attorney
Thomas S. ...

UNITED STATES PATENT OFFICE.

GEORGE BONKER, OF PORT JERVIS, NEW YORK.

IMPROVEMENT IN EXHAUST MECHANISMS.

Specification forming part of Letters Patent No. **165,437**, dated July 13, 1875; application filed June 12, 1875.

To all whom it may concern:

Be it known that I, GEORGE BONKER, of Port Jervis, in Orange county, in the State of New York, have invented certain new and useful Improvements Relating to Draft-Regulators, of which the following is a specification:

The invention is designed more particularly for the smoke-boxes of locomotive-engines; but it may be useful when correspondingly placed in connection with other high-pressure engines and boilers.

I use the ordinary steam-jet as a means to quicken the draft. It is highly convenient to discharge the steam under all conditions through the same nozzles, mounting them in the position that is most effective in promoting the draft; but there are many conditions under which it is desirable to discharge the steam through the nozzles without thereby quickening the fire.

The object of my invention is to provide for varying the conditions within very wide limits.

There are practical objections to the opening and closing of exhaust-nozzles. It has been found in practice that a sufficient forcing of the draft could be obtained with such a capacious blast-orifice as will not induce a serious back pressure on the piston. A new condition is, however, developed in the use of judiciously-constructed locomotives, in that the draft is liable to be too much forced under some conditions.

There is much of the time in hauling light trains, or even in hauling heavy ones, over level portions of the track when the locomotive will make steam too freely in consequence of a too powerful urging of the fire by the strong blast of steam up the chimney.

In one condition of my apparatus the steam-jet is in the highest degree efficient in promoting the draft. In another condition the effect of the steam-jet in promoting the draft is so slight as to be almost inappreciable.

The apparatus may be adjusted in various intermediate conditions at will.

The accompanying drawings form a part of this specification, and represent what I consider the best means of carrying out this invention.

Figure 1 is a cross-section through the

smoke-box of the locomotive, and through the blast-pipes and other principal parts. Fig. 2 is a side elevation corresponding thereto, and Fig. 3 a cross-section.

The strong lines in Fig. 1 show the parts adjusted for the strongest draft. The dotted lines in the same figure show the parts partially lowered to reduce the draft.

Similar letters of reference indicate like parts in both the figures.

The drawings show the novel parts with so much of the ordinary parts as is necessary to indicate their relation thereto.

A is the barrel or cylindrical shell of the smoke-box; and A' the outside or main chimney attached to the smoke-box as usual, and adapted to perform its ordinary functions of conducting upward the hot gases and the exhaust steam. B B are exhaust-pipes, receiving steam in strong blasts from the cylinders and delivering it upward in or near the central line of the chimney from the nozzles *b b*. C is a petticoat-pipe, formed with a vertical slot, *c*, on each side, and held stationary by braces (not represented) over the blast-nozzles *b b*; and C' is a flaring bottom thereof, which extends below the ends of the blast-nozzles. B' is a convex shell mounted in the position represented, a little below the mouths of the blast-nozzles *b*.

There is ample space between the edges of B' and C' for a large portion of the products of combustion to move freely; and except for further parts, to be described, the discharge of the steam through the blast-nozzles *b* would always induce a very vigorous draft, a large portion of the products of combustion being drawn under the flaring mouth C' and urged up the interior of the pipe C.

D¹ D² are lengths of pipe, the first, D¹, fitting easily within the petticoat-pipe C, and the second, D², mounted a considerable distance above it, and being held in a concentric position within the chimney A' by means of wings, so that it is free to be moved up and down, maintaining its concentric position. The parts D¹ and D² are connected by side rods *d d*, connected to brackets, as shown. The lowermost brackets, *d'*, are fixed on the pipe D¹, moving freely in the slots *c* in the pipe C.

Links *e e* connect the brackets *d'* to arms E^2 , mounted on a rocking shaft, *E*. A rod, *H* is connected to another arm, E^1 , on the shaft *E*, and leads to the vicinity of the engineer, where provisions are made by notches or otherwise for holding it at will in any desired position.

The parts are so proportioned that when the arms E^2 are in their highest position the pipe D^1 is entirely within the petticoat-pipe *C*, and is of no effect. The pipe D^2 is also at a considerable height in the chimney, and as it is of little thickness, and the products of combustion are allowed to move freely inward and outward below it, it is of little effect. It exerts a slight influence in inclosing the violent currents of steam ejected from the nozzles *b*, and causing them to act efficiently on the products of combustion, which have free access thereto not only under the flaring petticoat-pipe *C*, but also again between the pipes D^1 and D^2 .

When the engineer wishes to reduce the draft he moves the rod *H* and turns the shaft *E*, so as to lower the pipes D^1 D^2 more or less. In proportion as he does this the draft is diminished without affecting the escape of the steam, or in any way materially modifying its flow up the interior of the chimney. When, in an extreme case, as, for example, on the last part of an ascent immediately before descending a grade, the locomotive is discharging steam from its nozzles *b* with full force, but it is desired not to thereby increase the draft in the furnace, the engineer draws the arm E^1 as far as possible, thereby lowering the pipes D^1 and D^2 to their extreme lowest position. Thus situated, the lower edge of the pipe D^1 matches down upon the convex shell *B'*, forming an almost gas-tight joint therewith, clear around. This prevents any of the gaseous products of combustion from entering the pipe D^1 . The same movement brings the lower edge of the pipe D^2 to match upon and a little within the upper end of the petticoat-pipe *C*. This forms an almost gas-tight joint there, thus preventing any of the products of combustion from entering the pipe D^2 . It follows that in this condition of the apparatus the exhaust steam is ejected from the nozzle *b* through the entire space inclosed within the pipes D^1 C D^2 up to the top of D^2 without exerting any influence on the products of combustion, which rise, stimulated only by their natural levity, through the annular space between the outside chimney *A'* and the said internal pipes, and only come in contact with the exhaust steam after their ascent above the upper edge of the pipe D^2 .

The pipe D^2 may be carried quite to the top of the chimney *A'*, if preferred in any case; but, for general practice, I prefer to leave it at about the height indicated in the drawings. The slight action of the ascending current of steam upon the hot products of combustion near the top of the chimney does

not force the draft to such an extent as to be serious.

Care should be taken, in the proportioning of the parts, to leave a sufficient space between the inner pipes C D^1 D^2 and the outer pipe or chimney proper *A'*, to allow a reasonably-free escape for the products of combustion. In ordinary working, however, the pipes D^1 D^2 will be partially or entirely raised. The engineer should raise them to their highest extent, so as to promote the draft in the highest degree, in ascending grades, or whenever a vigorous action of the fire is desired. Under circumstances where less forcing of the fire is desired, he will lower them until only the proper amount of force is applied to the draft. As they are raised and lowered, a space for receiving the products of combustion is increased and diminished, not only under the lower edge of the lower pipe D^1 , but also under the lower edge of the upper section D^2 .

I can divide the movable pipe D^1 D^2 into more than two sections, similarly mounted with regard to a correspondingly-increased number of stationary pipes *C*; but I believe two sections, and consequently two spaces, to receive the gases, will be generally sufficient.

Some part of my invention may be useful without the others; but I prefer to use the whole as here represented.

In order to isolate the steam current to the fullest possible degree when the movable pipes or sections D^1 D^2 are lowered, the brackets *d'*, and the slots *c* in which they play, should be placed so low that the slots will be entirely closed by the inner pipe D^1 when the apparatus is worked in the closed condition.

The shell *B'* may, if preferred, have a simple conical form, instead of the spherical form represented. I esteem it important that it shall taper, as it aids in deflecting the current of gases upward when the apparatus is nearly closed, and contributes to accurately center the pipes when they are in the lowest position.

My invention can be used in combination with a steam jet, variable blast-nozzles, or other devices for increasing the draft. So combined, the devices for quickening the draft may be used in preparing to mount an incline, and in actually mounting; and then such devices, being first thrown out of use for the time being, my pipes D^1 D^2 may be lowered to reduce the effect of the blast to any desired degree, thus giving very unusual control over the action of the fire.

I claim as my invention—

1. The tapering-formed shell *B'*, arranged as shown, relatively to the blast-nozzles *b* and movable pipe *D*, and receiving the lower edge of the latter on its swelled surface, and compelling it to rest concentrically thereon, for the purposes specified.

2. The movable sections D^1 D^2 , and means for elevating and depressing them, in combination with the petticoat-pipe *C*, blast-nozzles *b*, and a stop-disk or shell, all arranged to op-

erate relatively to each other and to the inclosing-chimney A, as and for the purposes herein specified.

3. The flaring mouth C' and the petticoat-pipe C, arranged, as shown, relatively to the lower section D' and to the nozzles *b* and stop-surface B', as specified.

In testimony whereof I have hereunto set my hand this 8th day of June, 1875, in the presence of two subscribing witnesses.

GEORGE BONKER.

Witnesses:

WM. C. DEY,

HENRY GENTNER.