

G. W. WHITE.
Ore-Concentrator.

No. 165,462.

Patented July 13, 1875.

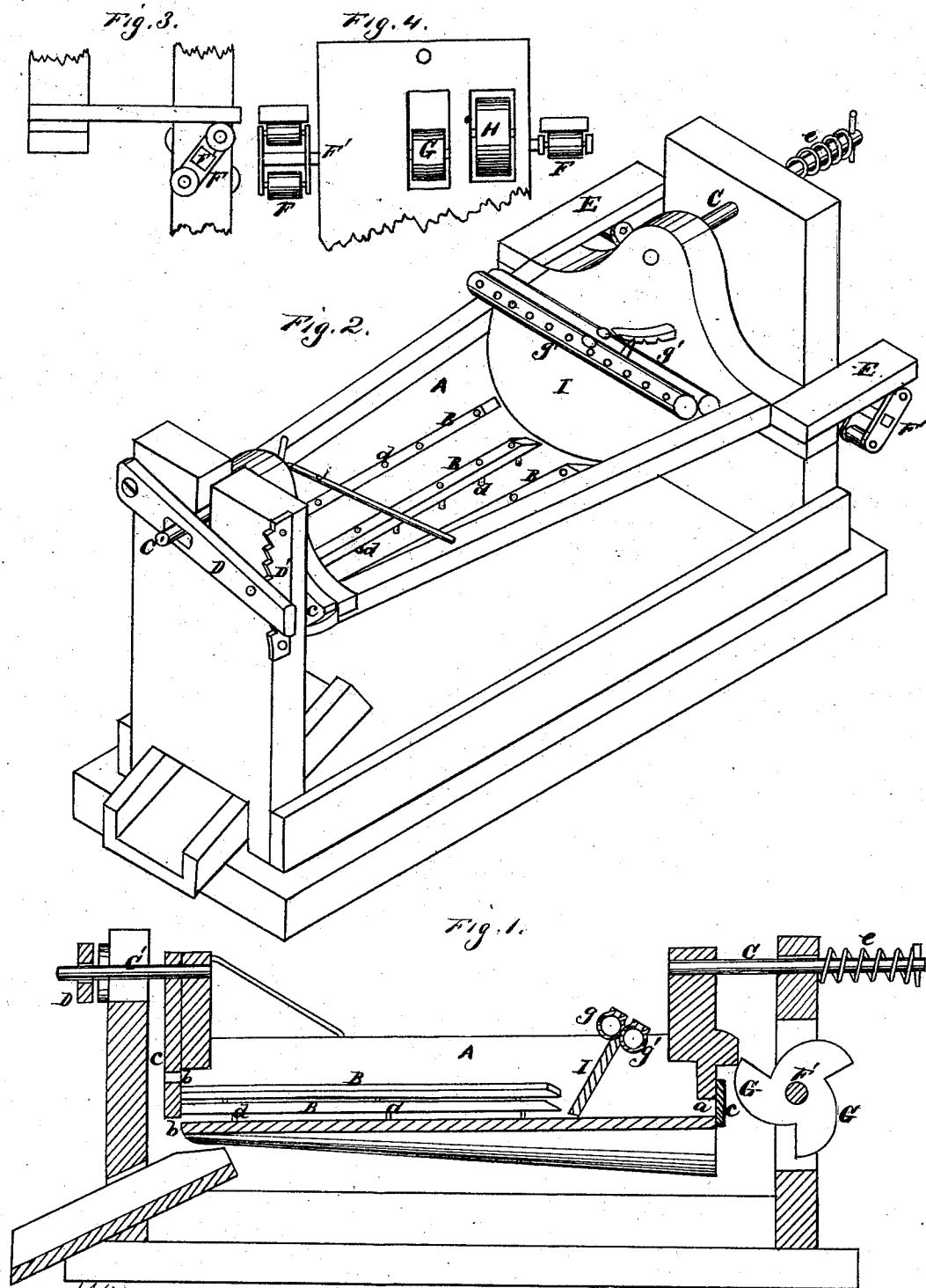

Witnesses.
C. G. Anthony
J. W. Brown

Inventor,
George W. White
By C. W. Smith, atty.

UNITED STATES PATENT OFFICE.

GEORGE W. WHITE, OF SAN FRANCISCO, CALIFORNIA, ASSIGNOR TO JAMES M. THOMPSON, OF SAME PLACE.

IMPROVEMENT IN ORE-CONCENTRATORS.

Specification forming part of Letters Patent No. **165,462**, dated July 13, 1875; application filed January 10, 1874.

To all whom it may concern:

Be it known that I, GEORGE W. WHITE, of San Francisco, in the county of San Francisco and State of California, have invented an Improvement in Concentrators for the Separation and Concentration of Metals contained in Ores; and I do hereby declare that the following is a full, clear, and exact description of the same, reference being had to the accompanying drawings and to the letters marked thereon.

My invention relates to that class of machines employed for concentrating or separating substances of different specific gravities, and more especially the metals or sulphurets contained in ores, or that portion which has escaped the process to which the ores are usually subjected before passing into a concentrator.

This invention consists mainly in providing a concentrator with special mechanism for giving it oscillating and concussive movements. It consists, also, in certain details of construction, which, in connection with the foregoing, will be fully described hereinafter.

In the machines heretofore employed, a simple motion, either oscillatory or concussive, has only been used, and in but few of them has there been any efficient means or device employed to discharge all the substances after their separation, on which the perfect as well as rapid operation of any concentrator mainly depends.

The receptacles into which the ore, pulp, or other substance is introduced, and the separation effected, can be of any desired form; but I prefer the cylindrical and slightly conical shape, on account, mainly, of its economy in construction as compared with the pans, cones, or tables which are usually employed, and many mechanical devices may be employed to impart the combined oscillatory and concussive motions to the concentrator; but after much experiment I have adopted the device I herein describe, as it is simple and effective, employing but one shaft and the odd number of cams combined with the double eccentrics, producing what I have found to be the best combination or relative amount of

the two motions—the oscillation in combination with the suspended riffles, hereinafter described—serving to agitate and counteract the packing effect of the concussion, while the concussion serves to carry the heavier particles backward, by which the separation is effected.

To more fully describe my invention, reference is had to the accompanying drawings, in which—

Figure 1 represents a longitudinal section of my machine. Fig. 2 is a perspective view; Fig. 3, a side view of one of the double eccentrics. Fig. 4 is an end view of the eccentrics and cams.

A represents the concentrator, made preferably half oval, or cradle shape, and contracted toward its front end, with sufficient spaces or openings, *a a'* and *b b'*, at each end, which are adjustable by means of the sliding gates *c c'*, and through which the contents of the concentrator are discharged after the separation is effected. In the bottom of the trough are placed parallel riffles or bars B B, which are suspended or raised by pins *d d*, so that communication from one compartment to the other is had. By this means the charge of ores is spread over a larger surface, affording a much thinner sheet for the water to act upon than if the whole were allowed to accumulate in the lowest depression of the trough and become hard by impact, in which case the streams or jets of water would act only upon the surface of the ore and not disturb or agitate the lighter particles, which in that case would be incorporated with the heavier.

The cradle is supported in the frame by rods C C', and the lower end is adjustable by means of a lever, D, having a pawl and ratchet, D', so that the end of the cradle can be raised and lowered at will to give the desired inclination; and in general I prefer the trough to incline downward toward the rear end, through which the heavier portions are discharged. From the opposite end of the cradle extend arms E E, upon which the double eccentrics F F impinge, which are attached to the ends of the transverse shaft F', which passes through a post at the end of the frame. These

eccentrics, being placed on the shaft at different angles, strike alternately upon the under side of the arms E E, and impart an oscillating motion to the cradle, which serves to keep the ore and debris agitated, and loosely suspended in the water, by which the heavier particles are left free to fall to the bottom by their gravity, where they are carried backward by the concussion, and the lighter and worthless portions remain in suspension and are carried forward by the current of water, which moves in that direction, and discharged through the openings *b b* at the front end of the concentrator, while the heavier and valuable particles pass through the openings under the riffles and partitions, and are discharged through the adjustable openings *a a* at its opposite end or rear, being accelerated by the action of the triple cam G, also upon the shaft F', which impinges against the end of the cradle when power is applied to the pulley H through the medium of a belt which turns the shaft F'. These cams, in combination with the spring *e*, impart a concussive or percussive force to the cradle, which tends to throw down and force the heavier particles of metal back to the end of the cradle from whence the blows are received, while the oscillating motion serves to raise or loosen by agitation the lighter particles, which float off at the opposite end by the action of the water.

It should here be observed that the riffles do not extend the whole length of the cradle, but sufficient space is left for the gate I.

The rods C C' can be secured to the ends of the concentrator or trough at any height desired above its bottom, so that any modification in the swinging or oscillatory motion of the concentrator can be made which may be required for the different varieties of pulps or ore to be concentrated, and the curve of the bottom of the trough or concentrator may be increased or lessened, as may be desired. Two perforated water-pipes, *g g'*, are also provided, which pass across the concentrator just over the gate or partition I. The water flowing from

the forward pipe *g* into the concentrating-apartment serves to assist in producing the current by which the lighter or worthless portions are carried forward and discharged, while the water flowing from the other pipe *g'* serves to prevent the escape of water through the discharge-openings *a a* at the rear end from creating a counter-current toward that end, which would interfere with the process of concentration; and the quantity of water can be regulated so as to exactly counteract the waste produced by the discharge through the discharge-openings *a a*, and keep the level of the water in front and rear of the partition the same; or the flow of water through the pipe *g'* can be increased, so as to cause a slight current under the gate toward the front end of the trough, as the concussion would cause the heavier particles to move backward and through the discharge-openings *a a*, notwithstanding the opposite movement of the water.

Having thus described my invention, what I claim as new, and desire to secure by Letters Patent, is—

1. The concentrator A, having the double eccentrics F F, triple cam G, and rod C, with spring *e*, by means of which it has imparted to it oscillating and concussive movements, substantially as described.

2. The concentrator A, provided with the suspended or raised longitudinal ledges or riffles B B, operating substantially as described, and for the purpose set forth.

3. The concentrator A, with its arms E E, adjustable suspending-rods C C', spring *e*, and adjustable lever D, with pawl and ratchet D', in combination with the shaft F', with its double eccentrics F F and triple cam G, substantially as described, and for the purpose set forth.

In witness whereof I have hereunto set my hand and seal.

GEO. W. WHITE. [L. S.]

Witnesses:

C. W. M. SMITH,
A. G. ANTHONY.