

E. P. RICHARDSON.  
Machine for Sewing Turned Shoes.

No. 165,506.

Patented July 13, 1875.

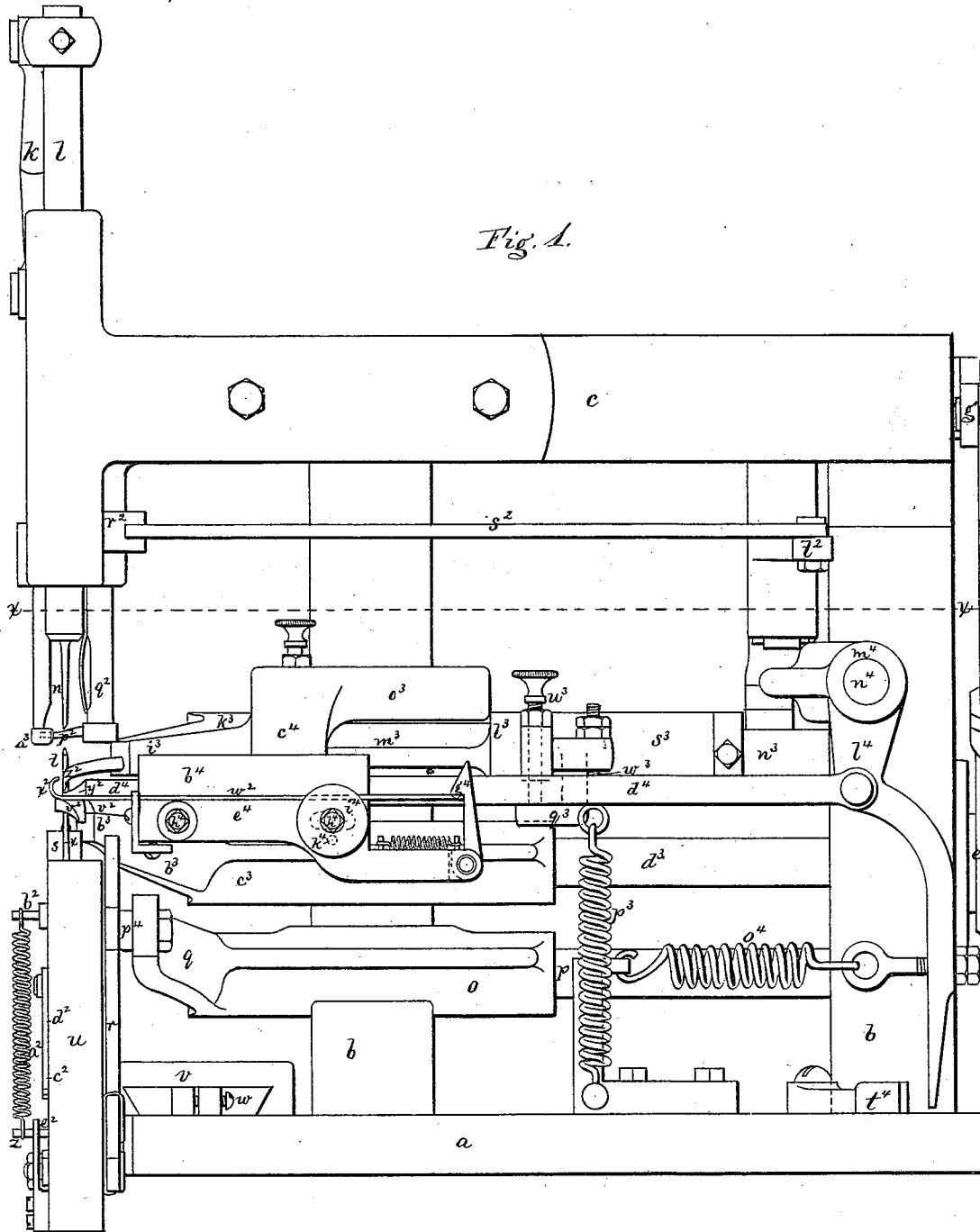

Fig. 1.

Witnesses  
M. W. Frothingham.  
G. H. Leatimer.

Inventor  
Everett P. Richardson.  
By his Atty.  
Crosby & Gould.

E. P. RICHARDSON.  
Machine for Sewing Turned Shoes.

No. 165,506.

Patented July 13, 1875.

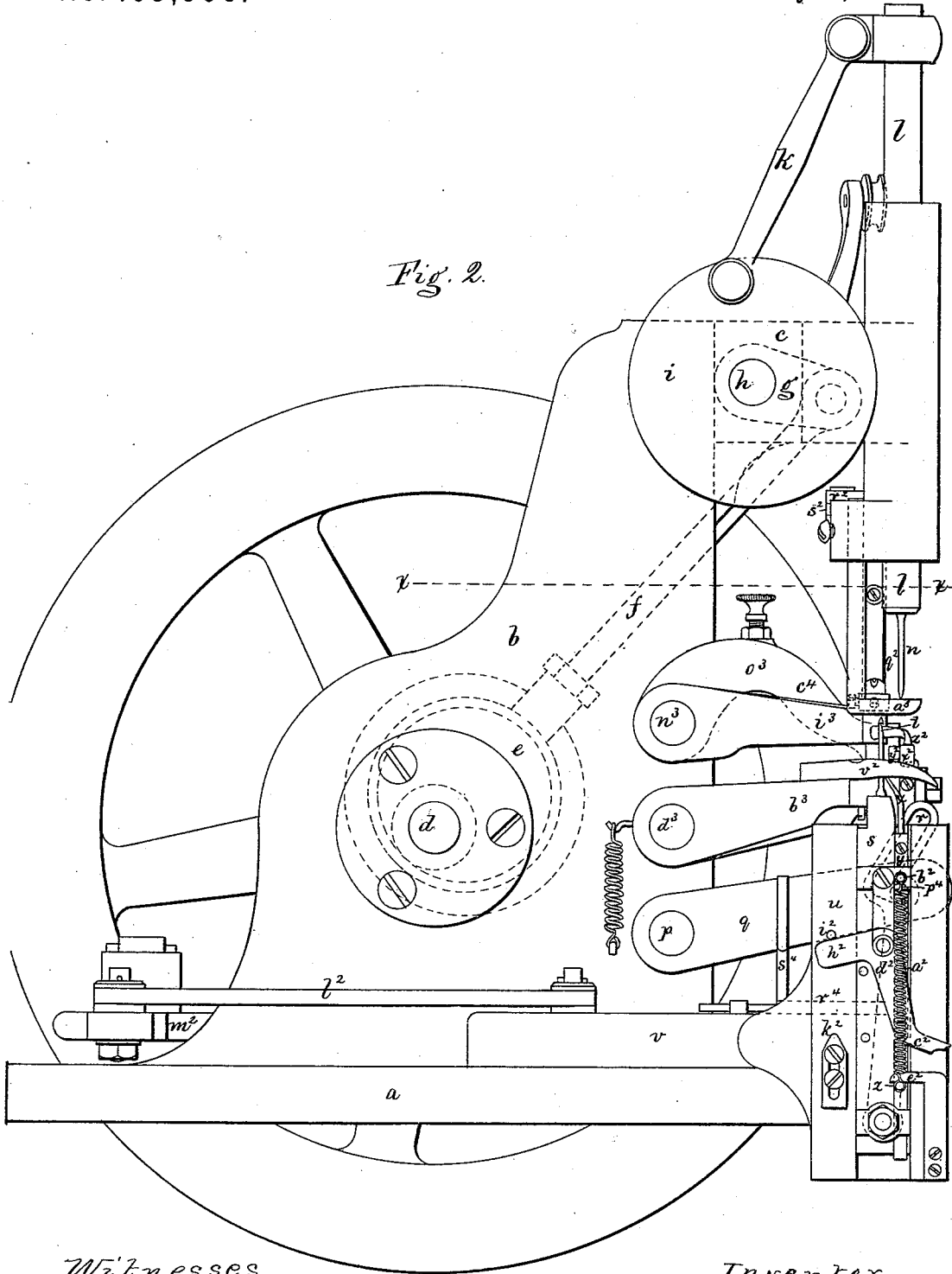

Fig. 2.

Witnesses.  
A. W. Frothingham.  
L. H. Catmer.

Inventor.  
Everett P. Richardson  
By his Attys.  
Crosby & Gould

**E. P. RICHARDSON.**  
**Machine for Sewing Turned Shoes.**

No. 165,506.

Patented July 13, 1875.

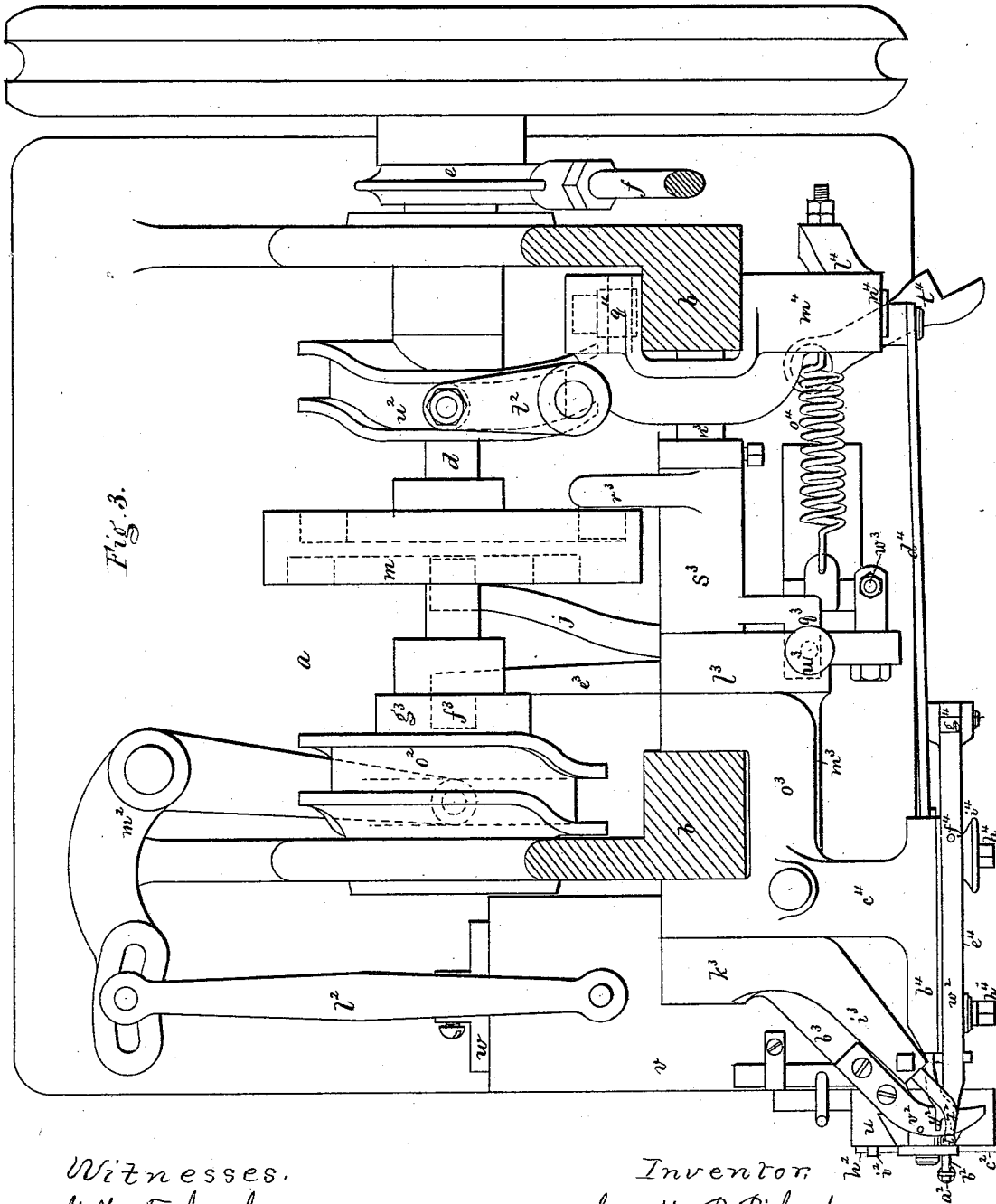

*Fig. 3.*

*Witnesses.*  
*M. W. Frothingham.*  
*L. H. Latimer.*

*Inventor*  
*Everett P. Richardson*  
*By his Atty.*  
*Crosby & Gould*

# UNITED STATES PATENT OFFICE.

EVERETT P. RICHARDSON, OF LAWRENCE, MASSACHUSETTS.

## IMPROVEMENT IN MACHINES FOR SEWING TURNED SHOES.

Specification forming part of Letters Patent No. **165,506**, dated July 13, 1875; application filed December 17, 1873.

*To all whom it may concern:*

Be it known that I, EVERETT P. RICHARDSON, of Lawrence, in the county of Essex and State of Massachusetts, have invented certain Improvements in Machines for Sewing Turned Shoes; and I do hereby declare that the following, taken in connection with the drawings which accompany and form part of this specification, is a description of my invention sufficient to enable those skilled in the art to practice it.

This invention relates to details of construction and organization of machines for sewing what are known as "turned shoes," in the manufacture of which each shoe is made without an inner sole, (fastened to the outer sole,) the edges of the vamp or upper and the outer sole being united by stitches, and the parts in the process of effecting the union being wrong-side out, the shoe being turned when the union of the sole and upper is completed.

Of the drawings representing the invention, Figure 1 shows the machine in front view. Fig. 2 is a side elevation of it. Fig. 3 is a sectional plan on the line *x x*.

The machine is designed to stand upon a suitable supporting-pedestal to bring the sewing mechanism to the proper height for the manipulations of the operator who stands before it, the shoe being supported and held and fed by the mechanism, guided, to a greater or less extent, by the operator.

*a* in the drawing denotes a base-plate, which stands upon the pedestal. From this plate extend two vertical housing-stands, *b b*, at the top of which is a horizontal head-piece, *c*. *d* denotes the main driving-shaft, and upon this shaft is an eccentric, *e*, connected, by an eccentric strap and a link, *f*, to an arm, *g*, on one end of a rocker-shaft, *h*, at whose opposite end is a crank-wheel, *i*, connected, by a link, *k*, with the awl-bar *l*, carrying at its foot the awl *n*, that punctures the work for and preparatory to the entrance of the needle, the awl-bar reciprocating vertically in a suitable bearing formed in an extension of the head *c*. The driving-shaft also carries a cam-wheel, *m*, in which is a cam-groove having extending into it a pin projecting from an arm, *j*, of a rocker-sleeve, *o*, mounted on a stationary shaft or bolt, *p*, connecting and extending through

the housing-plates *b b*, one part of this sleeve being at the inner side of the front housing-plate, and the other part at the outer side thereof, (thereby embracing the stand and keeping the sleeve in position,) and an arm, *q*, extending from the sleeve being connected, by a link, *r*, to the needle-bar *s*, from the top of which extends the needle *t*. The needle-bar reciprocates vertically in a vertical plate, *u*, which plate is an arm extending from a horizontal slide-plate, *v*, which reciprocates laterally upon a guide-piece, *w*, on top of the base-plate *a*, to effect the lateral or feed movement of the needle. The needle is a hook-needle, and, in connection with it, works a cast-off, *x*, that closes the eye or hook of the needle at proper times. This cast-off is fixed in the top of a bar, *y*, that slides vertically on the needle-bar *s*. The conjoint operations of the awl, needle, and cast-off, to form the successive stitches, are the same as in ordinary wax-thread sewing-machines, the part of the invention immediately relating to them being confined to the construction or arrangement of the mechanism that actuates them, one of the novel features consisting in the construction of the rocker-sleeve *o* with two parts, that embrace the front housing-stand *b*, and thereby keep the arms *j q* in correct position, and another feature consisting in the method of actuating the cast-off. From the front of the cast-off bar extends a pin, *z*, to which one end of a spring, *a<sup>2</sup>*, is fastened, the opposite end of said spring being fastened to a pin, *b<sup>2</sup>*, projecting from the needle-bar. As the needle-bar commences to rise the stress of the spring causes the cast-off bar to rise with it, the cast-off being kept in proper position, with reference to the needle, by an arm, *c<sup>2</sup>*, extending from a lever, *d<sup>2</sup>*. In such position the cast-off is just below the needle-hook. The cast-off there remains until the pin *z* strikes a stop, *e<sup>2</sup>*, and the needle point and hook then pass up through the work, the point of the cast-off being just above the top of the work-support. The needle having completed its rise, and the thread having been thrown into its hook, the needle descends and the cast-off remains stationary with relation to it until the hook reaches and passes the point of the cast-off, when they descend together, the arm *c<sup>2</sup>* strik-

ing against the pin  $z$ . As the needle-bar rises the lever is swung laterally on its fulcrum by reason of its arm  $h^2$  striking a pin,  $v^2$ , thus permitting the needle-bar to descend at the side of the cast-off bar until the hook reaches the point of the cast-off, (which it could not do were the lever-arm  $c^2$  over the pin  $z$ .) and just before the needle-bar reaches its lowest position, the arm  $h^2$  strikes an adjustable stop,  $k^2$ , thereby throwing the arm  $c^2$  again over the pin  $z$ , so that the needle-bar and cast-off bar will rise together. The slide-plate  $v$  is moved to effect the lateral movement of the needle and consequent feed of the work by means of a link,  $l^2$ , a lever,  $m^2$ , and a cam,  $o^2$ , the cam  $o^2$  being on the driving-shaft, and having a pin extending from one arm of the lever into its peripheral cam-groove, the other arm of the lever being jointed to one end of the link, whose other end is jointed to the slide-plate.  $p^2$  denotes the thread guide that carries the thread against the needle, and into position to be caught by the descending hook. This guide extends from the foot of a vertical shaft,  $q^2$ , turning in stationary bearings, said shaft having an arm,  $r^2$ , to which a link,  $s^2$ , is jointed, said link connecting the arm to one arm of a rocker-lever,  $t^2$ , from whose other arm a pin or roll extends into a peripheral cam-groove of a cam-wheel,  $w^2$ , on the driving-shaft, the cam effecting the forward throw of the thread-guide at each rise of the needle, and its back throw when the needle descends.

The stitch-forming and feeding mechanism having been thus described, the arrangement of the special devices for presenting, holding, supporting, and guiding the parts to be united will now be set forth.

The outer sole of the shoe to be sewed has a piece cut from its inner face at the edge, and an inclined slit, gash, or channel is cut from said face toward such edge, and the upper and sole are temporarily united upon a suitable last. The upper, at the needle-entering point, is to rest upon an arm or throat-piece,  $v^2$ , and between the edge of the outer sole and the upper is to extend the shank  $w^2$  of a hook,  $x^2$ , the point of the hook being bent so as to come against the sole opposite to the bottom of the gash before spoken of. The edge part of the sole beyond this gash is bent into the hollow of the hook by the point of a bender,  $y^2$ , preparatory to each descent of the awl and rise of the needle, and the channel formed by the gash is always kept open at the needle-entering point by a channel-foot,  $z^2$ . The parts being all thus positioned, and the shoe held against a suitable guide,  $a^3$ , and the devices being clamped to hold the parts of the work firmly in position, the awl descends, punctures a hole through the sole and upper, and the needle ascends through the awl-puncture, following the ascending awl. The needle then descends, and in its descent carries the thread or loop to form the stitch, the gripe upon the united parts is then released, and the shoe then fed, and the parts are then again griped

for the next movement of the awl and needle to form the new hole and carry a new loop of thread through the loop last formed, this succession and union of the stitches forming the seam that unites the sole and upper.

In this way the shoe to be sewed is held and presented to the needle as in patent No. 94,134.

The arrangement of the mechanism for actuating the devices thus described is as follows:

The throat-piece (which has the throat or slot through which the needle and awl work) is at the end of an arm,  $b^3$ , extending from a two-part rocker-sleeve,  $c^3$ , like the sleeve  $o$ , the sleeve  $c^3$  being cut out so as to embrace the front housing-stand  $b$ , and turning on a shaft or bolt,  $d^3$ , connecting the two housing-stands. An arm,  $e^3$ , extending from this sleeve, has a roll,  $f^3$ , against which runs the periphery of a wheel,  $g^3$ , on the driving-shaft, and the contact of this periphery and the roll holds the throat-plate at all times firmly up to the hook-shank  $w^2$ , to gripe the upper between the shank and the throat-plate and support the shank, except at the time the work is to be fed, the roll then coming opposite to a recess in the periphery of the wheel  $g^3$ , which recess permits the sleeve to turn and the throat-plate to fall. The shank of the channel-foot or opener  $z^2$  extends from an arm,  $i^3$ , which projects from a rocker-sleeve that also has two parts,  $k^3 l^3$ , united by a strut,  $m^3$ , these two parts (as one) being mounted and turning upon a stationary bolt or shaft,  $n^3$ , that connects the housing-stands  $b b$ , the two parts  $k^3 l^3$  extending by the opposite sides of the housing-stand, but immediately embracing, not the stand, but another two-part sleeve,  $o^3$ , which embraces the stand. The arm  $l^3$  of the channel-foot sleeve is connected, by a spring,  $p^3$ , to the base  $a$ , to hold the foot down normally, and the arm is raised (against the stress of the spring) to lift the foot as follows: Beneath the arm  $l^3$  is an arm,  $q^3$ , extending from a rocker-sleeve,  $s^3$ , mounted on the pin  $n^3$ , and having another arm,  $r^3$ , from which a pin,  $t^3$ , extends into a cam-groove in the rear face of the cam-wheel  $m$ , the action of this cam effecting the rise of the channel-foot as the needle reaches its highest position, and the foot being positively held up by the cam until after the work has been fed, it being then drawn down by the stress of the spring. By means of a set-screw,  $w^3$ , the extent of rise of the channel-foot may be varied, and by a screw,  $v^3$ , to which one end of the spring  $p^3$  is fastened, the pressure of the channel-foot may be regulated. The spring enables the foot to gripe in accordance with the varying thickness of sole between the bottom of the channel and the top of the channel-foot, the stress of the spring being sufficient to draw the foot down to tightly compress the leather, and the cam holding the foot away from the work when the work is to be fed.

The shank or bar  $w^2$ , at the end of which is the hook  $x^2$ , and the shank or bar whose

front end constitutes the bender-point, are both mounted in a frame-piece or plate,  $b^4$ , at the end of an arm,  $c^4$ , that extends from the rocker-sleeve  $o^3$ , which turns on the shaft or bolt  $n^3$ , and is cut away so as to extend over and embrace the opposite sides of the housing-stand  $b$ . The hook-shank and the bender-bar pass between the throat-plate  $v^2$  and the channel-foot, and the arm  $o^3$  is raised with and by the arm  $m^3$ , or the rocker-sleeve from which it extends, the bender and hook having, however, a capability of free up-and-down movement to some extent, independent of the channel-foot, but being raised with the foot. The bender-bar  $d^4$  sets back of the hook-shank, and slides forward and back on the frame  $b^4$ , but at its end it is bent forward, and one of the bender-points rests and slides upon the shank of the hook. The hook-shank rests upon a shoulder,  $e^4$ , and the hook is set in position by a gage-pin,  $f^4$ , that extends through a hole in the hook-shank. The shank is held by a spring-latch,  $g^4$ , by drawing back which the hook may be instantly removed to place the shoe in position, or to remove it. The shoulder-piece  $e^4$  is made movable for adjusting the position of the set-pin  $f^4$ , and thereby the position of the hook, it being fastened by bolts  $h^4$   $h^4$ , on one of which is a wheel,  $i^4$ , carrying a pin,  $k^4$ , extending into the shoulder-piece. By loosening the bolts and turning the wheel the pin will move the hook forward or back. The hook is set in accordance with the distance from the finished surface of the sole, at which the stitches are to enter, or the position of the foot of the channel, and once set, it is only altered when soles of different thicknesses are to be sewed. But the set-pin always brings the hook to correct position for successive soles of the same kind, and the shoulder-piece has rarely to be moved, except in setting up the machine, or in changing the class of work.

Prior to the feed of the shoe, the bender is always drawn back, and when the shoe has been fed the bender is thrown forward, preparatory to the descent of the needle, its forward movement bending the edge-part of the sole into the hollow of the hook, bringing the parts into position for the descent and puncturing movement of the awl, and the rise of the needle through the puncture as the awl recedes, or for the passage of the thread in the formation of the stitch.

The bender is moved as follows: The rear end of the bender-bar  $d^4$  is jointed to an arm,  $l^4$ , extending from a rocker-sleeve,  $m^4$ , which sleeve is made with a fork or opening, the two ends of which are mounted on the opposite ends of a bolt or stud-piece,  $n^4$ , the two parts of the sleeve embracing part of the rear housing-stand, and being thereby held in position. The bender-bar is thrown forward by the stress of a strong spring,  $o^4$ , and is held

in forward position by such spring, except during the feed of the work, when it is forced back by a cam-piece on the cam-wheel  $u^2$ , this cam-piece striking an arm,  $q^4$ , extending from the rocker-sleeve.

It will thus be seen that the hook  $x^2$  is immovable, (forward or backward,) and the forward movement of the bender being produced by the spring, the hook forms a gage, for the path of the needle, in relation to the finished surface of the sole, the bender pressing with sufficient force always to bend the sole to the hollow face of the hook, but its extent of forward movement being limited by the thickness of the part of the sole bent by it.

By means of a latch,  $t^4$ , the bender-bar  $d^4$  may be fastened back, for entrance of the work. When the work is to be introduced into the machine, the awl is thrown up to its highest position, and must be thrown up without being followed by the needle. To prevent rise of the needle, when necessary, the link  $r$  is made as a hook, its hooked end hooking upon the connecting-pin  $p^4$ , extending from the arm  $q$ . On top of the slide-plate  $v$  is a slide,  $r^4$ , which is moved forward by a wire,  $s^4$ . The end of this slide extends to or nearly to the link  $r$ , and when the needle-bar is to be thrown out of connection, the wire  $s^4$  is pressed forward and throws the link-hook from the pin. While so held, the needle will not rise, but upon releasing the slide the spring throws it back, and as the arm  $q$  descends its pin will strike the incline, and slide down upon and press back the link until it slips into the link-hook.

I claim—

1. The combination of the rocker-sleeve  $o$  and housing  $b$  with the link  $r$ , for imparting reciprocating movements to the needle-bar, substantially as shown and described.

2. The combination of the needle and cast-off bars with lever  $d^2$ , arm  $e^2$ , spring  $a^2$ , and stops for imparting the movements to the cast-off, relatively to the movements of the needle, substantially as shown and described.

3. The combination, with the needle-bar and slotted link  $r$ , of mechanism for throwing the needle-bar out of connection with its actuating mechanism, substantially as shown and described.

4. The combination of the rocker-sleeve  $m^4$  and its arms, the bender-bar  $d^4$ , and spring  $o^4$  for moving the bender forward, substantially as described.

5. The combination, with the adjustable shoulder-piece, of the hook  $x^2$ , and latch  $g^4$ , for adjusting the position of the hook and holding it, substantially as set forth.

EVERETT P. RICHARDSON.

Witnesses:

FRANCIS GOULD,  
M. W. FROTHINGHAM.

3150