

T. D. CASHIN.  
Needle-Sharpener

No. 165,540.

Patented July 13, 1875.

FIG. 1.

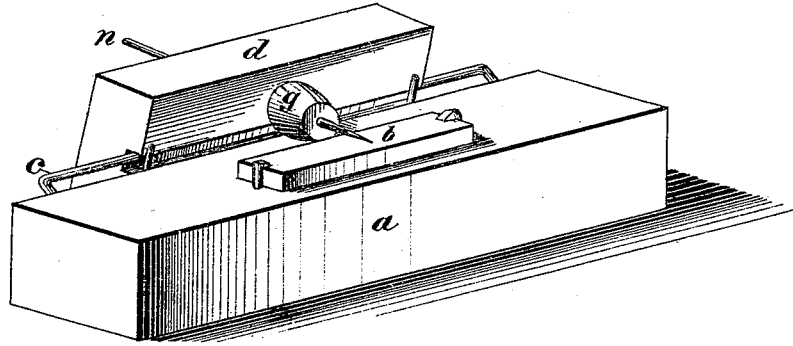

FIG. 2.

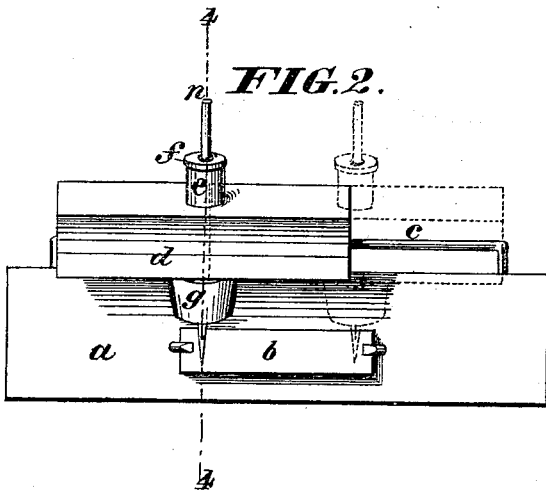

FIG. 3.

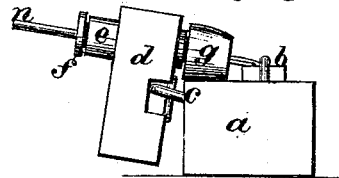
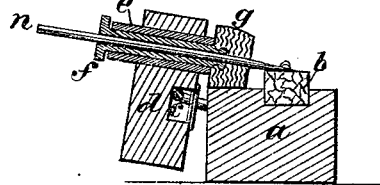

FIG. 4.



WITNESSES

*Geo. L. Coon*  
*Henry Tanner.*

INVENTOR

*Thomas D. Cashin.*  
By *Knight and* Attorneys

# UNITED STATES PATENT OFFICE.

THOMAS D. CASHIN, OF MONTROSE, PENNSYLVANIA.

## IMPROVEMENT IN NEEDLE-SHARPENERS.

Specification forming part of Letters Patent No. 165,540, dated July 13, 1875; application filed November 21, 1874.

*To all whom it may concern:*

Be it known that I, THOMAS D. CASHIN, of Montrose, in the county of Susquehanna and State of Pennsylvania, have invented an Improved Needle-Sharpener, of which the following is a specification:

This invention relates to means for sharpening sewing-machine needles; and consists, primarily, in a simple device, whereby the needle being sharpened is readily held at proper angles relatively to a block or strip of sharpening material, and is rotated automatically while it is reciprocated in contact with the sharpening-surface. The invention consists, further, in certain individual features of the device, as hereinafter set forth, and pointed out in the claims. The device is adapted to rest on any flat surface or to be held in the hand, and is operated by reciprocating a sliding piece. The needle is carried by the latter, and is held with elasticity and slowly rotated during its reciprocation by means of one and the same disk or wheel of rubber or analogous material.

In the accompanying drawing, Figure 1 is a perspective view of a needle-sharpener illustrating this invention. Fig. 2 is a plan view of the same, illustrating movement of the slide. Fig. 3 is an end view thereof. Fig. 4 is a transverse section on the line 4 4, Fig. 2.

This simple apparatus, which is designed for convenient use by any sewing-machine operator for sharpening ordinary straight needles, is constructed and operated as follows:

A base-piece, *a*, which may be about three inches long and rectangular in shape, as illustrated, supports a small longitudinal sharpening-stone, *b*, or a strip of sharpening material, on its upper surface. A small block of the finest Arkansas stone is preferred. This gives an almost polished surface, while it cuts very fast. At the front or right-hand edge or side of the base a longitudinal guide-bar, *c*, is provided, and to this a slide, *d*, is attached. The latter is made of convenient size to be grasped by the fingers, and has a transverse orifice, bushed by a sleeve, *e*, of suitable metal, within which a tube, *f*, is adapted to rotate. The outer edge of this tube is flanged to support it against displacement, and to the inner end of the same an elastic wheel or disk, *g*, is at-

tached. The attachment may be accomplished in the manner illustrated in section at Fig. 4, or in any other approved manner, the wheel or disk being adapted to grasp and hold the needle *n* near its point, and to equalize or render elastic the pressure applied thereto during the sharpening operation. The internal diameter of the tube *f* is sufficient to accommodate needles of the largest size and permit some lateral play. The elastic wheel *g* has a slightly beveled and convex periphery, which, in connection with provision for vertical and pivotal play at the guide-bar *c*, enables the operator to readily hold the needle at the proper inclination relatively to the sharpening-surface. In a cheap and practical form of the device, in which the base *a* and slide *d* are wooden, the latter is adapted to follow the guide-bar *c* by a longitudinal groove of proper dimensions, in connection with metallic staples crossing the said groove at its ends. The guide-bar *c* is of wire, in the form of a long staple driven into the base, and the stone *b* is secured within a recess by hook-headed tacks at its ends, as clearly represented in the drawing.

These details are not, however, essential, and the sharpening material *b*, guide-bar *c*, and the slide *d*, with its accessories, may be applied at a convenient point to the top of a sewing-machine table, instead of to an independent base, *a*. In another modification the needle may be rotated by rack and pinion, or by a ratchet device, simultaneously with its reciprocation.

The operation of my invention is as follows: To sharpen a needle, *n*, by this device it is inserted through the sleeve *f* and elastic wheel *g*, until its point projects a sufficient distance through the latter. The stone is oiled, if necessary, and the point of the needle is brought into contact with the stone at a proper angle, the elastic wheel *g* being at the same time pressed against the surface of the base *a*. The slide *d* is now reciprocated, and the point of the needle is thus carried over the sharpening-surface, and at the same time slowly rotated. The reciprocating movement distributes the wear on the stone, and greatly quickens the operation, while the rotation equalizes the wear of the point and preserves its shape. During the operation the needle

may be turned up from time to time for inspection. When the operation is finished the needle is withdrawn backward through the elastic wheel and tube.

The following is claimed as new in this invention, namely:

1. The elastic wheel *g*, journaled by means of an axial tube, *f*, and attached thereto at its inner or front end, and so as to project beyond the same, for grasping the needle near the point to hold it, and for graduating the pressure of the needle while it rotates the same in contact with a sharpening-surface, as herein illustrated and set forth.

2. The combination of the base *a*, support-

ing a block or strip of sharpening material, and provided with a pivotal guide-bar, *c*, and the slide *d*, having a transverse orifice, for reciprocating the needle in contact with the sharpening-surface at a proper angle, substantially as herein shown and described.

3. The combination of the slide *d*, rotary tube *f*, and elastic wheel *g*, for reciprocating a needle in contact with a sharpening-surface and simultaneously rotating the same, in the manner herein set forth.

T. D. CASHIN.

Witnesses:

JOHN SMITH,  
JOHN DAME.