

G. M. GERRISH.
Hydraulic Hoisting Engine.

No. 165,558.

Patented July 13, 1875.

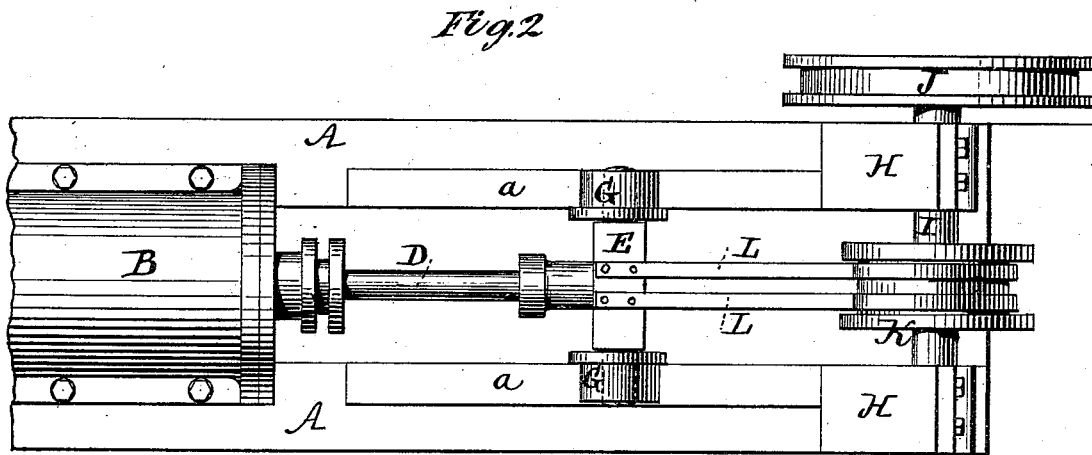
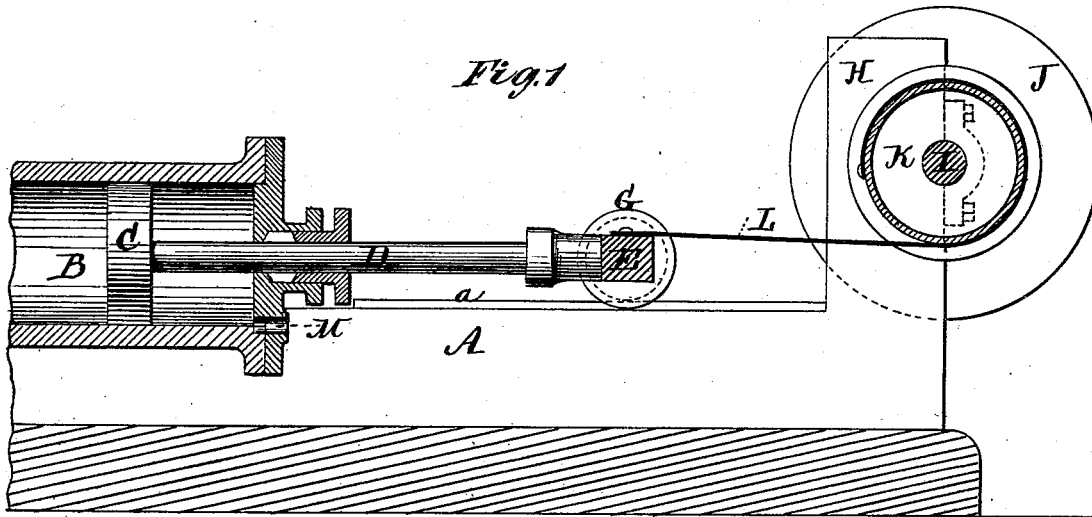

Witnesses:
Michael Ryan
Fred. Hayes

G. M. Gerrish
by his Attorneys
Brown & Allen

UNITED STATES PATENT OFFICE.

GEORGE M. GERRISH, OF BROOKLYN, NEW YORK.

IMPROVEMENT IN HYDRAULIC HOISTING-ENGINES.

Specification forming part of Letters Patent No. 165,558, dated July 13, 1875; application filed May 31, 1875.

To all whom it may concern :

Be it known that I, GEORGE M. GERRISH, of Brooklyn, in the county of Kings and State of New York, have invented an Improved Hydraulic Hoisting-Engine; and I do hereby declare that the following is a full, clear, and exact description of the same, reference being had to the accompanying drawing making part of this specification.

My invention relates to that class of hoisting-engines in which a single-acting piston is actuated by a column of water.

The invention consists in a novel construction, arrangement, and combination of the piston-rod, a cross-head and trucks, a hoisting shaft and drum, and their connections, whereby simplicity, economy, and efficiency are secured.

In the accompany drawing, Figure 1 is a longitudinal vertical section of my improved engine. Fig. 2 is a top view of the same.

A represents a bed or framework of any suitable construction, upon which is supported a cylinder, B, which is open at one end. In the cylinder B works a single-acting piston, C, attached to the inner end of a piston-rod, D, to the outer end of which is attached a cross-head, E. The ends of the cross-head carry two trucks, G G, which travel upon ways or guides *a a* on the upper part of the framework A. H H represent two standards, in which is journaled the hoisting shaft I. This shaft carries at one end a wheel, J, for connection with the elevator, and between the standards a drum, K. This drum and the outer end of the piston-rod are connected with each other by one or more flexible flat metal bands, L, one end of each band being secured to the drum and the other end to the cross-head or the end of the piston-rod. The engine thus constructed is connected with the elevator by means of the wheel J and a suitable system of belts or gears, so arranged as to give an increased motion to the elevator for a given motion of the engine.

When the elevator is at its lowest point, the bands L are wound around the drum K, and the piston is in position for the commencement of a stroke. When the elevator is to be raised, water is admitted to the cylinder by the port M, which port is connected with the column of water in any suitable manner. The water entering the cylinder acts upon the piston C, forcing it to the end of its stroke, or as far along as may be required, so as to unwind the bands L from the drum K and rotate the shaft I, and thus give motion to the elevator. When the elevator is to be lowered, the water is allowed to escape from the cylinder through a port provided for the purpose, whereupon the elevator will descend by its own weight.

The drum K and the cross-head E carrying the trucks G are so arranged with relation to each other that the draft of the bands L, in winding or unwinding, is slightly downward, by which means the trucks are kept in place upon the ways and the piston-rod is properly guided, without the necessity for an upper guide. By making the bands L of thin, flat, flexible metal, they are enabled to wind, each upon itself, in a straight line of draft, without occupying much space, instead of being wound spirally upon the drum and deviating from the line of draft, as would be the case if ropes were used.

What I claim as new, and desire to secure by Letters Patent, is—

1. The combination, with the piston-rod and hoisting-drum, of one or more flat metal band connections, L, substantially as herein shown and described.

2. The combination of the piston-rod D, cross-head E, trucks G G, hoisting-drum and shaft and connections, arranged as shown and described, for the purpose specified.

GEORGE M. GERRISH.

Witnesses :

BENJAMIN W. HOFFMAN,
FRED. HAYNES.