

J. W. KATES.

Non-Interfering Fire-Alarm Telegraph.

No. 165,591.

Patented July 13, 1875.

Fig. 1.

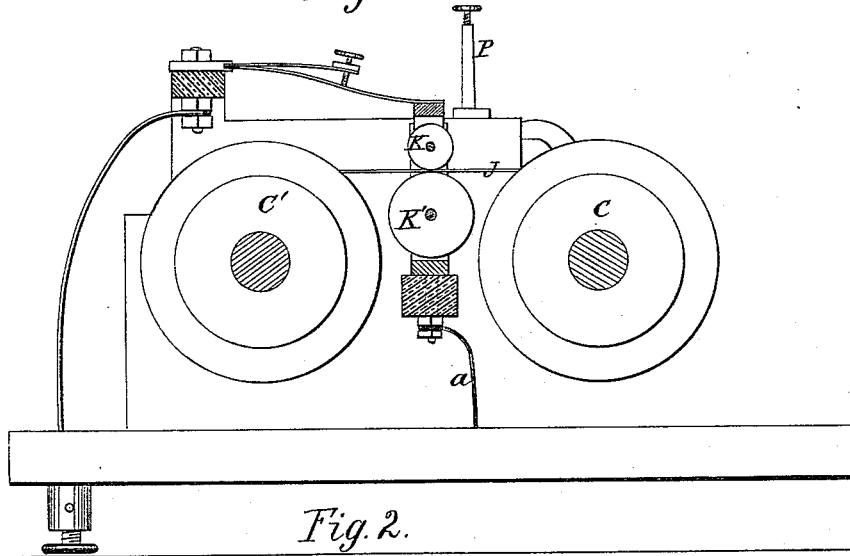
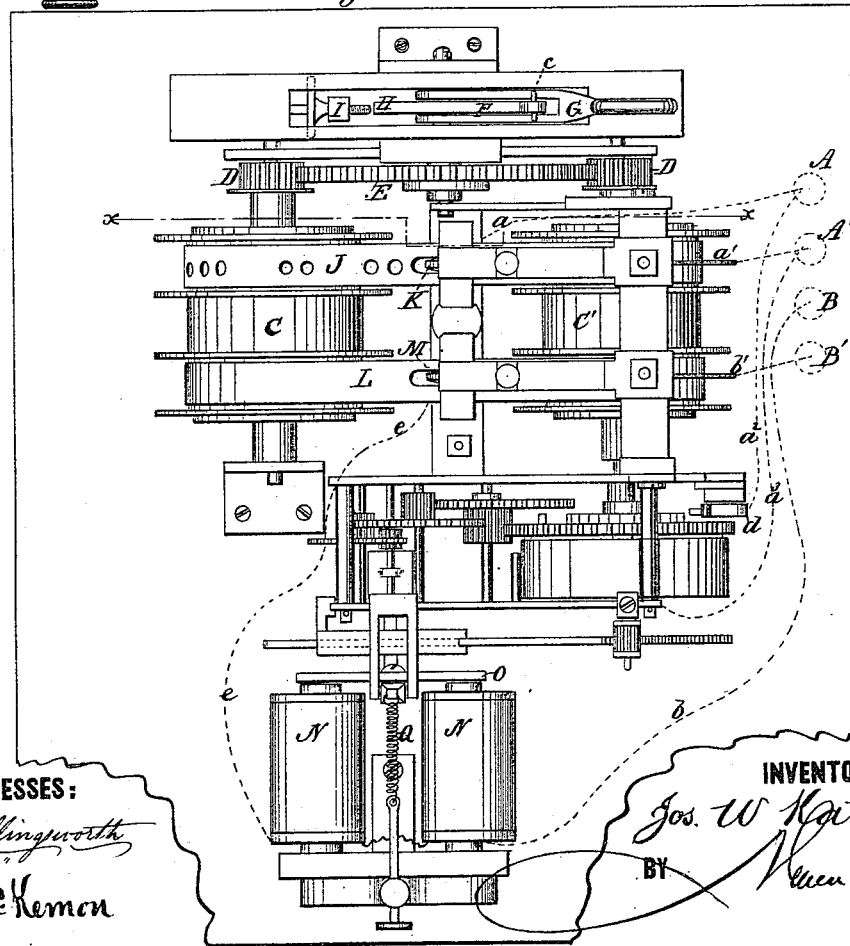

Fig. 2.



WITNESSES:

W. W. Hollingsworth
John C. Kemm

INVENTOR:

Jos. W. Kates
 BY *Wm. V. S.*

ATTORNEYS.

J. W. KATES.

Non-Interfering Fire-Alarm Telegraph.

No. 165,591.

Patented July 13, 1875.

Fig. 3.

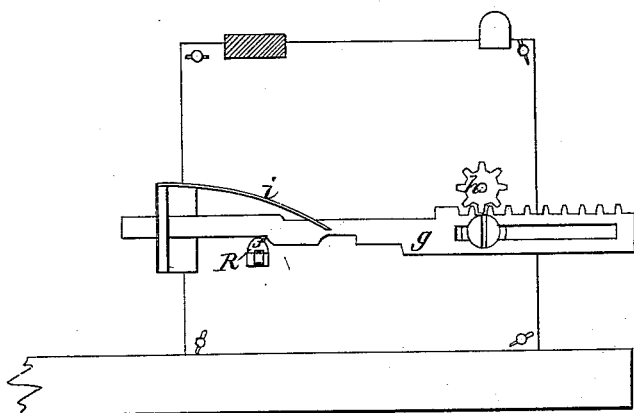
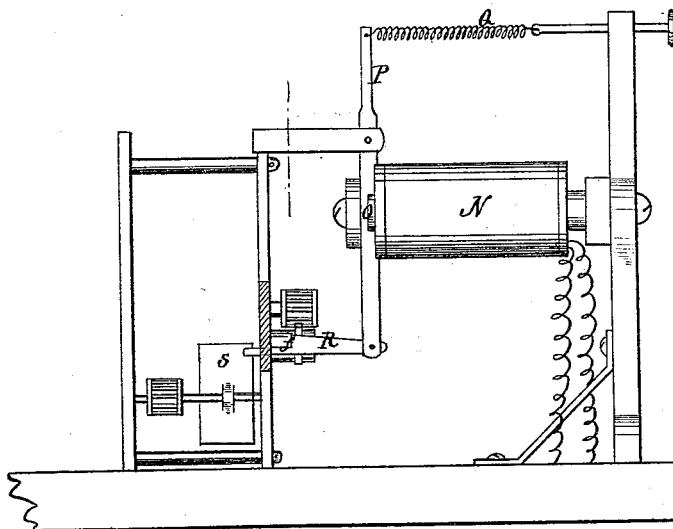

Fig. 4.



WITNESSES:

W. W. Hollingsworth
John Kemou

INVENTOR:

Jos. W. Kates
BY *Rich. V. B.*

ATTORNEYS.

UNITED STATES PATENT OFFICE.

JOSEPH W. KATES, OF RICHMOND, VIRGINIA.

IMPROVEMENT IN NON-INTERFERING FIRE-ALARM TELEGRAPHS.

Specification forming part of Letters Patent No. 165,591, dated July 13, 1875; application filed April 28, 1875.

To all whom it may concern:

Be it known that I, JOSEPH W. KATES, of Richmond, in the county of Henrico and State of Virginia, have invented a new and Improved Non Interfering Fire-Alarm Telegraph; and I do hereby declare that the following is a full, clear, and exact description of the same, reference being had to the accompanying drawing, forming a part of this specification, in which—

Figure 1 is a vertical section through line x of Fig. 2; Fig. 2, a plan view; Figs. 3 and 4 details of the non-interference devices.

The object of this invention is to provide an improved electric fire-alarm, in which is avoided the interference and confusion of signals, caused by the sending of two separate signals from different points at the same time.

It consists in a method of connecting the instruments at the different signal-stations by a second electric circuit, which circuit is opened or closed automatically to operate the armature of an electro-magnet, which serves as a stop for a clock mechanism, and locks, by means of the said second circuit, all of the instruments at the signal-stations, except the one in operation, for the prevention of all interference between the different instruments. It also consists in the method of automatically operating the armature, having a stop for the clock-gearing for the locking or unlocking of the other instruments, by a non-conducting tape placed upon the same drums with the signal-tape, and passing between central rollers that form the electrodes of the second circuit, and perforated at its extremities so that the second circuit is closed for this particular instrument whenever the tape is entirely wound up, or entirely run down, and is opened during the operation of the instrument to lock the other instruments. The invention further consists in the combination, with the main drum or spring-shaft carrying a pinion, of a rack-bar that engages with a shoulder upon the stop of the armature to prevent the operating instrument from locking itself.

In the drawing, A represents the positive and A' the negative pole of the instrument, which pass the current through the signaling or perforated tape, and is connected with the central battery and an alarm-bell at the central and other alarm-stations, and forms the

main line. B is the positive and B' the negative pole of the non-interference and secondary circuit, which controls the locking of the instruments, and is electrically connected with an independent central battery, and each of the signal-station instruments, and with the central alarm and other stations. C C' are drums journaled in supports, and provided with pinions D D', which mesh with a central toothed wheel, E. Said wheel has attached to its shaft a rigidly-attached crank, F, carrying a pin, e , and also a loosely-moving bifurcated lever, G, which turns the crank in one direction, and moves independently of it in the other. The said crank has an extension, H, which moves between the adjustable set-screws I I and regulates the throw of the lever. J is a non-conducting tape, perforated with holes to represent the number of the signal-box, which is wound upon the drum C when the lever is deflected, and upon the drum C' when the instrument is spent. A spring-seated and platinum-faced contact-wheel, K, is connected by a wire, a^1 , with the pole A' of the main line, and a contact-roller, K', communicating with the roller K through the perforations, is connected with the pole A of the main line through wire a . When the instrument is not in operation the current is shunted from the rollers by wires a^2 and a^3 , and an insulated spring-seated pawl, d , that closes the circuit, by engaging with a stud upon the main wheel of the clock-gearing, which device is more particularly described and claimed in my patent No. 158,715. To prevent the interference between the signals of different instruments, which may be operated at the same time, a second tape, L, is placed upon the drums and operated with the other tapes. Said tape is perforated only at its extremities, and closes the secondary circuit of the poles B B', only when the instrument is entirely wound up or entirely run down. This tape is provided with contact-rollers M M', similar to those of the other tape, which are connected, M by a wire, b' , with the pole B', and M' by a wire, e , with the magnets N, and by wire b running therefrom with the pole B. O is an armature playing upon the magnets N, and having a lever-extension, P, to the upper end of which is attached a spring, Q, which, when the magnets are de-

magnetized by the breaking of the second circuit by the tape L of some other instrument, holds the armature away from the magnets, and forces a stop, R, at the lower end, into a fly, S, of the clock-gearing to stop its motion, and lock the instrument.

To prevent the operating instrument from locking itself as soon as its second circuit shall be broken by its tape L, the stop R is provided with a shoulder, *f*, behind which passes a rack-bar, *g*, operated by a pinion, *h*, upon the main shaft carrying the spring, whereby the stop is prevented from going into the fly after the magnets are demagnetized until the instrument is spent, and the stop in alignment with a notch in the said rack-bar.

When two instruments are pulled at the same time, the second one though locked may be set ready to operate in its turn, the rack-bar being provided with a spring, *i*, which allows the rack-bar a vertical motion, and permits it to mount the stop R in its locked position.

The operation of the instrument is as follows: When the instrument is not in use the main alarm-current is shunted from the contact-wheels and tapes by the wires $a^2 a^3$ and the contact of the stud upon the wheel of the clock-gearing, with the spring-seated insulated pawl. When the lever is pulled, this contact shunts the current until the tapes are unwound from one drum and wound up on another, and as soon as the stud leaves the said pawl the current is sent through the contact-wheels of the perforated signal-tape, and the signal indicating the position of the instrument sent to the central and other alarm-stations. While, however, the signals are being sent the secondary current is broken by the tape L, and, as a consequent result, the magnets of the operating, and all of the other, instruments being demagnetized, the stops of all the other instruments are driven in by the spring to lock the fly of the clock-gearing. The operating instrument is prevented from locking itself by the rack-bar, which, being behind the shoulder of the stop, prevents the same from being driven into the fly. If the lever of a second instrument be pulled before the first has finished, it remains locked until the first instrument is through, and its contact-rollers M M' close the second circuit through the perforation. When this

takes places the electro-magnets of the second instrument, being magnetized, with draw the stop of that instrument, and allows it to send its signals after the signals of the first have been recorded, so as to obviate any possibility of an interference. Should the levers of two separate instruments be pulled while the first is operating, they would both start upon the closing of the secondary circuit; but the one which first breaks the circuit again stops and locks the third until the said second one has recorded its signal and is through.

The instruments, as thus described, are to be fitted with bell-magnets or sounders for the main alarm-circuit, and the secondary wire is provided with a closed key and bell-magnet or sounder, which, when the instruments are not in use while an alarm of fire is being transmitted, may be employed for police or other purposes between police-stations, and may be used from the fire-instruments to police-stations, or to other fire alarm instruments and to the central station, either by the use of the Morse alphabet or a code of tap-signals.

Having thus described my invention, what I claim as new is—

1. The herein-described method of preventing interference of signals by connecting the instruments at the various signal-stations by a second and independent electric circuit, which is opened or closed automatically, and operates the armature of an electro-magnet carrying a stop for the purpose of locking the clock mechanism to prevent the interference of signals, substantially as described.

2. The herein-described method of automatically operating the armature provided with a stop for the clock-gearing, by a non-conducting-tape disposed and operated upon the same drums with the signal-tapes, and having perforations at its extremity only, whereby the secondary circuit is closed when the instrument is not in operation, and is broken while the instrument is in operation, substantially as described.

3. The stop R, having the shoulder *f*, in combination with the rack-bar *g*, spring *i*, and pinion *h*, substantially as and for the purpose described.

JOSEPH W. KATES.

Witnesses:

R. M. J. PAYNTER,
S. MCG. FISHER.