

A. T. LARGE.  
Window-Scaffold.

No. 165,594.

Patented July 13, 1875.

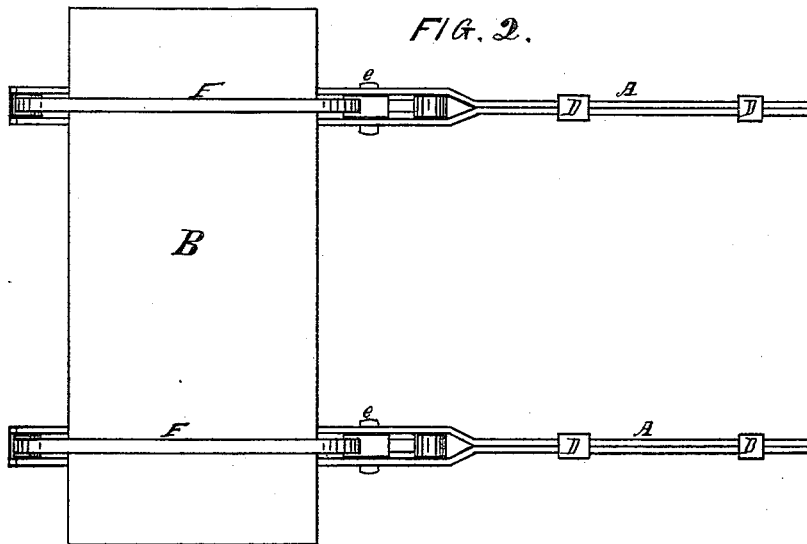
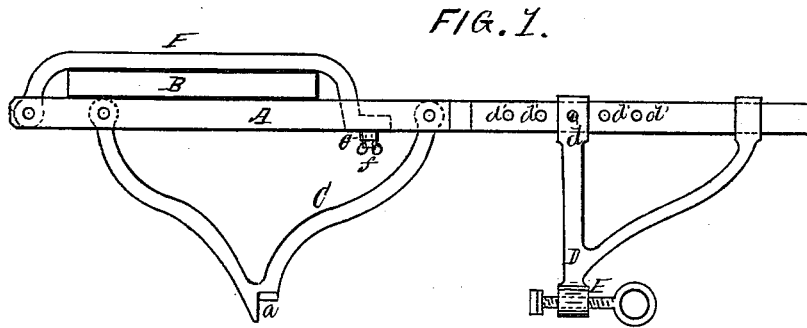

Witnesses:  
E. S. Sherburne,  
F. C. Goodwin

Inventor:  
Andrew T. Large,  
per Sherburne & Co.  
Attorneys.

# UNITED STATES PATENT OFFICE.

ANDREW T. LARGE, OF CHICAGO, ILLINOIS.

## IMPROVEMENT IN WINDOW-SCAFFOLDS.

Specification forming part of Letters Patent No. 165,594, dated July 13, 1875; application filed April 14, 1875.

*To all whom it may concern:*

Be it known that I, ANDREW T. LARGE, of Chicago, in the county of Cook and State of Illinois, have invented a new and useful Window-Scaffold; and I do hereby declare the following to be a full, clear, and exact description thereof, which will enable others skilled in the art to which it appertains to make and use the same, reference being had to the accompanying drawing forming part of this specification, in which—

Figure 1 is a side elevation of a window-bracket embracing my said invention, and Fig. 2 is a top view of the same with platform attached.

Similar letters of reference indicate like parts in both figures of the drawing.

My invention has for its object to provide an improved means for supporting a platform on the outer side of a building, upon which a person can stand with safety when cleaning the outer surface of a window, thereby enabling the person to clean both sides of the window without removing it from the frame; and to that end it consists in a hinged clamp-bar for securing the platform to the staging, as will be more fully understood by the following description and claim.

In the drawing, A represents the bracket proper, which consists of two wrought-iron bars connected to each other, so as to form a space between them, and of the requisite length to extend across the window-sill and project outward from the wall of the building a sufficient distance to receive the platform B. Permanently attached to the outer end of the bracket is a depending brace, C, the lower end of which is notched to fit the corner of the window-sill, as shown at *a*, Fig. 1. Loosely attached to the inner end of the bracket is a depending brace, D, which is so arranged as to admit of being moved toward or from brace C, and firmly secured at any requisite point by bolt *d*, the latter passing through one of

the apertures *d'* in the bracket, and through the upper end of the brace, as shown in Fig. 1. The lower end of brace D is provided with a set-screw, E, which is arranged in line with notch *a* of brace C.

The arrangement of the parts is such that when the bracket is passed through the window-opening, and the notch of brace C adjusted to the outer corner of the window-sill, and brace D adjusted to a point near the inner surface of the window, the whole is secured in a fixed position by simply turning the screw, so that its end impinges the inner surface of the window-casings.

Hinged to the outer end of the bracket, and between the side bars of the same, is a curved clamp-bar, F, which extends forward toward the center of the bracket, over the platform, as shown in Fig. 1. The inner end of this bar is bent downward, so as to pass between the side bars, and is provided at the lower end of its bent portion with a button, *e*, which bears against the lower edge of the side bars when turned across the same. Attached to the lower end of the pivot on which this button turns is a thumb-screw, *f*, which, when tightened, causes the clamp-bar to tightly embrace the platform, holding the latter in position.

In order to support the platform in a level position, it is necessary to use two brackets, one in each side of the window-opening; but, as both are the same in construction, I have mentioned but one of them in the previous description.

Having thus described my invention, I claim—

In combination with bracket A and platform B, the hinged clamp-bar F, arranged to embrace and hold the platform, as specified.

ANDREW T. LARGE.

Witnesses:

J. T. WHIPPLE,  
N. H. SHERBURNE.