

J. P. MITCHELL.

Boot and Shoe Crimping-Machine.

No. 165,605.

Patented July 13, 1875.

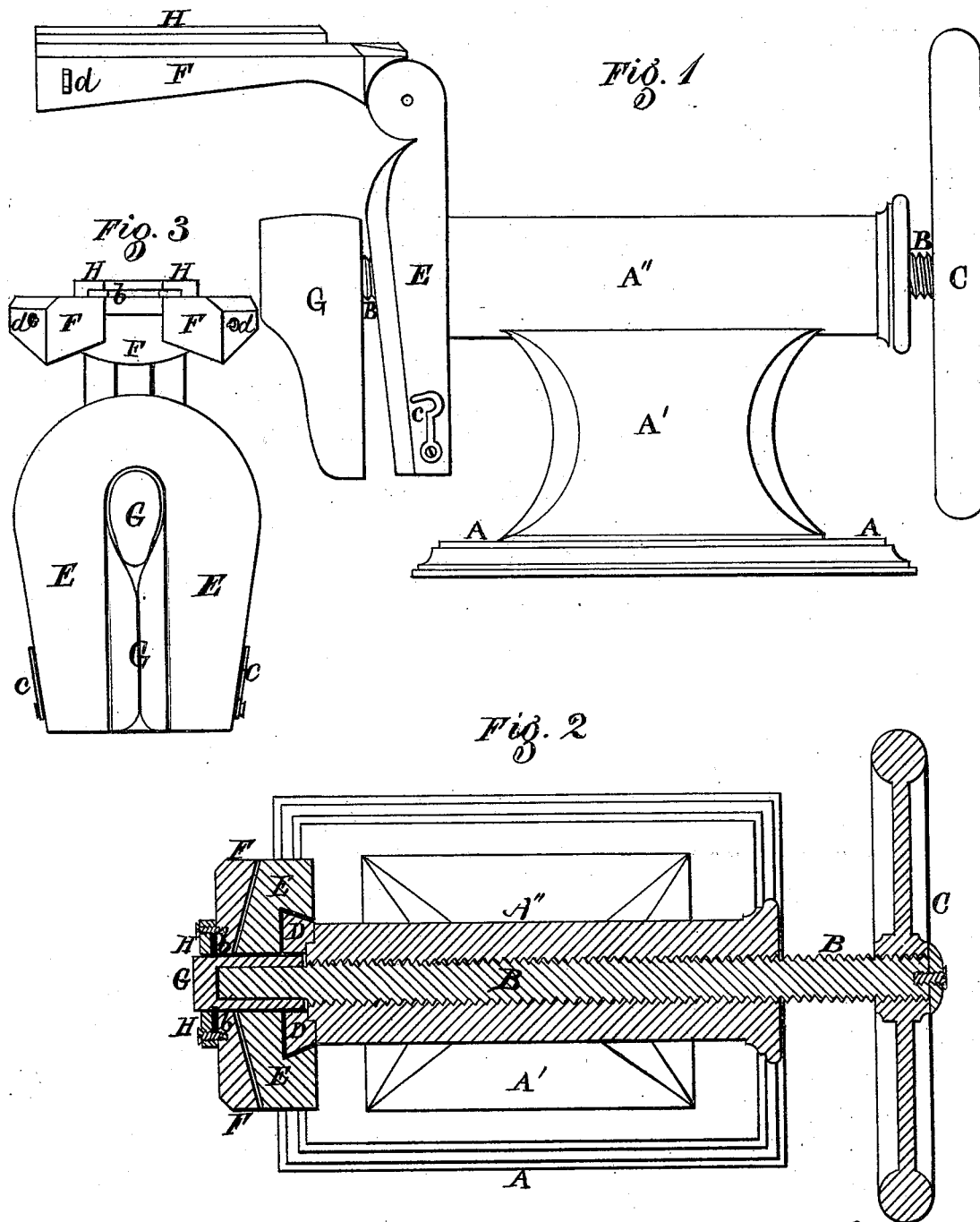

Witnesses  
Oren W. Weaver.  
Chas. Felton Ridgway.

Inventor  
Joseph P. Mitchell  
by his Attny  
Sam<sup>r</sup>. M. Barton

# UNITED STATES PATENT OFFICE.

JOSEPH P. MITCHELL, OF NEW BEDFORD, ASSIGNOR TO WILLIAM A. BROWN,  
OF LYNN, MASSACHUSETTS.

## IMPROVEMENT IN BOOT AND SHOE CRIMPING MACHINES.

Specification forming part of Letters Patent No. **165,605**, dated July 13, 1875; application filed  
February 19, 1875.

*To all whom it may concern :*

Be it known that I, JOSEPH P. MITCHELL, of New Bedford, in the county of Bristol and State of Massachusetts, have invented certain Improvements in Boot and Shoe Crimping Machines, of which the following is a specification:

Figure 1 of the accompanying drawings is a side view of my improved crimping-machine with the outer jaw or clamp raised. Fig. 2 is a central longitudinal vertical section of the same with the jaw or clamp closed. Fig. 3 is an end view of a portion of the machine with the jaw or clamp raised.

The present invention relates to certain new and useful improvements in machines for crimping boots and shoes, applicable, in the present instance, to crimping "seamless uppers;" and to this end my invention consists, mainly, of two peculiarly-shaped hinged bifurcated jaws or clamps, arranged and operated as will be hereinafter more fully explained, to hold and stretch the leather as it is pressed through the bifurcations of said jaws or clamps, to crimp it in the desired shape, by a "former" or last, adjusted to and impelled by the action of a longitudinal screw-shaft, operating in a suitable stand, supporting at one end a vertical frame, arranged to hold or allow the ready removal of one of the jaws or clamps. This invention also consists of a rubber or other elastic or yielding smoother, attached to, so as to be readily removed from, the outside of the outer jaw or clamp, around its bifurcation, to give a uniform pressure and final finish to the leather or other material, all of which I will now proceed to more particularly describe.

In the drawings, A represents the bed, and A' the standard of a metallic or other suitable cylindrical or other desired shaped longitudinal stand, A'', formed with a central interior screw-aperture, which receives a longitudinal screw-shaft, B, provided on one end with a wheel, C, or other operating device, and at the other end connected with so as to support a vertical frame, D, beveled on the sides, or otherwise formed to receive, hold, and allow the adjustment or removal of a metallic or other suitable jaw or clamp, E, formed at

the top to receive the pivot and hinged top portion of an outer metallic or other jaw or clamp, F. These clamps or jaws E F are bifurcated or slotted in the center to receive and allow the passage of a "former" or last, G, which is adjusted on one end of the screw-shaft B. The inner or supported jaw or clamp E is convexly or outwardly curved on its upper interior face, the downward continuation of the interior face being beveled or inclined transversely from the edge of the bifurcation or slot to the sides of the jaw or clamp E, whose top is of a semicircular shape, as is the top of the jaw or clamp F, which jaw or clamp F is beveled and curved on its inner face reversely to, so as to fit when closed over, the jaw or clamp E. Surrounding the slot or bifurcation of the jaw or clamp F, on the outside, is a rubber or other yielding smoother, *b*, held so as to be readily replaced by a curved or desired shaped rabbeted or other suitable clamp or frame, H, secured to the clamp F by screws or otherwise. The clamps E F, when brought together, are held by a hook and staple, *c d*, or otherwise held together, as preferred.

The operation of my invention is as follows: The former or last G, to which the "upper" or other stock or material, cut as desired, is secured by a clamp or otherwise, is adjusted on the end of the screw-shaft B. The jaw or clamp F is then brought down upon the jaw or clamp E, so as to hold the "upper" or other stock or material between their beveled and curved faces. The jaws or clamps are fastened together by the bottom hooks or bolts, or otherwise secured, and power being applied to the screw-shaft B, it is rotated and carries the former or last G, and leather or other material thereon, through the bifurcations or slots of the jaws E F, whose faces clamp, so as to hold and stretch and compress, the material, and prevent its wrinkling or plaiting while the "former" is progressing, and molding it in the proper form through the bifurcations or slots of the jaws E F, the rubber or other elastic or yielding smoother *b* bearing uniformly on the material, and giving it final finish as it passes from the outer jaw F; thus forming the "upper" of one seam-

less piece in the desired shape, in an expeditious, smooth, and finished manner, as will be readily seen on examination without further explanation.

Having thus described my improvements, what I claim as my invention, and desire to have secured to me by Letters Patent, is—

1. In a machine for crimping boots and shoes, hinged bifurcated jaws or clamps E F, curved and beveled on their interior faces, as shown, to fit one on the other and hold the material, to prevent its wrinkling as it is passed on a suitable former or last through the bifurcations of the jaws or clamps, substantially as specified.

2. In a boot and shoe crimping machine, in combination, the longitudinal screw-shaft B, former or last G, and bifurcated jaws E F, all substantially as and for the purpose described.

3. In a boot and shoe crimping machine, a rubber or yielding smoother attached to, around the bifurcations of, the jaw or clamp F, in combination with jaw or clamp E, former or last G, and screw-shaft B, all constructed substantially as and for the purposes specified.

4. The combination of the clamps or jaws E F, frame D, former or last G, screw-shaft B, and stand A'', all operating substantially as and for the purposes herein set forth.

In testimony whereof I have signed my name to this specification in the presence of two subscribing witnesses.

JOSEPH P. MITCHELL.

Witnesses:

WENDELL H. COBB,  
ROBERT R. SHERMAN.