

W. WESTCOTT. Heel Polishing Machine.

No. 165,640.

Patented July 13, 1875.

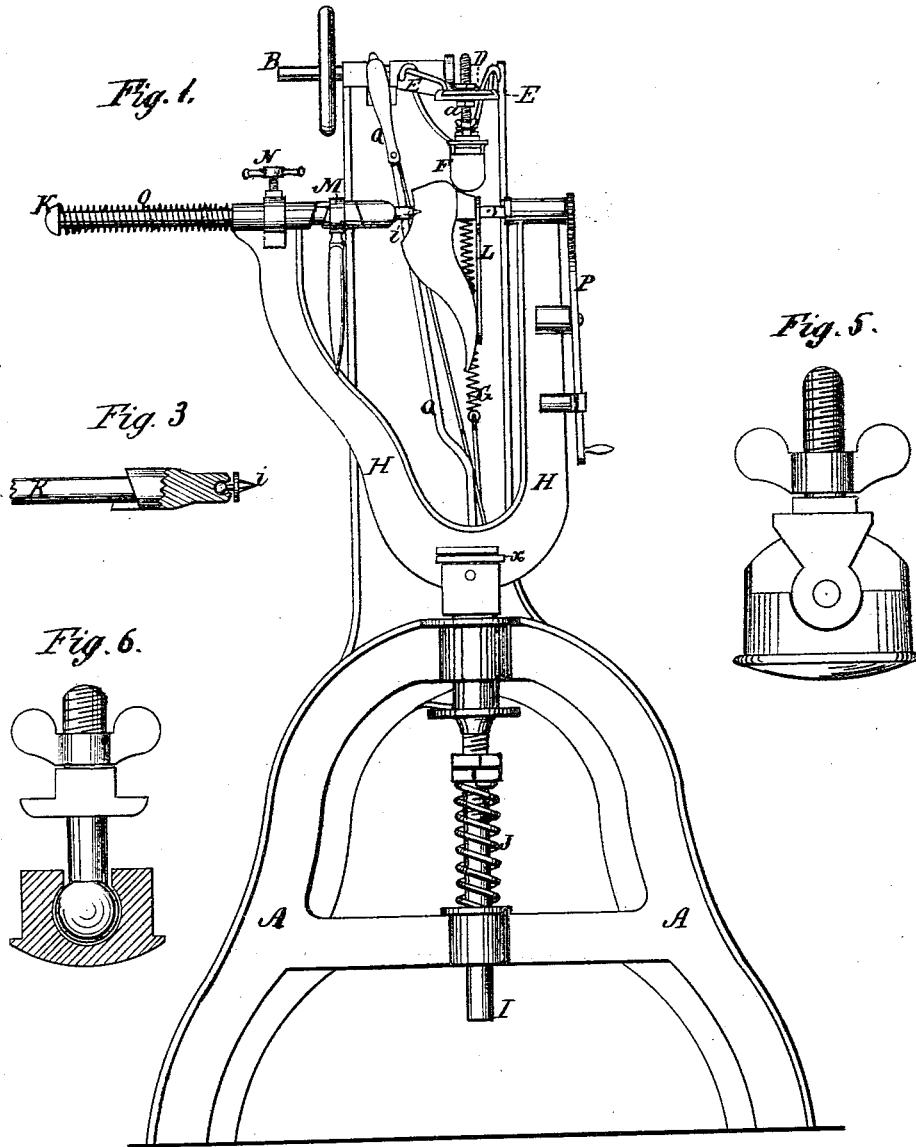

WITNESSES:
W. W. Hollingsworth
John Kemon

INVENTOR:
Wm Westcott
 BY *Wm T B*
 ATTORNEYS.

W. WESTCOTT.
Heel Polishing Machine.

No. 165,640.

Patented July 13, 1875.

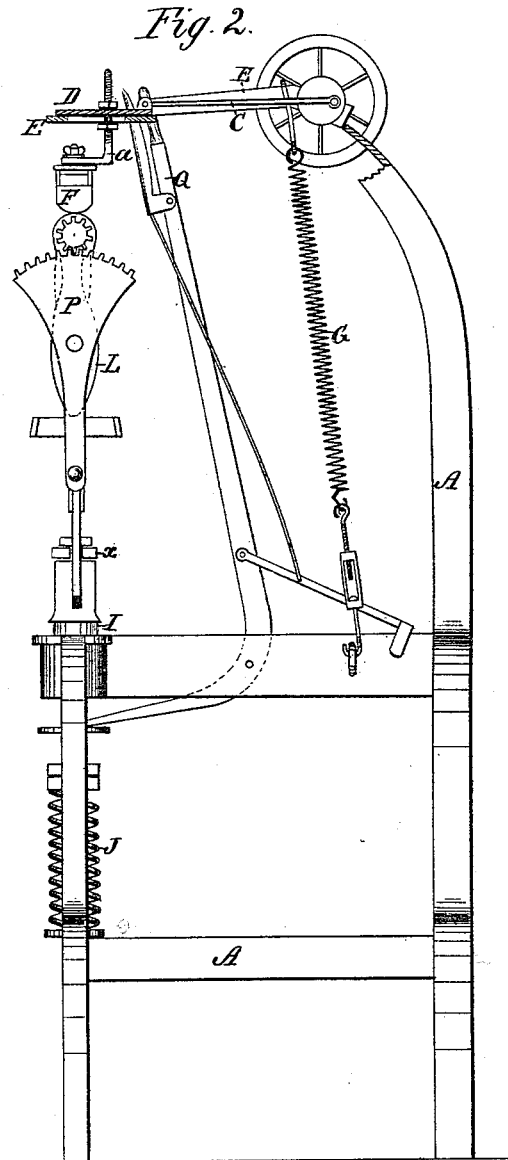

WITNESSES:
W. W. Hollingworth
John Kerson

INVENTOR:
Wm Westcott
BY *Allen B*

ATTORNEYS.

UNITED STATES PATENT OFFICE,

WILLIAM WESTCOTT, OF SYRACUSE, NEW YORK.

IMPROVEMENT IN HEEL-POLISHING MACHINES.

Specification forming part of Letters Patent No. 165,640, dated July 13, 1875; application filed June 10, 1875.

To all whom it may concern:

Be it known that I, WILLIAM WESTCOTT, of Syracuse, in the county of Onondaga and State of New York, have invented a new and Improved Heel-Polishing Machine; and I do hereby declare that the following is a full, clear, and exact description of the same, reference being had to the accompanying drawing, forming a part of this specification, in which—

Figure 1 is a vertical front elevation; Fig. 2, a vertical side elevation, partly in section; Fig. 3, a vertical detail, showing connection of stud *i* with shaft K; Fig. 4, a detail of the polishing-tool; Fig. 5, a detail of polishing-tool, showing a metallic block; Fig. 6, a sectional detail of a modification of the polishing-tool, showing a ball-and-socket joint in a metallic block as adapted to ladies' shoes.

This invention relates to certain improvements in machines for polishing the heels of boots and shoes; and it consists of a branched frame which carries the shoe-holding devices, which frame is located just beneath the polishing-tool and is pivoted upon horizontal pivots to a vertical rod, which is attached to the frame-work by a swivel-joint and is held up by a spiral spring. In one end of the branched rod is an adjustable spring-seated rod regulated by a cam and set-screw, which said rod enters a socket of the last and presses the heel of the shoe against a pivoted plate. The invention also consists in the combination with the shoe-holding devices and the branched frame of a hand-lever and pawl for withdrawing the shoe from the polishing-tool, and in the peculiar construction of the polishing-tool, in which a soap-stone block is provided with side plates to which the support is pivoted to prevent wearing the said block.

In the drawing, A represents a frame of cast-iron, or other suitable material, carrying at the top a revolving shaft, B, which is geared with the actuating mechanism by any suitable means. C is a short pitman which is connected with the shaft B through a wrist-pin or crank at one end and to a reciprocating-slide, D, at the other. E is a guide which contains the slide D at one end, and is pivoted at the other upon the same axis with shaft B. A support, *a*, is adjustably attached to the

slide D through a slot in the bottom of the guide and to the same is fastened the polishing-tool F. The said polishing-tool consists of a soap-stone block, *b*, side plates *c* attached thereto by screws and a pivoted attachment, *d*, which is fastened to support *a*, the side plates serving to prevent the wear of the block from the friction of the same against the pivoted attachment. G is a spiral spring which is attached to the guide E and presses the reciprocating polishing-tool upon the heel of the shoe. H is the branched frame which carries the shoe-holding devices, and I is a vertical rod to which said frame is pivoted so as to rock in vertical planes, an elastic cushion, *x*, of rubber or other suitable material being interposed between a flange of said frame and the top of the vertical shaft. The object of this cushion is to restore the frame to its original position after moving the same to bring different parts of the heel under the polishing-tool. The rod I is fastened to the frame by a swivel joint, so that the frame carrying the shoe may be turned upon a vertical axis as well as upon a horizontal one. The said rod is provided with a spiral spring, J, which acts in connection with the spring G to render the pressure of the polishing-tool upon the heel, always elastic and uniform. K is an adjustable horizontal rod contained within one of the branches of the frame H, and L is a pivoted spring-plate attached to a shaft contained in the other branch of the said frame. This said plate and rod together hold the shoe between them beneath the polishing-tool, the plate L receiving the sole of the shoe and the end of the rod entering a socket in the last. The said end of the rod consists of a stud, *i*, which is held in the rod by a ball-and-socket joint to allow perfect freedom of motion in turning the shoe during the polishing operation. The rod K is made to clamp the shoe by a cam-sleeve, M, and is held in such position by a set-screw, N, a spiral spring, O, serving to retract it when the shoe is to be removed. In turning the shoe upon its clamping-rod and plate it will probably be found best to turn the same by working the shoe itself; but a segment-headed lever, P, is also used for this purpose, which meshes with a pinion upon the same shaft with plate L. Q

is a hand-lever and pawl pivoted to the framework and connected with the rod I, whereby the shoe and its clamping devices may be withdrawn from the polishing-tool.

By means of the above-described devices any part of the heel of a shoe may be brought under the polishing-tool, the said shoe having an adjustment in a vertical plane upon its clamping-rod, an adjustment in a vertical plane upon its branched frame, and a further adjustment in a horizontal plane upon the vertical rod I.

Having thus described my invention, what I claim as new is—

1. The combination of the side plates *c*, with the soap-stone block *b*, and the pivoted attachment *d*, as and for the purpose specified.

2. The pivoted branched frame H, in combination with the shoe-holding devices and

the elastic cushion *x*, as and for the purpose set forth.

3. The swivel-jointed rod I, having spring J, in combination with the pivoted branched frame H, as and for the purpose described.

4. The hand-lever and pawl Q, in combination with the rod I, and frame H, substantially as and for the purpose described.

5. The shoe-holding devices, consisting of the pivoted plate L, the rod K, cam-sleeve M, spring O, and set-screw N, all combined and arranged substantially as and for the purpose described.

The above specification of my invention signed by me this 3d day of June, 1875.

W. WESTCOTT.

Witnesses:

SOLON C. KEMON,
CHAS. A. PETTIT.