

J. E. WOOTTEN.

Car-Spring.

No. 165,647.

Patented July 13, 1875.

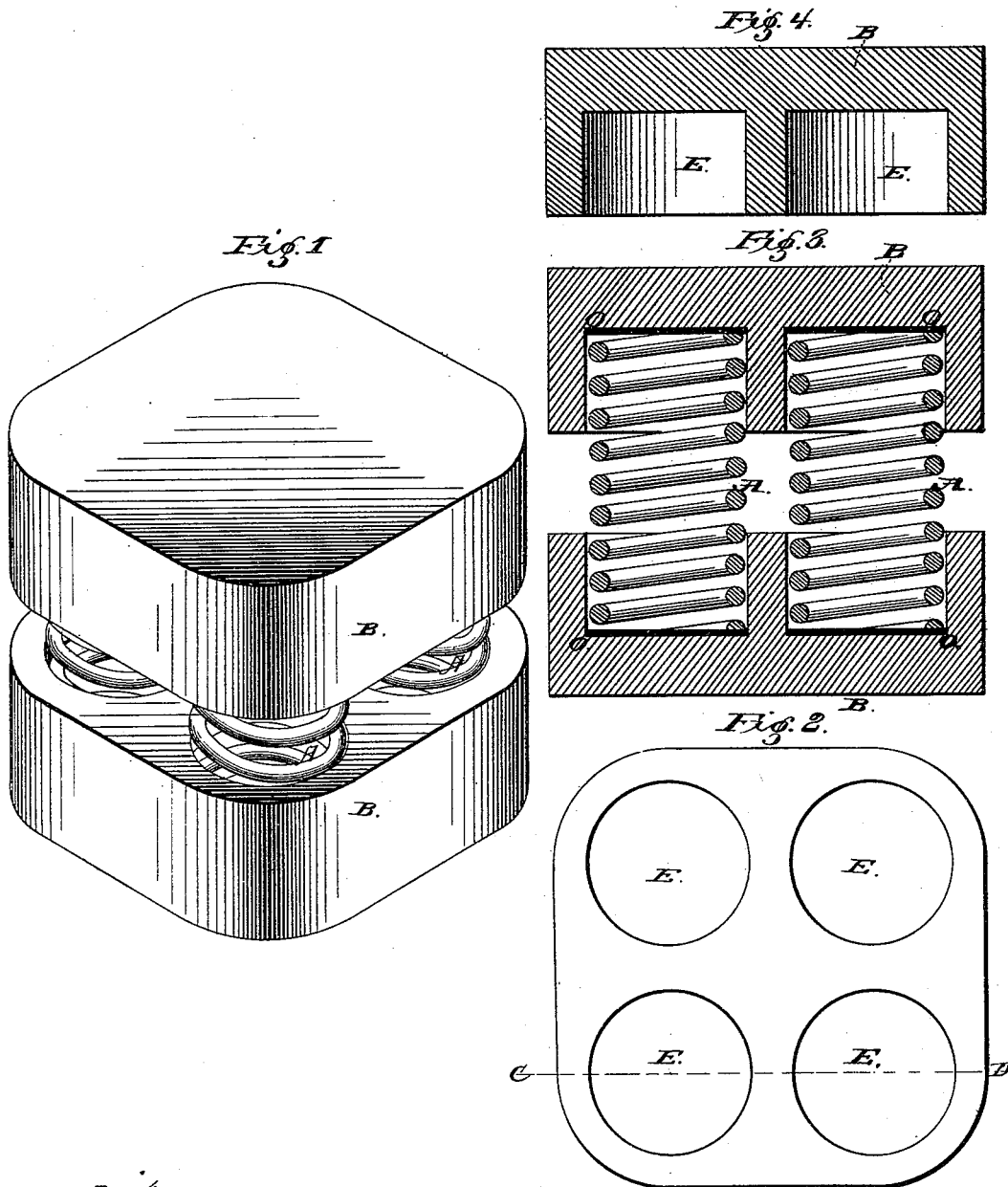

Witnesses:
Geo M. Laidis.
Edw H. James

Inventor:
John Eastburn Wootten.

UNITED STATES PATENT OFFICE.

JOHN E. WOOTTEN, OF READING, PENNSYLVANIA.

IMPROVEMENT IN CAR-SPRINGS.

Specification forming part of Letters Patent No. **165,647**, dated July 13, 1875; application filed February 14, 1874.

To all whom it may concern:

Be it known that I, JOHN E. WOOTTEN, of Reading, Berks county, Pennsylvania, have invented an Improvement in Car-Springs, of which the following is a specification:

My invention relates to that class of car-springs which consist of spiral springs combined with cellular blocks or plates; and the object of my invention is to make a light and cheap spring of this class, and one in which the spirals will not be abraded by the cells in which they are lodged.

This object I attain in the manner which I will now proceed to describe, reference being had to the accompanying drawing, in which—

Figure 1 is a perspective view of my improved car-spring; Fig. 2, a plan view of the same; Fig. 3, a sectional elevation on the line C D, and Fig. 4 is a sectional view of one of the cellular blocks of wood.

A A A A are spiral springs, of steel or iron or other suitable metal; and B B are blocks of wood, in which are made cylindrical cells E of a suitable diameter to receive the springs, and of a proper depth for steadying the same. Metallic plates O are interposed between the ends of the spirals and bottoms of the cells for preventing the former from penetrating the wood.

In the drawing I have shown the cells to be of equal depth in both blocks, but the cells may be deeper in one block than in the other. In all cases, however, the distance of the opposed faces of the said blocks from each other, when the spring is unloaded should be a little less than the range of elasticity of the spirals,

so that the faces of the blocks may come in contact with each other before the spiral springs are too closely compressed.

It is also desirable that the spiral springs should have as little lateral play as possible in their respective cells, so that their perpendicularity may be maintained under pressure, and their full strength consequently utilized, and so that the entire spring may be capable of resisting ordinary lateral shocks without injury to its structure.

The cellular wooden blocks viewed in connection with the spirals possess not only the advantages of being much lighter and cheaper than cellular metal plates, but they possess the further advantage of preventing that abrasion and consequent injury of the spirals which must necessarily take place if they were confined to metal cells, for while the spirals have but little tendency during their movement, consequent upon the alternating compression and recoil, to injure the wood, more or less of the end grain of which is presented to the spirals, the latter cannot be injured by the wood.

I make no broad claim to a spring composed of spirals confined to cells in plates; but

I claim as my invention—

The combination of the series of spirals, the wooden cellular blocks, and metallic plates interposed between the bottoms of the cells and the ends of the spirals, as specified.

JOHN EASTBURN WOOTTEN.

Witnesses:

JAS. M. LANDIS,
EDW. W. JAMES.