

J. C. GARRETSON.  
 Wheel for Vehicles.

No. 165,924.

Patented July 27, 1875.

Fig. 1.

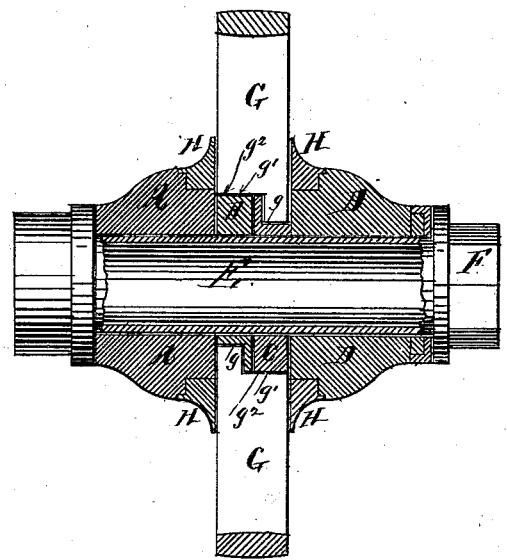

Fig. 2.

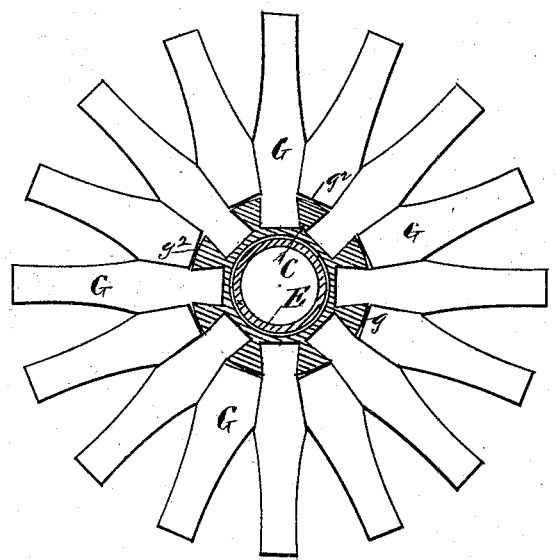

Fig. 3.

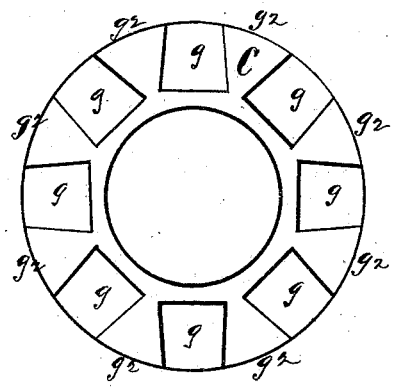
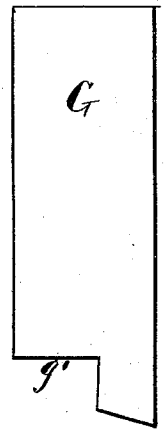

Fig. 4.



Witnesses:  
 Franklin Parrott.  
 Richard Gesner.

Inventor:  
 Jacob C. Garretson,  
 Per,  
 Henry Gesner,  
 Atty

# UNITED STATES PATENT OFFICE.

JACOB C. GARRETSON, OF MARSHLAND VILLAGE, NEW YORK.

## IMPROVEMENT IN WHEELS FOR VEHICLES.

Specification forming part of Letters Patent No. **165,924**, dated July 27, 1875; application filed January 14, 1875.

*To all whom it may concern:*

Be it known that I, JACOB C. GARRETSON, of Marshland Village, in the county of Richmond, on Staten Island, in the State of New York, have invented a new and useful Improvement in Hubs for Wagon-Wheels; and I do hereby declare the following to be a full and clear description thereof, which will enable others to make and use my improved connection between the spokes and hub, by which the spokes are secured to metal rings surrounding the thimble or box of the hub, a portion of the end wood of the spoke resting squarely upon a plain surface of the ring, to which it is attached by dovetailing, the object being to support the spoke and keep it pressing outward firmly toward the periphery of the wheel, and preventing the spokes from crushing inward toward the hub as the wheel becomes worn.

I am aware that others have sought to accomplish the same result that I now obtain in this invention, and that among the patents granted for improvements on hubs, that granted to John J. Ralya, March 11, 1873, and numbered 136,761, contemplates the construction of a hub in several sections, and otherwise produces a result somewhat like that of my improvement, but in a different manner.

The interlocking of the spokes, which gives the wheel stability and strength, in the manner herein set forth, forms one of the special features in my invention. At the same time the whole arrangement in my improved wheel is simpler, less costly, and more efficient than others of similar construction.

I disclaim any part of my improvement which interferes with the rights granted to the said John J. Ralya or others. What I claim is the simplicity and originality of my invention, by which a better result is sought to be attained.

The invention will be readily understood by reference to the accompanying drawings, of which Figure I is a longitudinal sectional elevation of the improved hub. Fig. II is a transverse sectional elevation of the same; Fig. III a detached elevation of one of the rings to which the spokes are attached

when the parts are assembled. Fig. IV is an elevation of the spoke, showing a square shoulder, which is designed to be seated on the ring above mentioned.

The hub is composed of several pieces, A B C D, the two outer pieces, A D, being of wood, and the two inside pieces, B C, being of metal. The whole of these parts, being assembled together by means of the thimble or box E, which is secured firmly to the outer portion of the hub A, and passing through central apertures in the parts B C D, are held in place by the nut F, which secures the parts firmly together. The two rings B C are placed side by side, as in Fig. I, and each of them has dovetailed mortises or notches *g*, as seen in Fig. III, into which the spokes G are inserted. The depth of the mortises or notches *g* is only equal to one-third, more or less, of the width of the spoke G, so as to leave a shoulder, *g*<sup>1</sup>, by the side of the dovetailed tenon *g*<sup>2</sup>, the said shoulder *g*<sup>1</sup> being designed to rest firmly on the periphery of the rings B C, so as to hold the spoke firmly in its position at a certain fixed distance from the axis of the hub, and thereby keep the felloes of the wheel pressed out tightly to the tire. This construction will prevent the spokes from wearing loose in the hub, and a consequent loosening of the tire of the wheel from that cause. The hub will be strengthened by bands H placed around it contiguous to and pressing against the spokes, as shown in Fig. I. These bands will assist and brace the spokes against lateral displacement or deflection from their proper position. In assembling the parts the mortises or notches for the spokes will be arranged alternately on opposite sides of the ring B C, so as to allow ample room for the said mortise or notch and the tenon *g*<sup>2</sup> which is to be placed thereon. The ring B C may be formed in two separate pieces, or in one solid piece, the two pieces, however, being considered the preferable form of construction.

Having thus described my invention, I desire to claim—

1. The hub in separate parts A B C D, the parts B C having dovetailed mortises or

notches  $g$  for the reception of the spokes, and the whole held firmly together by means of the box or thimble  $E$  and nut  $F$ , as set forth.

2. The spokes  $G$ , with a dovetailed tenon,  $g^2$ , and a square shoulder,  $g^1$ , for the purpose of assembling the spoke with the hub, and

holding it firmly fixed thereon at a fixed distance from the axis of the hub, as set forth.

JACOB C. GARRETSON.

Witnesses:

ANTON C. CRONDAL,  
FRANKLIN BARRITT.