

J. GRZYBOWSKI. Pump.

No. 165,925.

Patented July 27, 1875.

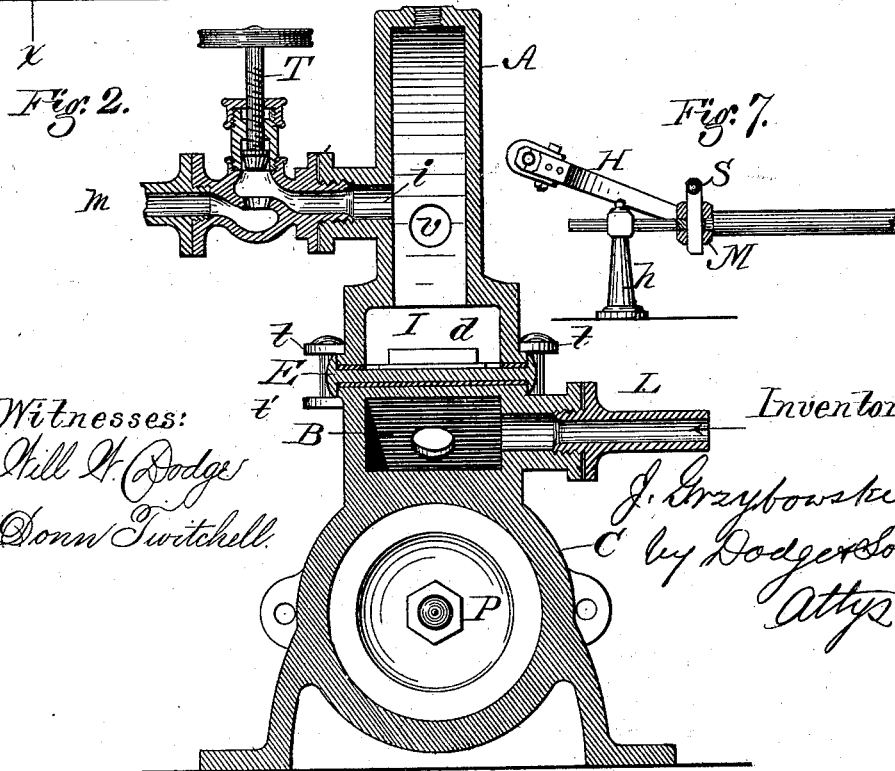
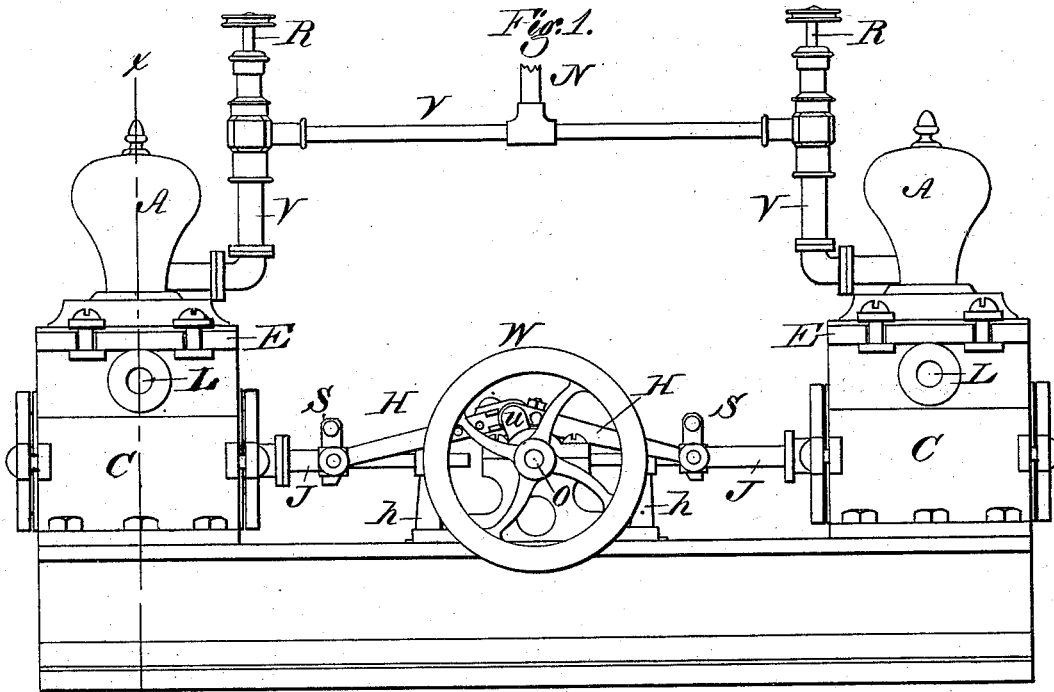

Witnesses:
 Will H. Dodge
 Donn Twitchell.

Inventor:
 J. Grzybowski
 by Dodgerson
 Atty

J. GRZYBOWSKI.
Pump.

No. 165,925.

Patented July 27, 1875.

Fig. 3.

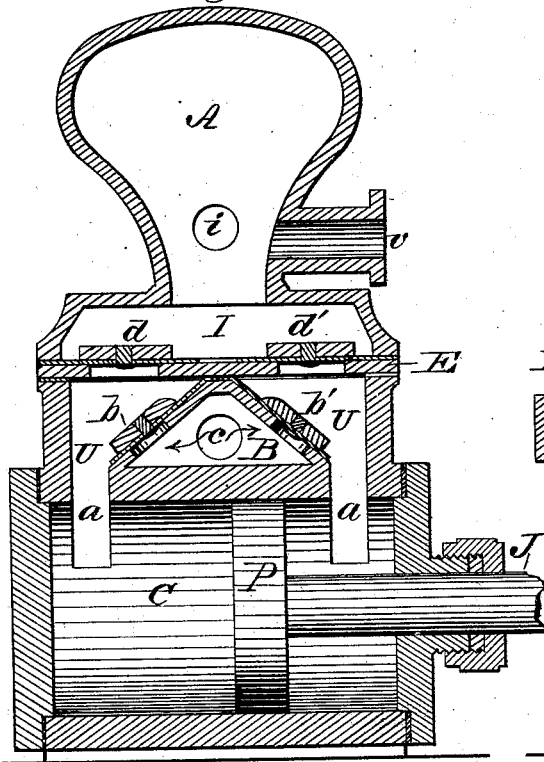

Fig. 4.

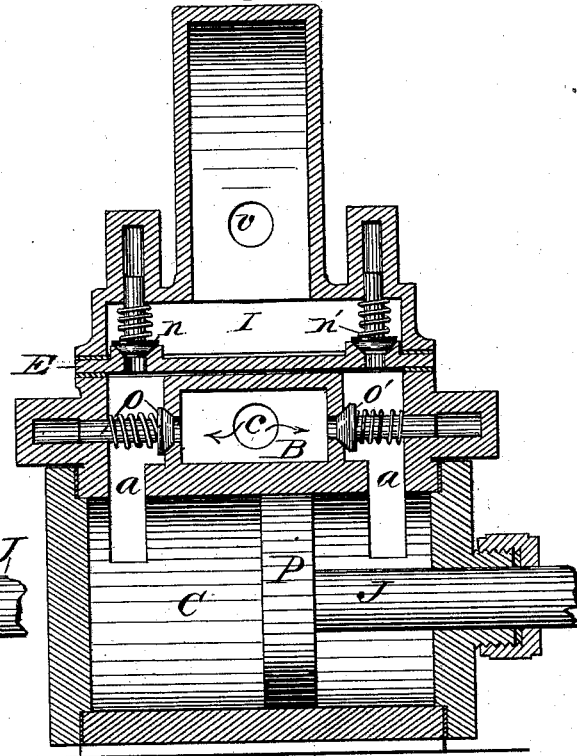

Fig. 5.

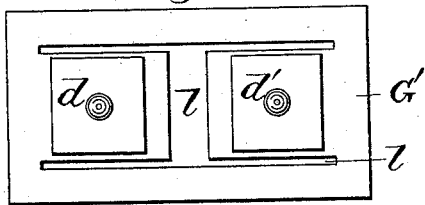
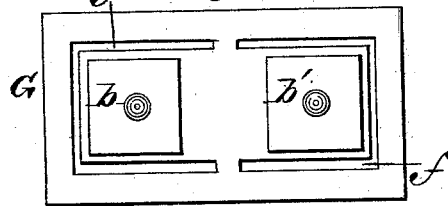

Fig. 6.



Witnesses:
Will H. Dodge

Inventor:
J. Grzybowski
by Dodge & Sons
Atty.

UNITED STATES PATENT OFFICE.

JULIAN GRZYBOWSKI, OF DETROIT, MICHIGAN.

IMPROVEMENT IN PUMPS.

Specification forming part of Letters Patent No. 165,925, dated July 27, 1875; application filed April 22, 1875.

To all whom it may concern:

Be it known that I, JULIAN GRZYBOWSKI, of Detroit, in the county of Wayne and State of Michigan, have invented certain Improvements in Pumping-Engine, of which the following is a specification:

My invention relates to pumps; and it consists of two pumps arranged at opposite ends of a common frame or bed, both driven from the same crank, and each arranged to be disconnected at will, and the other used alone, together with outlet-pipes arranged so that the stream of water can be thrown from either one or both separately, or from both through one common delivery. It further consists in certain novel features of construction in the pumps themselves, all as hereinafter more fully described.

Figure 1 is a side elevation of the apparatus as a whole ready for use. Fig. 2 is a transverse vertical section on the line *x x* of Fig. 1. Fig. 2 is a longitudinal vertical section of one of the pumps; and Fig. 4 is a similar view of the same, showing a modification of the valves. Figs. 5 and 6 are plan views of the valves and packing detached, and Fig. 7 a portion shown in detail.

In constructing my improved apparatus, I provide a cylinder, C, with a piston, P, as represented in Fig. 3. On the top of the cylinder I construct a triangular chamber, B, with an inlet-opening, *c*, and two outlet-openings, having valves *b* and *b'* arranged over them, and opening into a chamber, U and U', at the sides, these latter being connected to the cylinder by passages *a* and *a'*, as shown. The top of these chambers is formed by a detachable plate, E, having ports in it, with valves *d* and *d'* arranged thereon, and opening into another chamber, I, to the upper part of which is connected an air-chamber, A, there being an outlet-opening, *i*, at the side, and another one, *v*, at right angles thereto, as shown in Figs. 2, 3, and 4. The lower set of valves *b* and *b'* I construct by taking a sheet of rubber or leather of the proper size to cover the doubly-inclined top of the chamber B, as represented by G, Fig. 6; and after securing thereon the metal valve-plates *b* and *b'*, I cut slits *f*, as shown, around the plates on three of their sides, leaving it uncut across the cen-

ter, at the point where it rests on the apex of the top of chamber B, this sheet G thus forming a packing for the valves, and also at the point where the plate E bears upon it, between the chambers U and U', and also between the plate E and the top of the chamber-walls, as shown in Fig. 3. The upper set of valves, *d* and *d'*, are constructed in a similar manner, as shown in Fig. 5, the sheet of rubber G' having a slit, *l*, cut at each side, and also being cut away at the center, thus leaving the valves attached at their outer edges, instead of at the center, as the others were. This sheet G' is laid flat on the plate E, and serves as a packing for the walls of the chamber I, where they rest on plate E, as well as packing and hinges for the valves. As shown in Fig. 2, the chamber I and the air-chamber A are cast in one piece, with ears *t* at the sides, by which it is bolted to the top of the chambers U and U', which is, in like manner, provided with corresponding ears *t'*.

It will be seen that by this construction access is had to all the valves by simply removing the air-chamber, the plate E resting loosely between it and the chambers below, so it can be lifted off as soon as the top is removed. If preferred, puppet-valves *o* and *n* may be substituted, as shown in Fig. 4, the construction being otherwise the same.

The operation of a pump thus constructed will be readily understood by any one familiar with such machines, and need not, therefore, be described.

Having constructed two such pumps, I mount them at opposite ends of a suitable frame or base, as shown in Fig. 1, with the end of the piston-rod J of each working in a stationary post or guide, *h*. Midway between the two pumps I mount a shaft, O, having a balance-wheel, W, and a crank, *u*. To the crank on opposite sides I attach a connecting-rod, H, which is made to straddle the piston-rod J, and which is connected at its end to a cross-head, M, which slides freely on the piston-rod when not fastened, these parts being shown detached in Fig. 7. The cross-head is connected to the piston-rod J by a key, S, which can be readily withdrawn, thereby releasing the cross-head M and its connecting-rod H from the piston-rod J whenever de-

sired, the cross-head playing back and forth on the rod J when thus released. It will thus be seen that either pump can be disconnected at will by simply withdrawing the key S, and thus either pump be used alone, or both together, as may be desired.

The two chambers A are each provided with a separate discharge-pipe, *m*, as shown in Fig. 2, it being provided with a valve, T, by which it can be closed at pleasure. From each chamber A there also extends a pipe, V, which joins at the center with a single discharge-pipe, N, each of the pipes V being provided with a valve, R, by which either or both may be closed at pleasure. By this arrangement it will be seen that water can be discharged direct from either chamber alone through its pipe *m*, or both may be made to discharge simultaneously through pipe N; or either may be shut off and the other alone made to discharge through the pipe N.

To operate the pumps, power is to be applied to the shaft O, which may be provided with suitable pulleys or gear-wheels for that purpose; or, if preferred, the shaft O may be provided with gear-wheels operating two separate crank-shafts, the connecting-rods H be-

ing connected separately to these crank-shafts, by which means the cranks can be set at any desired angle relatively to each other.

Having thus described my invention, what I claim is—

1. The combination of the two pumps, mounted on opposite ends of a common frame, the crank-shaft O, mounted midway between the two pumps, and the pitmen H, having their inner ends mounted on the crank, and their outer ends connected to the elongated piston-rods by means of the cross-heads M and keys S, as shown, so that either pitman may be disconnected and permitted to slide freely on the rod.

2. The combination of the two pumps, having their pistons both detachably connected to a common driving-shaft by mechanism substantially such as shown, and each pump being provided with two discharge-openings, *m* and *v*, the latter being united by a pipe, V, having cocks R, to a single pipe, N, as shown and described.

JULIAN GRZYBOWSKI.

Witnesses:

JOHN CHR. JACOB,
FRANK MELLIN.