

L. W. POND.
Saw-Mill Head-Block.

No. 165,946.

Patented July 27, 1875.

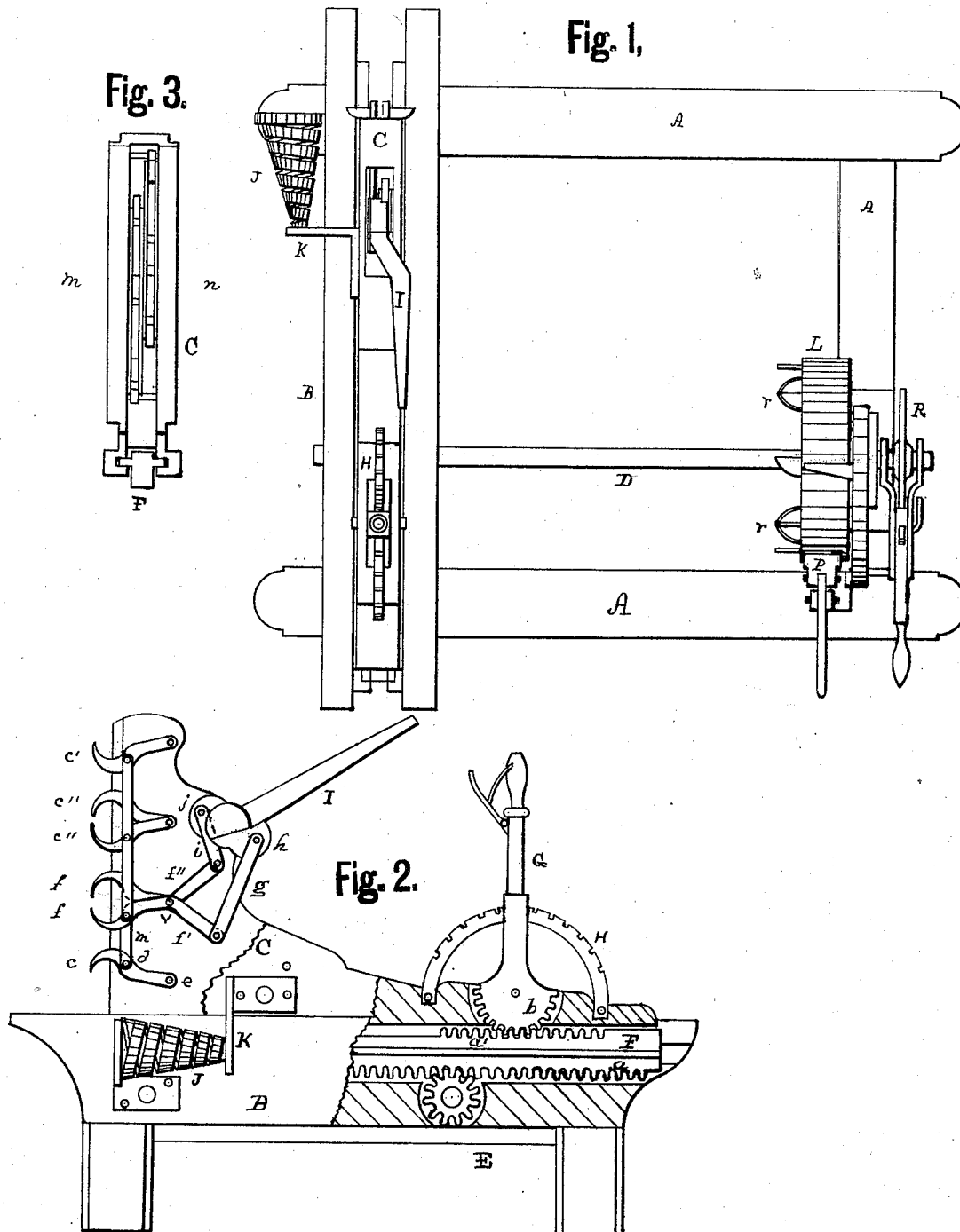

Witnesses:
George H. Christy.
L. W. Pond.

Inventor.
L. W. Pond.
By West & Bond, Atty.

UNITED STATES PATENT OFFICE.

LEVI W. POND, OF EAU CLAIRE, WISCONSIN.

IMPROVEMENT IN SAW-MILL HEAD-BLOCKS.

Specification forming part of Letters Patent No. 165,946, dated July 27, 1875; application filed April 6, 1875.

To all whom it may concern:

Be it known that I, LEVI W. POND, of Eau Claire, in the county of Eau Claire and State of Wisconsin, have invented new and useful Improvements in Saw-Mill Head-Blocks, of which the following is a full description, reference being had to the accompanying drawings, in which—

Figure 1 is a plan view, Fig. 2 a side view, of one head-block and jack, having portions cut away to show the interior, and Fig. 3 a front view of the jack.

I have shown in the drawings only one head-block and jack, though two or more of this style may be used, and in connection with the kinds now in use.

The chief object of this invention is to so construct the jacks or knees which carry the dogs that each one can be moved independently of the others, either forward or backward, without moving the set-works, and so that they can also be moved with the set-works.

This construction enables me to divide the taper of logs, to get the jacks up to and away from crooked logs, and to spring curved logs when long enough to rest on three or more head-blocks. Other objects are to improve the dogging devices and the set-works.

In the drawings, A represents the carriage of any desired length, and moved in the usual manner. B is one of the head-blocks, upon which the log is placed. C is one of the jacks or knees in which the dogging devices are placed. D is a set-shaft. E is a pinion on the set-shaft. F is a rack-bar connected with the jack. Heretofore the rack-bar has been rigidly secured to the jack; but this rack-bar F slides in grooves in the lower part of the jack. The pinion E engages with the rack *a* on the under side of the bar F. On the top of the bar F is another rack, *a'*, with which the toothed sector *b* upon the lower end of the hand-lever G engages. H is a notched bar, and in or connected with the lever G is a spring latch or catch to engage with the notches in H to hold the lever and sector *b* in any desired position. J is a strong spring upon the side of the head-block; and K is a piece of metal or other suitable material projecting from the jack to come in contact with the loose end of the spring J for the purpose

of taking up or preventing any play of the rack *a* and pinion. The jack moves in or upon the head-blocks as usual.

The operation of this part of my invention is as follows: When the lever G is held in any given position the jacks can be moved forward or back by means of the pinion and rack *a*, in the usual manner; and as a single shaft, D, is used with a pinion for each jack all the jacks must move together; but if the pinion be held fast, which can be done by means of a brake-wheel, L, on the shaft, or in some other manner, the jack can be moved either forward or back by means of the lever G and toothed sector *b*, which engages with the rack *a'*, and is pivoted to the jack, the whole rack F being prevented from moving, because the pinion E remains stationary, engaged with the rack *a*. Thus any one of the jacks can be moved independently of any of the others, and when all have been brought to position, they can be moved together, as usual, whether in line or not.

By this means I am able to bring all the jacks up to the log, whether it be straight or crooked, and can spring the log after it has been clogged by pushing up or drawing back one or more of these jacks, and without moving the set-works. By arranging or locating the bar F below the face of the head-block it will not interfere with the action of the jacks when it is advanced beyond their faces or fronts.

I have shown so-called rack-and-pinion set-works; but this improvement can, with slight modifications be applied where other kinds of set-works are used, such as rack and pawl, or screw, or others. Neither do I limit myself to the use of the lever G and sector *b* to move the jack. This may be done by a screw and nut, by a ratchet, or an eccentric, or by other well-known mechanical devices, so the joint may be between the rack and jack, or in the jack—that is to say, the rack may be permanently secured to the jack, and an independent joint may be located in the jack above the rack.

My dogging devices consist of two sets of dogs, each set placed in a movable frame, each dog or tooth being pivoted both in its frame and also to the jack, and two of the dogs being provided with rearward extensions piv-

oted to arms, which are pivoted to an operating lever. The frames may consist simply of strips of metal, between which the dogs are located.

m n represent these two frames. *c c'* are two dogs. *c* is pivoted in *m* at its lower end at *d*, and also to the jack at *e*. *c' c''* are two other dogs. One is pivoted in *m*, the other in *n*, and the rear ends of both are pivoted upon a single pin in the jack C. *f f'* are two other dogs, one pivoted in *m*, one in *n*, and both are pivoted at *v* upon a single pin in the jack. One has a rearward extension, *f''*, pivoted to an arm, *g*, which is pivoted to a projection, *h*, upon the lever I. The other has a similar extension, *f'''*, pivoted to the arm *i*, which is pivoted to a projection, *j*, upon the lever I, which lever is pivoted in the jack. One set of dogs are hooked in one direction, the other set in the opposite direction, as usual. By means of the single lever I both sets of dogs can be moved at the same time, one set, with their frame, moving in one direction, and the other in the opposite direction.

I do not confine myself to the number of dogs shown. A greater or a less number can be used.

The dog *c'* is pivoted in *n* and to the jack.

My improvement in the set-works consists in so constructing and arranging the dial-wheel that it can be used also as a brake-wheel, hand-wheel, and friction-wheel.

L is the dial-wheel secured to the set-shaft D. To it are secured a number of projecting arms, *r*. By taking hold of these arms the set-shaft can be reversed, and the jacks be drawn back by hand when the carriage is at

rest, or this can be done with the foot. P is a brake, which can be applied to the wheel L to prevent the shaft D from turning while the jack is being moved by means of the lever G and sector *b*, or by other equivalent device. R is a ratchet-wheel upon the shaft D, for the purpose of operating the set-works in the usual manner. The devices now in use to draw back the jacks when the carriage is in motion can be applied. L can be used as a friction-wheel substantially in the same way as such wheels are now used.

What I claim as new, and desire to secure by Letters Patent, is as follows:

1. The jack C, provided with a sliding or movable bar, operating below the face of the head-block and permitting the movement of each jack independently of the others, in combination with the head-block B, substantially as specified.

2. The independent spring J in combination with the head-block B and jack C, provided with an arm or stop, K, all arranged and operating substantially as specified.

3. The frames or bars *m n*, each having dogs *c c' c''* pivoted thereto, and also to the jack, in combination with the dogs *f f'*, with rearward extensions *f' f''*, arms *g i*, and lever I, substantially as and for the purposes specified.

4. The wheel L, provided with projections *r*, in combination with the set-shaft D, ratchet-wheel R, and brake P, substantially as specified.

LEVI W. POND.

Witnesses:

B. S. PHILLIPS,
O. S. VAN WAGENEN.