

C. FASOLDT.  
Tower Clock.

No. 165,991.

Patented July 27, 1875.

*Fig. 1.*

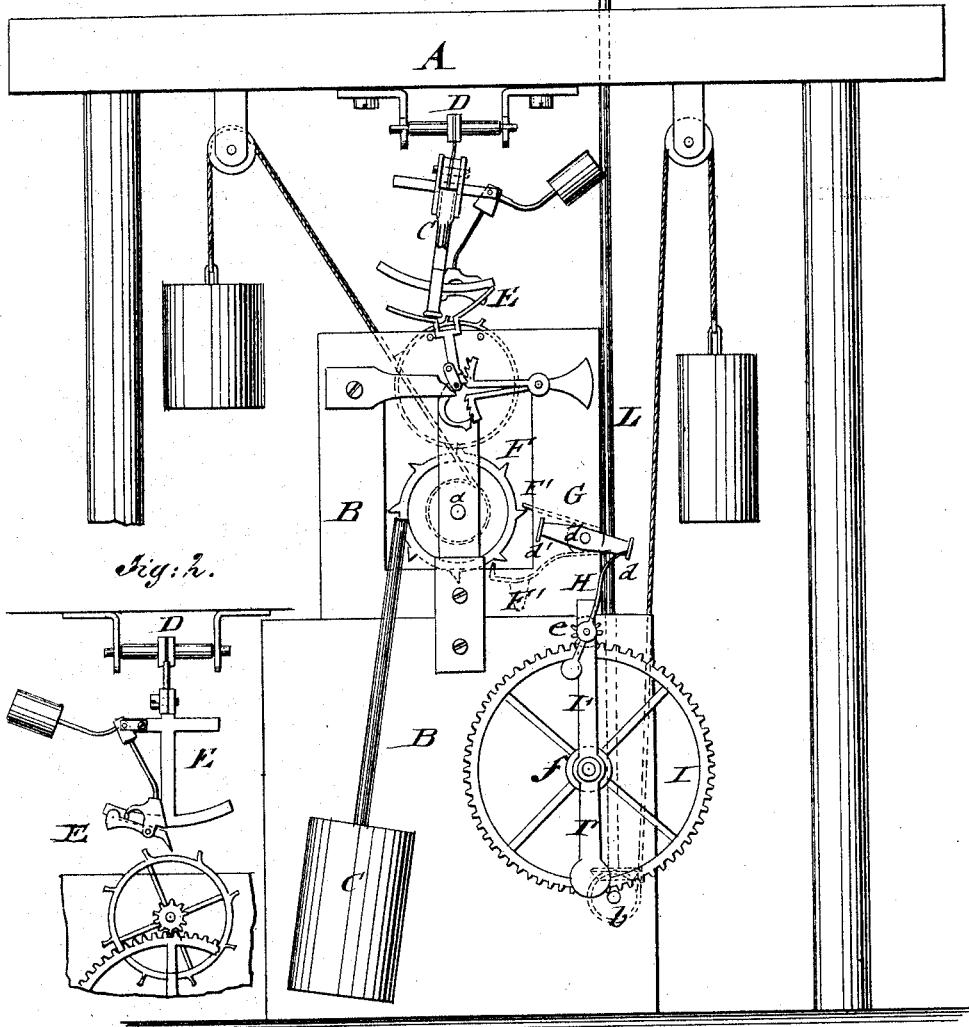
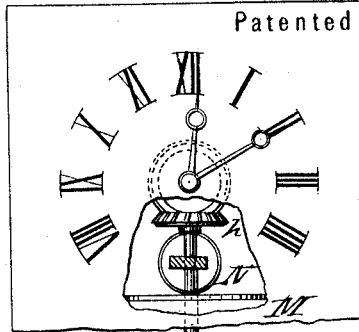

*Fig. 2.*

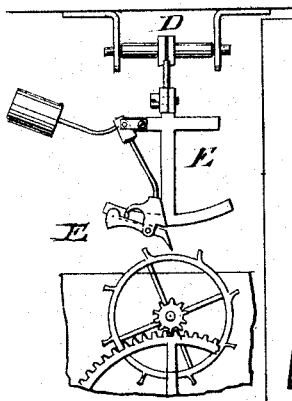

WITNESSES:

*Chas. Nida*  
*A. J. Terry*

INVENTOR:

*Chas. Fasoldt*

BY

*Munnell*  
ATTORNEYS.

C. FASOLDT.  
Tower Clock.

No. 165,991.

Fig. 3.

Patented July 27, 1875.

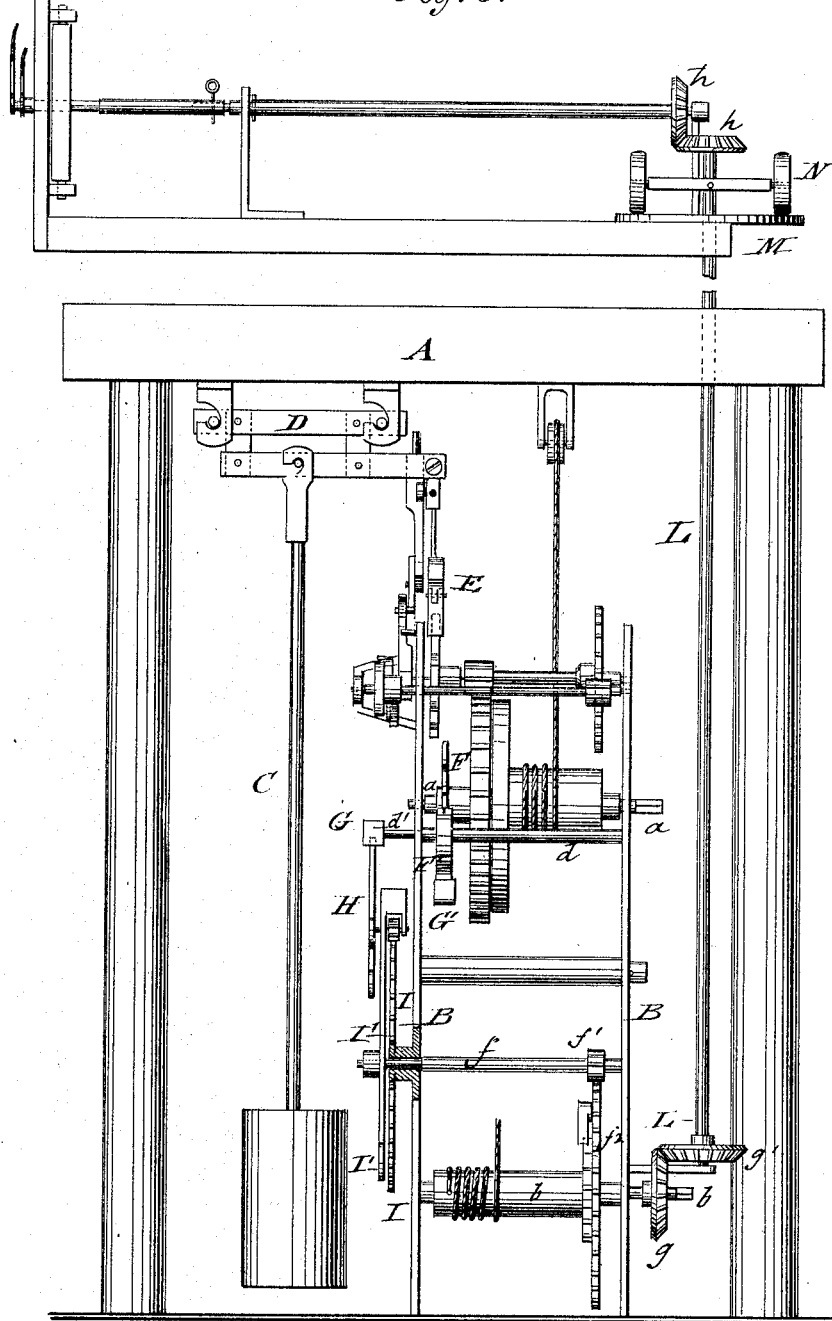

WITNESSES:

*Chas. Nide*  
*A. J. Terry*

INVENTOR:

*Chas. Fasoldt*  
BY *Munnell*  
ATTORNEYS.

# UNITED STATES PATENT OFFICE.

CHARLES FASOLDT, OF ALBANY, NEW YORK.

## IMPROVEMENT IN TOWER-CLOCKS.

Specification forming part of Letters Patent No. 165,991, dated July 27, 1875; application filed April 17, 1875.

*To all whom it may concern:*

Be it known that I, CHARLES FASOLDT, of Albany, in the county of Albany and State of New York, have invented a new and Improved Tower-Clock, of which the following is a specification:

In the accompanying drawing, Figure 1 represents a front elevation of my improved clock; Fig. 2, a detail view of the escapement, and Fig. 3 a side elevation of the same.

Similar letters of reference indicate corresponding parts.

The invention is mainly intended to so improve the construction of tower and other clocks that the driving mechanism of the hands is arranged separately from the clock-train, but so connected that the regular motion of the latter is not interrupted by any irregularities in the movements of the hands, either by the influences of the weather or other causes, and that the correct time may be indicated on any required number of dials without correspondingly enlarging the size and power of the clock mechanism. The continuous and uninterrupted working of the clock-train may thus be kept up independently of and without being interfered with by the hand-moving mechanism, which is run, however, in strict and accurate connection with the clock-train.

The invention consists mainly in the separation of the hand-moving mechanism and its actuating power from that of the clock-train, and its connection with an unlocking-wheel of the main arbor by an intermittently-operated planetary-motion device, actuated at certain intervals by the hand-driving weight, that transmits also motion to the hands on any suitable number of dials above or below the clock.

In the drawing, A represents the frame or supports, from which the actuating-weights are suspended by passing their cords over pulleys applied thereto.

Power is imparted to the clock-train and to the hand-driving mechanism by separate weights, of which the wire cord of the former is wound upon the cylinder of the main arbor *a* of the clock mechanism, while the cord of the latter is wound upon a cylinder of the mo-

tion-transmitting arbor *b* of the hand mechanism.

In place of the weights, springs or other equivalent motion-imparting devices may be employed. As regulating-escapement of the clock-train, I prefer that indicated by the letter E in the drawing, and for which Letters Patent have been granted to me under date of April 8, 1873, and No. 137,603; it being operated in connection with the pendulum C, that is oscillated on a spring suspension device, D. (Shown in Fig. 2.)

The working of the hand-driving mechanism is, however, not dependent on any special construction of the escapement or suspension of the pendulum, but may, with equal facility, be produced in reliable, but perhaps less accurate, manner by any approved clock construction.

The main arbor *a* of the clock-train is provided with an unlocking-wheel, F, that has a greater or smaller number of teeth, according as the forward motion of the minute-hand is intended to be performed at greater or smaller intervals of time—for instance, at every half or whole minute, or otherwise.

The teeth of the unlocking-wheel F engage a V-shaped fork, F', that is firmly applied to a separate arbor, *d*, of the clock-train, and raised by one tooth after the other as the wheel rotates, to be dropped when carried up till the contact of the tooth and the upper arm of the fork is discontinued.

To the outer end of the arbor *d* is attached an arm, G, with projecting rest or guard plates *d'* at one or both ends, that follow accurately the motion of the arbor *d*, by being alternately raised and dropped therewith.

The guards or rests *d'* of lever G serve to take up and release the end of a balanced spring-arm, H, that is keyed to the shaft of a small revolving pinion, *e*, which meshes with a toothed wheel, I, of larger but accurately-proportioned size, applied in fixed position to the clock-frame.

The shaft of pinion *e* is supported in bearings of a frame, L', that is keyed to the end of the arbor *f*, and accurately balanced by being weighted at the diametrically-extended arm of the same, so that the swinging of the

109,391

frame and the complete revolution of the pinion around the circumference of wheel I is accomplished in a perfect and easy manner. This motion of the pinion and balance-frame around the wheel I designate with the name of "planetary motion," which forms the intermediate locking and liberating mechanism of clock-train and hand-driving power.

The arbor  $f$  communicates by a pinion,  $f^1$ , with an intermeshing wheel,  $f^2$ , of the hand-actuating arbor  $b$ , which gears again by an outer bevel-wheel,  $g$ , with the bevel-wheel  $g'$  of the motion-transmitting shaft L.

The dials for indicating the time may be placed at any distance above or below the clock-train and hand-actuating mechanism, so that by the length of the shaft a considerable weight has to be overcome. This I accomplish by suspending the shaft from a carriage, N, that revolves on a platform, M, at the height of the dials above the clock. If the time has to be indicated on another set of dials below the clock, as is found very useful in many cases, either a separate shaft is suspended near arbor  $b$ , and operated thereby, or an extension of the same shaft, supported by another carriage and platform, has to be provided to facilitate the transmission of motion to the lower dial-hands. The lower conical end of the shaft L is supported in a corresponding bearing, in the usual manner. Bevel-wheels  $h$ , at the upper and lower ends of shaft L, transmit finally the motion to the minute-hand, and by the customary transmission to the hour-hand.

The greater the number of hands and dials employed for indicating the hour either at various heights or stories of a building, the greater in proportion has to be the actuating-weight, while the size of clock-train is not increased, so that the same may be constructed within a comparatively smaller compass, and be put up at any convenient part of a building or tower, forming thereby a considerable improvement over the large and heavy constructions of the present tower-clocks.

The gradual raising of the fork to the unlocking-wheel of the main arbor of the clock-train raises the outer lever G, on the guard-plate of which the spring-arm of the pinion rests, until, at a point near the highest limit of motion of lever G, the spring-arm is released and transferred to the guard-plate at the opposite lower end of lever G. The dropping of the fork to the next tooth at the moment of arriving at its highest point carries the lower guard-plate rapidly in upward direction, which motion liberates the spring-arm, and produces by the action of the separate hand-actuating weight instantly the complete planetary motion of pinion and spring-arm, until the latter is arrested again by the guard-plate of lever G, and thereby the action of the weight interrupted until liberated again, in the manner described.

Simultaneously with the accomplishing of the planetary motion of the pinion, the arbor of the hand-driving weight transmits motion to the suspended shaft and to the hands, so that the same are removed forward that distance on the dials, according to which the whole transmitting mechanism is constructed. Any interruption of the regular motion of the hands by ice or snow, or by the breaking or injuring of one of the intermediate parts, arrests the regular working of the hand mechanism, but without affecting in the least the clock-train, which continues its regular course without stopping, securing thereby to the clock a freedom from repairs and supervision, and a reliability and accuracy of working, that could not be obtained by the direct working of the dials from the clock-train in the usual manner. While I prefer two guard plates,  $d'$ , one may be used with similar effect.

The construction of the pendulum-suspending device D, Fig. 2, is such as to obviate the necessary use of a crotch, as applied in my patent aforesaid, thereby producing a simpler apparatus.

Having thus described my invention, I claim as new and desire to secure by Letters Patent—

1. In tower and other clocks, the clock-train and hand-driving mechanism, operated by separate actuating power, working independently of each other, substantially as and for the purpose set forth.
2. In tower and other clocks, the combination of an unlocking-wheel of the main arbor of the clock-train, controlled by swinging fork and guard-lever, with the planetary-motion device, actuated by the hand-driving arbor, substantially as shown and described.
3. The combination of the swinging lever, having projecting guard-rests, with the spring-arm of the planetary motion, so as to be arrested by the guard-plate at one end, and transferred to and liberated by the guard-plate at the other end, of the lever, substantially as set forth.
4. The planetary motion, for arresting and liberating the working of the separate hand-actuating weight, composed of larger fixed gear-wheel around hand-arbor, and of revolving frame, with circumferentially-traveling pinion and spring-arm, substantially as shown and specified.
5. The combination of hand-actuating arbor with one or more power-transmitting shafts, suspended by revolving carriage and platform to support weight of the same, in the manner and for the purpose substantially as described.

CHARLES FASOLDT.

Witnesses:

A. B. PRATT,  
R. DAYTON MONROE, M. D