

J. LACHLER.
Hasp-Lock.

No. 166,014.

Patented July 27, 1875.

Fig-1-

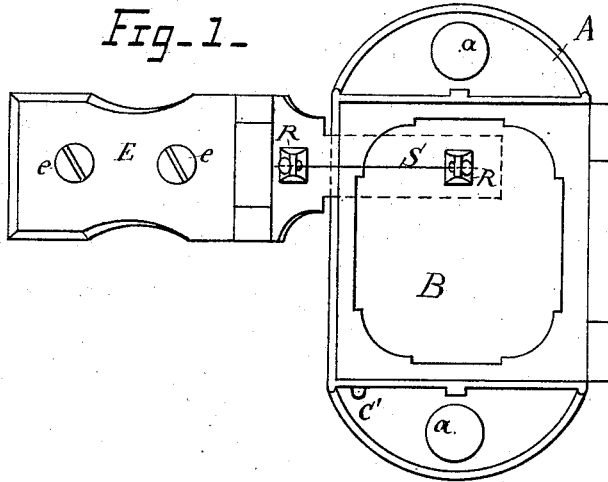
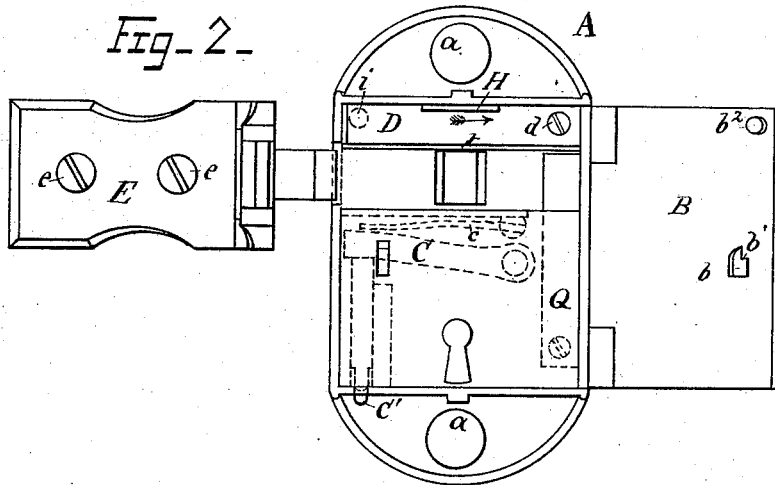

Fig-2-



WITNESSES

Otis C. Briggs.
W. Pfeiffer.

INVENTOR

Jochu Lachler

J. LACHLER. Hasp-Lock.

No. 166,014.

Patented July 27, 1875.

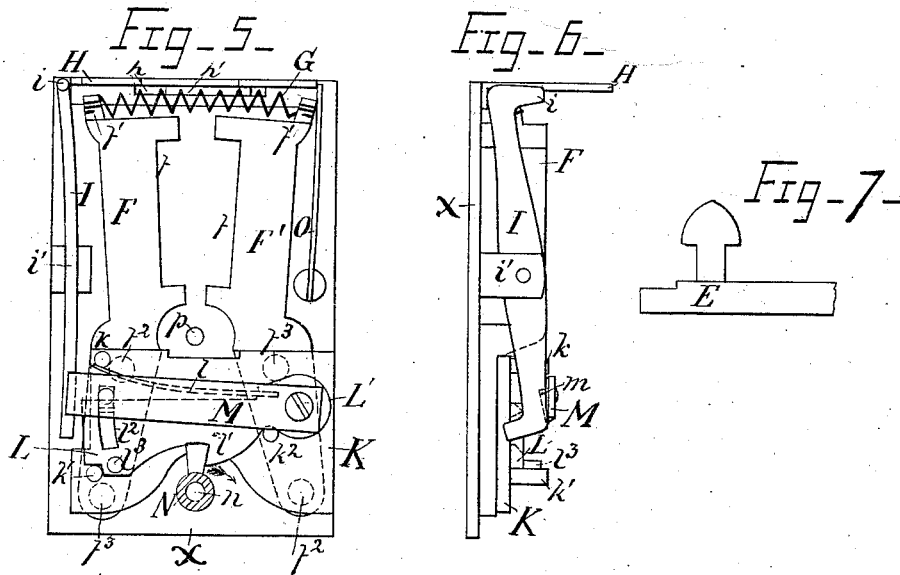
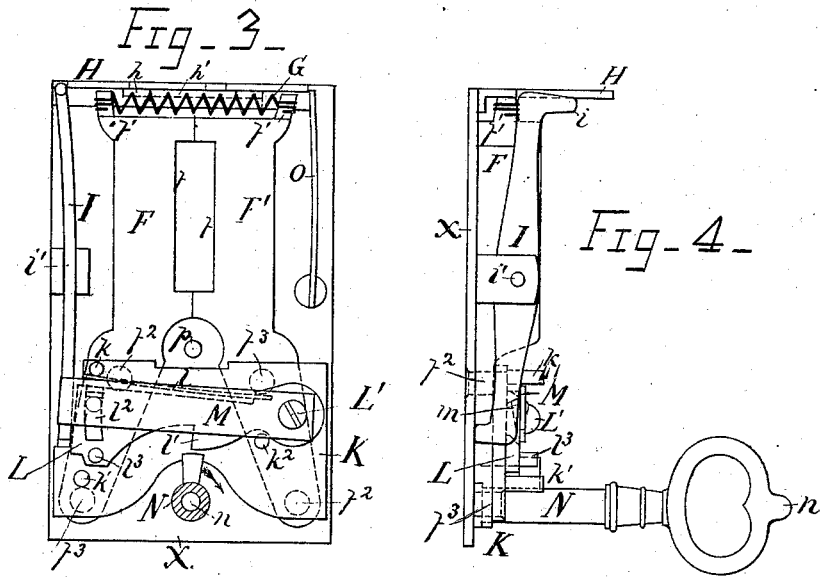

WITNESSES
Chas C. Briggs
W. Pfeiffer

INVENTOR
Joches Lachler

UNITED STATES PATENT OFFICE.

JOHN LACHLER, OF ERIE, PENNSYLVANIA.

IMPROVEMENT IN HASP-LOCKS.

Specification forming part of Letters Patent No. 166,014, dated July 27, 1875; application filed June 16, 1875.

To all whom it may concern:

Be it known that I, JOHN LACHLER, of the city of Erie, State of Pennsylvania, have invented a Door-Lock, of which the following is a specification:

The object of my invention is to provide doors, and more especially doors of freight-cars, with a lock at once simple, durable, and effective. To this end the invention is constructed as follows, reference being had to the accompanying drawings, in which—

Figure 1 represents the lock shut and sealed. Fig. 2 shows it open, with the lid B thrown back. Fig. 3 is a plan view of the locking parts arranged on plate *x*, with the bolts F and F' closed; and Fig. 4 is a side elevation of the same. Fig. 5 is a plan view of the same parts, showing the bolts F and F' open; and Fig. 6 is a side elevation of Fig. 5. Fig. 7 shows the shape of the catch on the end of hasp E, which may be made in any desirable and suitable shape to correspond with bolts F and F'.

The box A, Figs. 1 and 2, is shaped so as to receive the working parts of the lock, and is provided with holes *a* for the reception of bolts or screws, by which it is fastened to the door or casing, as may be desired. Hinged to this box A is a lid, B, for the purpose of protecting the working parts of the lock. This lid B is provided with a catch, *b*, which engages with a latch, C. This latch C is held down by the spring *c*, and is lifted up to release the catch *b* by means of the sliding bar C', in the usual manner. Attached to the lid B is also a lug, *b*², which depresses the spring D when the lid is shut. On the back plate *x*, which fits in the box A, are arranged the working parts. (Shown in Figs. 3, 4, 5, and 6.) The spring-bolts F and F' are each provided with holes *f*² and *f*³, two of which, *f*² *f*², correspond with and fit over pins attached to the plate *x*. They are also provided with a recess, *f*, of any desired shape, for the reception of the catch on the hasp. *f*¹ *f*¹ are lugs at the upper end of bolts F and F', to which is fastened a spiral spring, G, having the tendency of holding the bolts F and F' in the closed position shown in Fig. 3. The pin-holes *f*² *f*³ correspond with and receive pins projecting from the under side of the plate K, which plate is also provided with

pins *k*, *k*¹, and *k*² on its upper side. The lever L lies on plate K, and is pivoted to it by means of the screw or pin L', so that it can turn on plate K with the pin L' as fulcrum. To lever L is attached a spring, *l*, the pressure of which against the pin *k* forces the lever L down as far as the pins *k*¹ and *k*², or as far as the catch *m* on the under side of spring M and the corresponding slot *ℓ* in plate L will allow. This spring M is also fastened to plate K by the pin L'. The lever I has its fulcrum at *i*', and engages with springs M and D. The sliding stop-plate H is cut away on the side nearest the lever I, so that it can pass under it when said lever is in the position shown in Fig. 4, the spring O holding it (the stop-plate) in that position. The slot *h* in the bottom of stop-plate H corresponds with a tongue on plate *x*, only the slot *h* being long enough to allow for the sliding of plate H. N represents the key, which turns on the pin *n* attached to plate *x*, which plate, with all the parts arranged on it, is attached to the box A by means of the screw or pin *p*. The outer ends of the pins *k*, *k*¹, and *k*² touch the under side of a partition, on the outer face of which is arranged the fastening and opening devices for the lid B, explained above, and also a spring, Q, which projects into the recess for the hasp E, so that the said hasp depresses it when the lock is closed. Said pins *k*, *k*¹, and *k*² therefore prevent the plate K from becoming disengaged from the bolts. R R are lugs, one of which is fastened to the lock-box and the other to the hasp. They are provided with holes to receive a wire, S, the ends of which are sealed, as usual. The spring D is fastened to box A at *d*, and it is provided with a slot to let the upper part of the sliding stop-plate H pass through it in such a manner as to show no opening around it. *t* is a thin partition on the upper side of the recess for the hasp, for the purpose of preventing the end *i* of lever I being seen.

In opening the lock, the lid B is thrown open first by pushing with the pointed end *n'* of key N against the projecting end of sliding bar C', thereby pushing back the latch C. The action of the depressed spring D against the lug *b*² will then throw open the lid B. With the same end of key N the sliding stop-plate H is then moved in the direction indicated by the arrow

in Fig. 2 until it passes from under the lever I, and by holding it there, and at the same time pressing on the spring D, it will depress the end *i* of lever I, and the other end of lever I will be moved in the opposite direction, carrying with it the free end of spring M, thereby disengaging the catch *m* from the slot *l*². The pressure of the spring *l* against the pin *k* will then throw down the lever L until stopped by the pins *k*¹ and *k*². The bit of key N will then engage with the shoulder *l*¹ on lever L, as shown in Fig. 5. By turning the key N in the direction of the arrow, the lever L and with it, through the connecting-pin L', the plate K are moved in the same direction. The pins on the under side of plate K corresponding with the holes *f*³ *f*³ in bolts F and F', act upon said bolts, turning them on the pins attached to plate *x*, and corresponding with the holes *f*² *f*², thereby throwing apart said bolts, and disengaging the hasp E, which is then thrown back by the action of spring Q. By closing the hasp E, the lock will be locked, and by turning the key N in the opposite direction of the arrow, the lever L will be

pushed up, so that the catch *m* on spring M will enter the slot *l*², and hold the lever L in the position shown in Fig. 3, so that it is entirely out of contact with the key N. The action of the spring M brings back lever I in the position shown in Fig. 4. The moment the pressure on the end *i* of said lever I ceases the sliding stop-plate H, through the action of spring O, slides back to its first position, preventing the end *i* of lever I from being pressed in. The catch *m* is cut slightly tapered on the end which engages with the upper part of slot *l*², so that the pressure of spring M throws back the lever L far enough to entirely clear the bit of key N.

I claim as my invention—

The combination, in a door-lock, substantially as described, of bolts F and F', or their equivalent, plate K, lever L, spring M, lever I, stop-plate H, and spring O, and spring D.

JOHN LACHLER.

Witnesses:

OTIS C. BRIGGS,
WILLIAM REISSER.