

H. S. SHEPARDSON.

Locks.

No. 166,034.

Patented July 27, 1875.

Fig. 1.

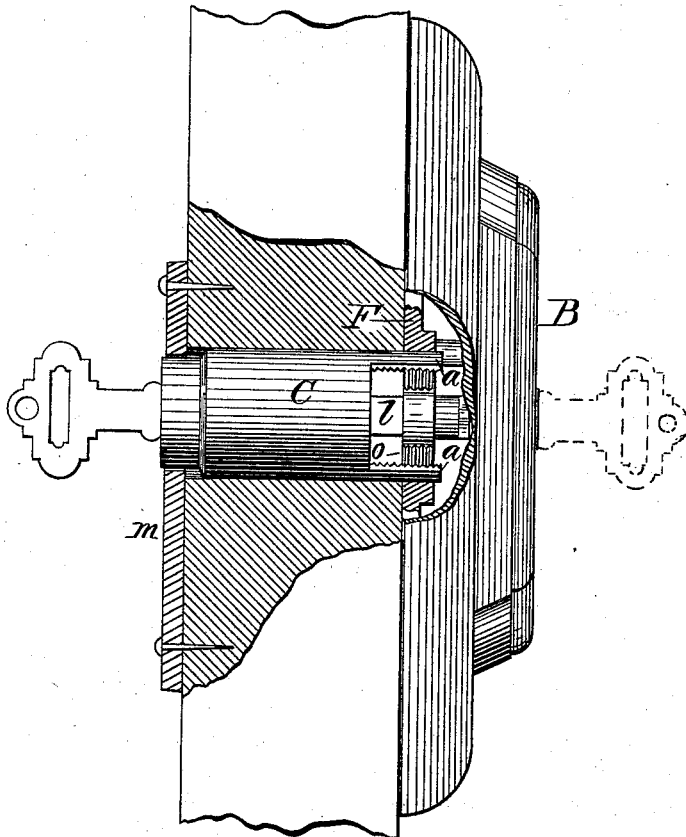

Fig. 2.

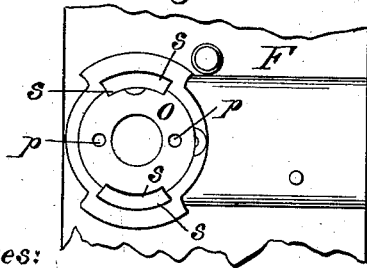
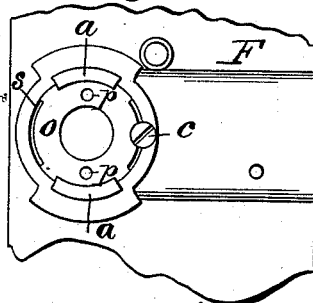

Fig. 3.



Witnesses:
Will H. Dodge
Donn Twitchell

Inventor:

H. S. Shepardson
by Dodge & Son
Athys

UNITED STATES PATENT OFFICE

HENRY S. SHEPARDSON, OF SHELBURNE FALLS, MASSACHUSETTS, ASSIGNOR
TO THE WINN LOCK COMPANY, OF SAME PLACE.

IMPROVEMENT IN LOCKS.

Specification forming part of Letters Patent No. **166,034**, dated July 27, 1875; application filed
April 1, 1875.

To all whom it may concern :

Be it known that I, HENRY S. SHEPARDSON, of Shelburne Falls, in the county of Franklin and State of Massachusetts, have invented certain Improvements in Locks, of which the following is a specification :

This invention relates to that class of locks which have a set of tumblers mounted in a cylinder projecting through the door; and my improvement consists in a novel manner of attaching said cylinder to the back plate or cover of the lock, as hereinafter more fully explained.

In the drawing, Fig. 1 represents an edge view of a door and lock having my improvement applied, a portion being broken away to show more clearly the location of the parts. Fig. 2 is a face view of a portion of the back plate or cover of the lock, the securing-nut being turned in the proper position to receive the legs of the cylinder, and Fig. 3 a similar view, showing the legs of the cylinder and the securing-nut locked in place.

In constructing and using my improved device, I provide the back plate or cover F with a circular opening having on its opposite sides recesses or notches *s*, and insert into said opening a threaded nut, *o*, as shown in Figs. 2 and 3, which nut is provided with notches *s*, corresponding to those in the circular opening of the back plate or cover. I next provide the cylinder C with legs *a*, which are provided on their inner faces with a screw-thread, as shown in Fig. 1. A hole is then bored through the door, of such diameter as to readily admit the cylinder C, the hole being so located as to cause the edge of the lock to fit flush with the edge of the door. The cylinder is then placed in the hole, the outer end of the same being made to come flush with or project slightly beyond the outer face of the escutcheon *m*, as shown in Fig. 1. The back plate or cover F of the lock is then placed in position, the legs *a* of the cylinder projecting through the openings formed by the notches *s* in the back

plate or cover F and the nut *o*. The back plate or cover F being placed close against the door, and the cylinder C being properly adjusted, the nut is given a half-turn, causing the threads on the same to engage with the threads on the inner face of the legs *a* of the cylinder C, thereby holding the cylinder in its proper position in relation to the back plate or cover F. In order to turn the nut *o* readily, I provide the same with holes *p*, into which may be inserted the ends of a bent wire or similar implement, thus providing a simple means of turning said nut. In order that the nut *o* may not be turned accidentally, after it is adjusted, I form a screw-hole in the edge of the nut and the opening in which the same is placed, and insert therein a screw, *c*, as shown in Fig. 3. Having thus arranged the parts, the ends of the legs *a* which protrude through the opening in the back plate or cover F, are cut off flush with said plate. The tumblers contained in the cylinder C are connected with those in the body of the lock B by means of a flat bar of metal, *l*, in the usual manner, thus allowing the lock to be operated from either side. The lock is next fastened in place by means of screws, the body B of the lock and the screws holding the back plate or cover in place, and this in turn holding the cylinder C.

It will be observed that this device forms a simple, cheap, and durable manner of securing the cylinder in place, and permits said cylinder to be adjusted to doors of any thickness.

Having thus described my invention, what I claim is—

The nut *o* and plate F, provided with the recesses or notches *s*, in combination with the cylinder C, provided with the legs *a*, said parts being provided with a screw-thread or grooves for adjusting and locking them together, substantially as described.

HENRY S. SHEPARDSON.

Witnesses :

FRANCIS R. PRATT,
TIMOTHY CRONAN.