

J. S. BEAZELL.

Harrow.

No. 166,061.

Patented July 27, 1875.

Fig. 1.

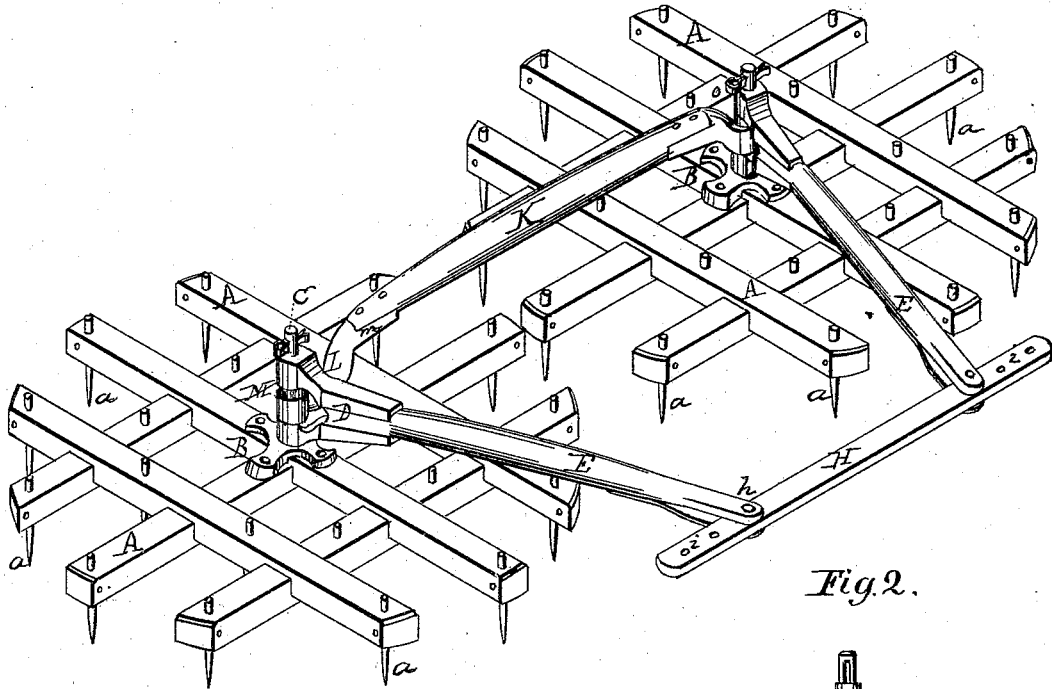

Fig. 2.

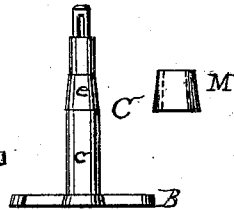

Fig. 3.

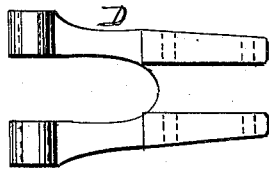
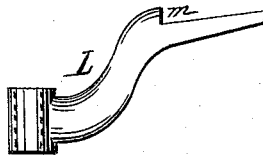

Fig. 4.



Witnesses:
Mr. Hendley
R. Gill

Inventor:
John S. Beazell
By his attys.
Cox and Cox

UNITED STATES PATENT OFFICE.

JOHN S. BEAZELL, OF CHILLICOTHE, MISSOURI.

IMPROVEMENT IN HARROWS.

Specification forming part of Letters Patent No. **166,061**, dated July 27, 1875; application filed February 1, 1875.

To all whom it may concern:

Be it known that I, JOHN S. BEAZELL, of Chillicothe, Missouri, have made and invented a new and useful Improvement in Harrows, of which the following is a specification:

My invention relates to improvements in harrows. It consists of two revolving harrow-frames, each having a post provided with a straight diameter, extending from its base to about the center of its length, and a tapering diameter for a short distance above the straight diameter, forming a seat for the washer M, in combination with a forked shoe having an upper and a lower eye, and a connecting-bar, provided with bearings having eyes corresponding with the straight diameter of the post, as will hereinafter more fully appear.

The posts are secured to the centers of the frames, and are tapered near their upper extremities, but not at their bases; and conformed to turn upon them are forked shoes, that are attached to the ends of draft-bars, a washer being provided to fit upon the upper portion of the tapered part of the post, to remove the friction of the coupling and drag bars from the foot-plate B, by sustaining the upper portion of the forked shoes D. The apertures in the forked shoes are of unequal size, adapted to the upper and lower parts of the post.

A coupling-bar, provided with a hand-piece, is arranged with a metallic bearing at each end, which is passed over the posts between the bearings of the forked shoe.

The draft-bars are connected at their forward extremities by a coupling-bar, which is so adjusted as to throw the lines of power between the two posts, thus compelling the frames to move outward.

In the accompanying drawings, Figure 1 is a perspective view of a device embodying the invention. Fig. 2 is a detached view of one of the posts; Fig. 3, a like view of one of the forked shoes, and Fig. 4 a similar view of one of the bearings upon the ends of the coupling-bar.

A are the frames, which are of any suitable form and construction, provided with the teeth *a*, which are preferably round. At their

centers are secured the metallic foot-plates B, to which the posts C are attached; or the posts and plate may be cast in one piece.

The construction of the posts C is clearly shown in Fig. 2. The lower part, *c*, is of the same diameter, and the upper part, *e*, tapered, so that the two parts conform, respectively, to the lower and upper bearings of the forked shoe D, the shape of which is fully disclosed in Fig. 3. E are the draft-bars, of appropriate length, to the rear ends of which are fastened the forked shoes D, their forward ends being connected by the coupling-bar H, which is adjusted by the pin *h* and apertures *i*. K is the rear coupling-bar, having a hand-piece, which is provided at both ends with the bearings L, having the rectangular shoulders *m*, the exact form of which appears in Fig. 4. The bearings L are conformed with relation to the posts C and the bearings of the forked shoes D, so that they may be inserted to occupy the position shown in Fig. 1, and secured by the pins *o*, the several parts being arranged to fully effect their objects, and at the same time permit a free rotation of the frames A. The metallic washers M fit upon the upper part of the tapered portion of the post *c*, and serve to sustain the forked shoes, so that the portion of the shoes, as well as the journal of the rear coupling-bar K, can revolve upon the post without any friction between their upper and lower surfaces, or with the foot-plate B, the entire horizontal friction being upon the upper surface of the washer M, the object being to afford play for the frames in passing over dangerous ground, to effect which the washers and bearings are arranged with the requisite intervals or spaces between them.

The connection of the ends of the draft-bars E with the coupling-bar H is such that they incline toward each other, whereby the frames are moved outward to left and right, thus freeing themselves at each revolution. To this end the length of the bar K is such that they will be held in suitable proximity to each other.

The operation of the device will be readily understood, and convenient means of practicing the invention will suggest themselves without further description of the details.

What I claim as my invention, and desire to secure by Letters Patent, is—

In a revolving harrow, the post C, constructed as shown, and provided with the washers M, in combination with the forked shoes D and bearings L, substantially as and for the uses and purposes set forth.

Witness my hand this 30th day of January,
A. D. 1875.

JOHN S. BEAZELL.

Witnesses:

CHARLES C. GILL,
JOS. T. K. PLANT.