

J. M. CAYCE.

Air-Supply Attachment for Carbureters.

No. 166,069.

Patented July 27, 1875.

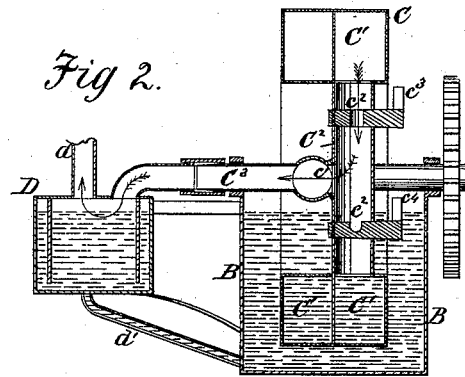
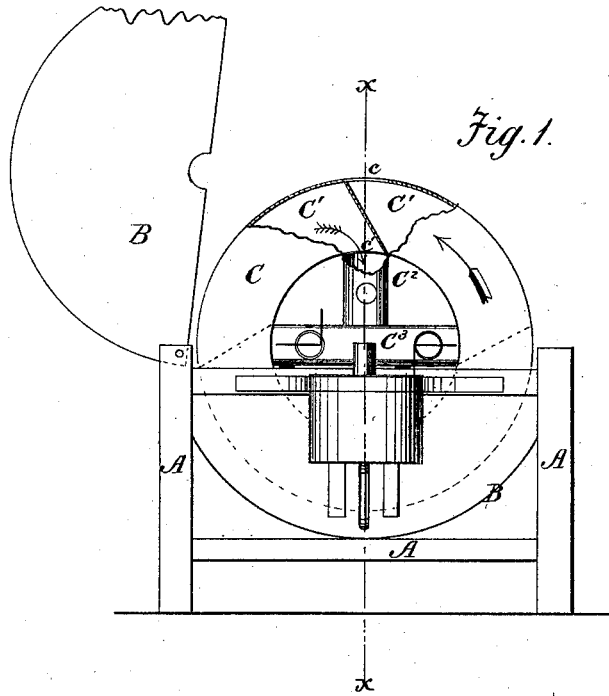

WITNESSES:

W. W. Hollingsworth
John Keman

INVENTOR:

John M. Cayce

BY

Kum & B

ATTORNEYS.

J. M. CAYCE.

Air-Supply Attachment for Carbureters.

No. 166,069.

Patented July 27, 1875.

Fig. 3.

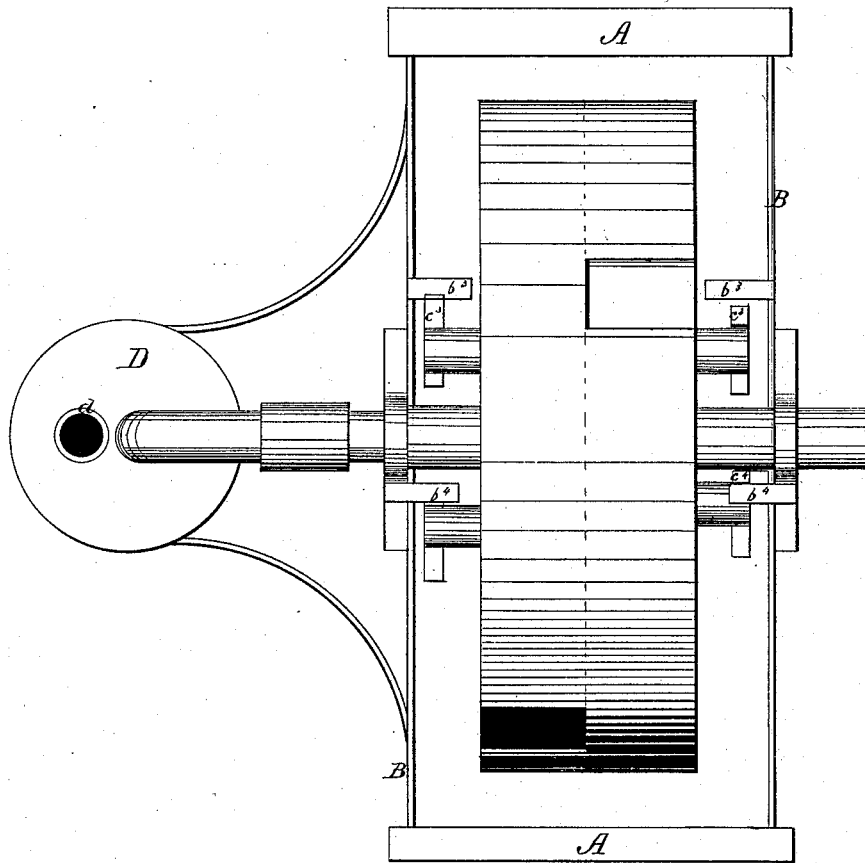

WITNESSES:

W. W. Hollingsworth
John Kemou

INVENTOR:

John M. Cayce
 BY *Wm & L*

ATTORNEYS.

UNITED STATES PATENT OFFICE.

JOHN M. CAYCE, OF FRANKLIN, TENNESSEE.

IMPROVEMENT IN AIR-SUPPLY ATTACHMENTS FOR CARBURETERS.

Specification forming part of Letters Patent No. **166,069**, dated July 27, 1875; application filed February 20, 1875.

To all whom it may concern:

Be it known that I, JOHN M. CAYCE, of Franklin, in the county of Williamson and State of Tennessee, have invented a new and Improved Air-Supply Attachment for Carbureters; and I do hereby declare that the following is a full, clear, and exact description of the same, reference being had to the accompanying drawing forming a part of this specification, in which—

Figure 1 is a longitudinal, and Fig. 2 a cross-sectional, elevation; Fig. 3, a plan view.

The invention relates to attachments for supplying carbureters with air, and will first be fully described in connection with the drawing, and then clearly pointed out in the claim.

A represents the frame, in which is supported a covered water-reservoir, B, in two parts, hinged together, and on the lower section of which is journaled a single or double wheel, C. The latter is made hollow and divided into two or more annular chambers, C¹, each having an inlet-port, *c*, upon its outer periphery, and an outlet-port, *c*¹, upon its inner periphery, opening into a pipe, C². The latter empties into a pipe, C³, that discharges into the air-reservoir D, that is connected by a pipe, *d*, with the carbureter. Each pipe C² has a double valve, *e*², provided with arms *e*⁴, that strike stationary trippers *b*³ *b*⁴ on the edge of the lower section of reservoir.

The mode of operation is as follows: Before an inlet-port, *c*, strikes the water, the chamber C¹ becomes filled with air; and after the inlet-port has become immersed in the water an arm, *e*², strikes a tripper, *b*³, thus opening the way for the passage of the air (that is now compressed by the water) into the pipe

C³, and thence into the air-reservoir D. The flow of air into the reservoir continues for one-half revolution of the wheel, when the arm *e*⁴ strikes tripper *b*⁴, closes the air-passage, and opens the way through valve to hole *e*⁵ in the pipe C², whence said water passes back into the reservoir B. If any water should be forced into the air-reservoir D with the air it will pass to the bottom thereof, and thence back through a pipe, *d*¹, to the water-reservoir; but as the power employed is a spring or weight, and can be accurately graduated, but little water will pass, while the shutting off of the gas from the burners will create a back pressure that quickly and automatically arrests the wheel. The supply of air to be passed through hydrocarbon to the burner (to manufacture the gas as it is burned) thus becomes perfectly uniform while the supply is begun and ended automatically by the weight or spring and the gas pressure.

Having thus described my invention, what I claim as new is—

1. The combination, with air and water reservoirs B D and pipe C³, of the hollow wheel C, having chambers C¹, and provided with inlet and outlet *c* *c*¹ and valved pipe *e*², operated as and for the purpose described.

2. The combination, with valves having arms *e*² *e*⁴, of the trippers *b*³ *b*⁴, as and for the purpose set forth.

3. The combination, with reservoirs B D, of the connecting-pipe *d*¹, as and for the purpose specified.

JOHN M. CAYCE.

Witnesses:

SOLON C. KEMON,
CHAS. A. PETTIT.