

T. HYATT.
Fire-Proof Safe.

No. 166,107.

Patented July 27, 1875.

Fig. 1.

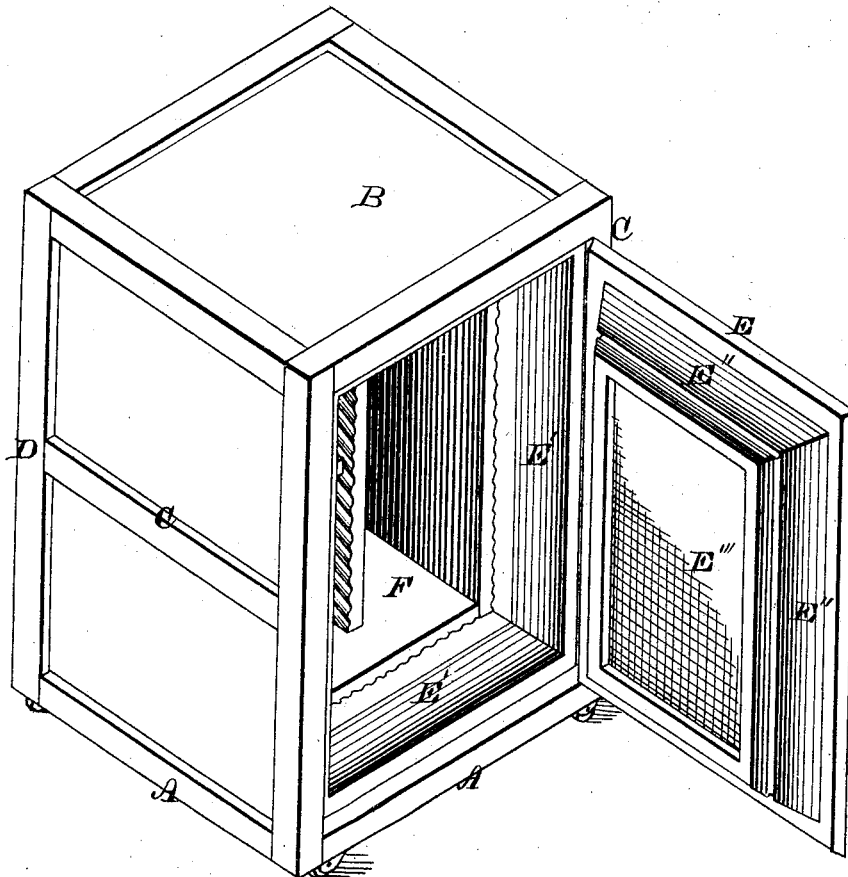

WITNESSES:
East. Hatchinson
John R. Young

INVENTOR
Theodore Hyatt, by
Orindle and Co. his Attys

T. HYATT.
Fire-Proof Safe.

No. 166,107.

Patented July 27, 1875.

Fig. 2.

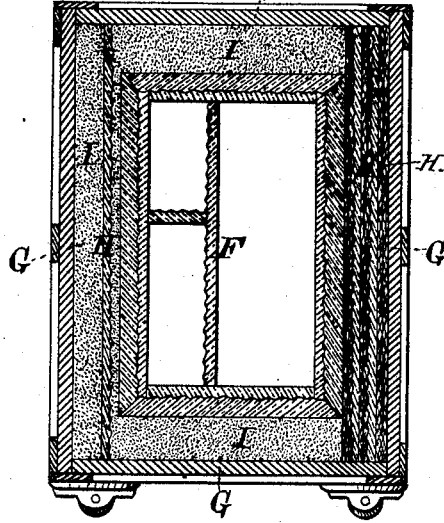

Fig. 4.

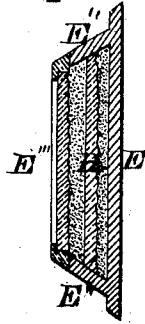

Fig. 5.

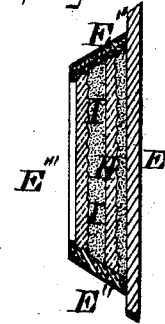
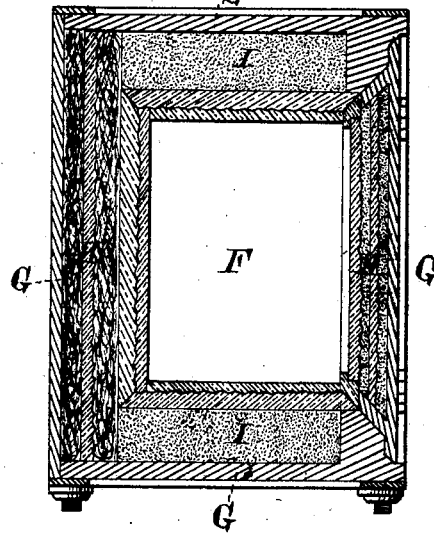

Fig. 3.



WITNESSES-

Gas. C. Hutchinson
John R. Young

INVENTOR-

Theodor Hyatt, by
Prindle & Lohie Attys

UNITED STATES PATENT OFFICE

THEODORE HYATT, OF NEW YORK, N. Y.

IMPROVEMENT IN FIRE-PROOF SAFES.

Specification forming part of Letters Patent No. **166,107**, dated July 27, 1875; application filed July 3, 1875.

To all whom it may concern:

Be it known that I, THEODORE HYATT, of New York city, in the county of New York and in the State of New York, have invented certain new and useful Improvements in Safes; and do hereby declare that the following is a full, clear, and exact description thereof, reference being had to the accompanying drawings, making a part of this specification, in which—

Figure 1 is a perspective view of a safe constructed in accordance with my improved method. Fig. 2 is a vertical central section of the same upon a line parallel with the front. Fig. 3 is a like view upon a line extending from front to rear; and Figs. 4 and 5 are horizontal sections of the door, showing different ways of constructing the same.

Letters of like name and kind refer to like parts in each of the figures.

In the manufacture of safes great difficulty has been experienced in rendering their interiors proof against external heat, and in every instance in which this result has been accomplished it has been necessary that the walls of the safe should be filled with water, either in its natural state or in the form of chemical salts, which hold the same in a crystalline form; but while these agents have proved efficient in preserving the contents of a safe from injury by fire, they have been a source of great injury to books and papers, in consequence of the steam thrown off during a fire and of dampness generated at other times.

To remedy these objections is the design of my invention, which consists, principally, in a fire-proof safe in which the hollow walls contain a filling of glass, the molecular structure of which has been changed so as to render it tough and a non-conductor of heat, substantially as and for the purpose hereinafter specified. It consists, further, in combining, with said glass filling, asbestos or other heat non-conducting earths or minerals, substantially as and for the purpose hereinafter shown. It consists, further, in combining with said glass, non-conducting earths and minerals, and chemical salts containing water of crystallization, substantially as and for the purpose hereinafter set forth. It consists, further, in a fire-proof safe in which the book-case, partitions,

and shelves are constructed of or from said glass, substantially as and for the purpose hereinafter shown and described. It consists, finally, in a fire-proof safe in which the jambs of the door and its frame are composed wholly or in part of said glass, substantially as and for the purpose hereinafter specified.

In the annexed drawings, A represents the bottom, B the top, C and C the sides, D the back, and E the door, of a safe constructed of iron in the usual manner. Within the shell of the safe is placed a book-case, F, each portion of which is constructed of toughened glass, and between the contiguous portions of the same and of said case is left a space, G, of the usual form, for the reception of the heat non-conducting filling. Within the space G at each side of the book-case F is placed a sheet, H, of toughened glass, which has substantially the same area as the former, and is placed midway between the walls of said inner and outer case, after which the remainder of said space, upon each side of said glass, is filled with some suitable earths, chemical salts, or minerals I, which are non-conductors of heat, for the purpose of insuring the position of said glass and preventing displacement in case of breakage.

If desired, the entire space between the inner and outer walls of the safe may be filled with glass; but I prefer to place the glass as stated, and upon each side place, in either a plastic or dry state, Glauber's salts, gypsum, asbestos, or earthy matters, which articles may be applied singly in combination with each other, or combined with any suitable ingredient which is a partial or perfect non-conductor of heat. Again, if desired, two or more sheets of glass, separated by the loose filling, may be placed within each space, but it is thought that but one will be required.

The jambs E' and E'' of the door frame and door, respectively, are usually the means whereby heat is most readily conducted from the exterior to the interior of a safe; but in my safe they are constructed wholly or in part from the toughened glass, and thereby the result named is avoided. The inner face E''' of the door E is, also, composed of glass, and when closed forms a front to the book-case F, so that between the contents of the latter and the ex-

terior of the safe, two, at least, sheets of the heat non-conducting glass are interposed.

In consequence of the great power of the toughened glass to resist the passage of heat, a less thickness than usual is required for the walls of a safe, and consequently a greater interior capacity is secured and the dead weight of the safe correspondingly lessened.

If only the glass and asbestos, Portland cement, or other similar articles are employed for filling the walls of the safe, all possibility of dampness will be avoided, and the interior rendered as dry as would be the interior of a wooden box.

Having thus fully set forth the nature and merits of my invention, what I claim as new is—

1. A fire-proof safe in which the hollow walls contain a filling of glass, the molecular structure of which has been changed so as to render it tough and a non-conductor of heat, substantially as and for the purpose specified.

2. In combination with a filling of toughened glass for the walls of a safe, asbestos, or other

heat non-conducting minerals or earths, substantially as and for the purpose shown.

3. In combination with a filling of toughened glass for the walls of a safe, heat non-conducting earths or minerals and chemical salts containing water of crystallization, substantially as and for the purpose set forth.

4. A fire-proof safe in which the book-case, partitions, and shelves are constructed of or from toughened glass, substantially as and for the purpose shown and described.

5. A fire-proof safe in which the jambs of the door frame and door and inner face of same are composed wholly or in part of toughened glass, substantially as and for the purpose specified.

In testimony that I claim the foregoing I have hereunto set my hand this 30th day of June, 1875.

THEODORE HYATT.

Witnesses:

E. P. STARR,

WILLIAM ACKERMANN.