

C. M. LUFKIN & C. G. ALLEN.
Horse Hay-Rake.

No. 166,118.

Patented July 27, 1875.

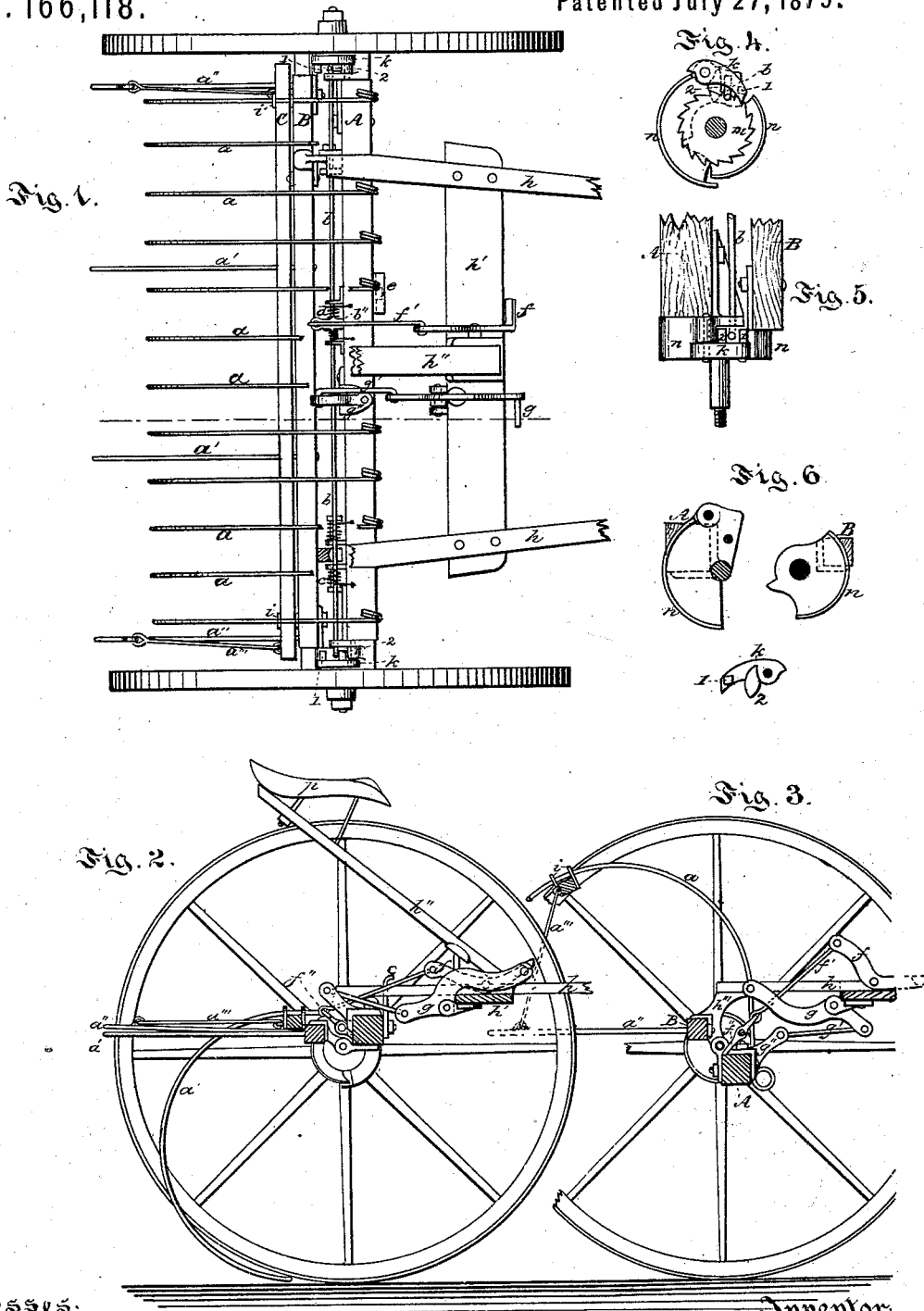

Witnesses:

B. Edmunds,
G. B. Payne.

Inventor:

Charles M. Lufkin,
Charles G. Allen,
By B. T. Lantz,
att'y.

UNITED STATES PATENT OFFICE.

CHARLES M. LUFKIN AND CHARLES G. ALLEN, OF BARRE, MASSACHUSETTS.

IMPROVEMENT IN HORSE HAY-RAKES.

Specification forming part of Letters Patent No. **166,118**, dated July 27, 1875; application filed January 22, 1875.

To all whom it may concern :

Be it known that we, CHARLES M. LUFKIN and CHARLES G. ALLEN, of the town of Barre, county of Worcester and State of Massachusetts, have invented new and useful Improvements in Horse Hay-Rakes; and we do hereby declare the following to be a true and correct description of the construction and operation of the same, reference being had to the accompanying drawings making part and parcel of this our specification.

The nature of our invention consists in the construction and attachment to the inner ends of the wheel-hubs, of a ratchet, each ratchet having a pawl engaging with the same, which is secured to the axle, such pawl being operated by means of a rod running parallel with and secured to such axle, and operated by means of treadles, levers, and springs, and the action of the same controlled by the feet of the driver while upon his seat, or by the hand of the driver by prolonging the arms of such levers, &c., in the manner hereinafter described and pointed out in the claims, the construction, operation, and combined action of such pawl, ratchet, levers, and treadles being intended to accomplish the result of discharging, at the proper time, the hay or other analogous material contained within and by the teeth of the rake. Also in the construction and arrangement of the hay stripper-bar, and its connection with the outer teeth at each end of the rake, and the stripper rods or arms also connected to such stripper-bar, and to a cross-bar, to the latter of which the shafts are attached, as well as to the axle.

In order to enable others skilled in the art to make and use this invention, we will describe the construction and operation of the same.

In the drawings, Figure 1 is a top or plan view of the machine. Figs. 2 and 3 are side views in cross-section, showing the position of the rake in two positions, with the arrangement of levers, treadles, and strippers. Fig. 4 shows the position of the pawl, engaged with ratchet, with the projections or lugs formed upon such pawl, and their relation to the vent-arms upon the longitudinal rod in cross-section. Fig. 5 shows a top and plan view of same. Fig. 6 shows the shield surrounding the ratchet and the pawl, with

the projections on the pawl, which is attached to the larger shield.

In the drawings, A represents the axle, as well as the rake-head, to which the teeth *a a* are secured, such teeth being bent in the form of a half circle, or nearly so. B is a cross-bar, to which are attached, at right angles, the hay-strippers *a a* and *a' a'*. The shafts of the hay-rake *h* are pivoted to the axle or head A by means of the bent arms *h'''*, and by means of such arms connect the cross-bar B and axle A together, as seen in Fig. 3. The teeth, secured to the axle, can be raised or lowered by turning the axle or pressing the same downward by means of the arm or foot-piece *e* at the left of the driver's seat, who can operate the same and control the movement of said teeth, when desired, by raising such teeth when passing over stubble or uneven surfaces, or other obstacles. This device just described is arranged to co-operate with the lever *g*, rod *g'*, and arm *g''*, the latter secured to the axle A. By pressing down with the foot-lever *g*, the teeth are held in contact with the hay upon the ground, and the motion of the teeth over uneven ground or obstacles controlled in a similar manner as when they are operated by the arm or foot-piece *e*. The stripper-bar C is secured in position on the under side of the teeth, by being connected to the end teeth by means of a staple or clevis, *i*, said end teeth passing through eyes (formed within such staple or clevis) upon the upper side of such stripper-bar C. The two outer stripper-rods *a''*, in addition to being secured to the cross-bar B are also secured to the stripper-bar by means of the connecting-rods *a'''*, so that when the teeth are raised, or are being raised, the rods *a' a'* and *a'' a''* force the hay from the teeth, and are in the position seen in Fig. 3, partly in dotted lines. Another mechanism is also used to perform this operation of releasing the hay from the teeth by means of the motion of the wheels. To the inner portion of the hubs of such wheels are secured ratchets *m*, with which the pawls *k* engage. The latter are pivoted to the larger shield *n*, and are raised out of or forced into contact with the ratchets by means of the bent arms upon the end of the rod *b*. While the rake is in motion the pawls *k* rest upon

the said bent arms and disconnected from the ratchets *m*, the lugs 1 formed upon such pawls then being upon the ends of the bent arms of the rod *b*. A cam shaped projection, 2, is also formed upon said pawl, so that when the arm or support is removed from the lug 1 the arm presses upon and downward the cam 2, forcing the pawl in contact with the ratchet *m*. The connection of the shield *n*, to which the pawls are attached, to the axle causes such axle to rotate, thereby raising the teeth of the rake, when the pawls and ratchets are in contact with each other. To control the operation of the rod *b* I employ the foot-treadle or lever *f*, rod *f'*, and arm *f''*, the latter securely fastened to the rod *b*, and within the control of the driver upon his seat *p*. A spring, *d*, connects with the rod *b* and arm *f''*, which, upon removal of the foot of the driver from the lever *f*, causes the arms on the end of the rod *b* to resume their support of the pawl, as before mentioned. To aid in the return of the rake to its proper position after the hay is released, I attach a spring, *c*, to a rod that secures the right-hand shaft to the axle *A*, so that when the axle is turned downward the spring is wound up by means of its connection with the axle and rod, and upon the withdrawal of the foot from the lever *g* the spring *c* causes the axle to return to its normal position. The levers *f* and *g* are secured to

the foot-board *h'*, and the seat *p*, and brace *h''* also secured to the foot-board *h'*, as seen in Figs. 1 and 2. The stripper-bar *C* slides freely upon the end teeth of the rake, and acting also as a support to the teeth *a a a*, as well as aiding in the discharge of the hay from the rake.

What we claim as our invention, and desire to secure by Letters Patent, is—

1. The combination of the lever *f*, rod *f'* with the rod *b*, and pawl *k* with its lugs 1 and 2, and ratchet *m*, when constructed and arranged to operate in the manner and for the purpose herein described.

2. The stripper-bar *C*, in combination with the end teeth *a a*, stripper-rods *a''*, and connecting-rods *a'''*, in the manner and for the purpose herein described.

3. The combination of the stripper-rods *a''* with the connecting-rod *a'''* and stripper-bar *C*, and cross-bar *B*, in the manner and for the purpose herein set forth.

In testimony whereof we have signed our names in the presence of two subscribing witnesses.

CHAS. M. LUFKIN,
CHAS. G. ALLEN.

Witnesses:

A. M. BURT,
HENRY M. SHATTUCK.